

# BC installation component housing

## Installation component housing of the BC series



Data sheet  
102981\_en\_07

© PHOENIX CONTACT 2020-08-19

### 1 Description

The installation component housings of the **BC** series are suitable for use in common installation distributor boxes and comply with the standard DIN 43880.

The component housings are available in five different **design widths**, from the width of one horizontal pitch (1TE = 17.8 mm) up to nine horizontal pitches (9TE = 161.6 mm).

Starting with the design width 2TE (35.6 mm), the installation space for PCB connection technology is available in two different installation depths:

- The connection technology for BC...U11 has 11 mm of space. This is ideal for the use of connection technology with small pitch dimensions (e.g. COMBICON compact)
- The installation space for connection technology with BC...U22 has been maximized to 22 mm of space. For instance, double-level connection terminal blocks or RJ45 connectors can be mounted.

Figure 1 Overview

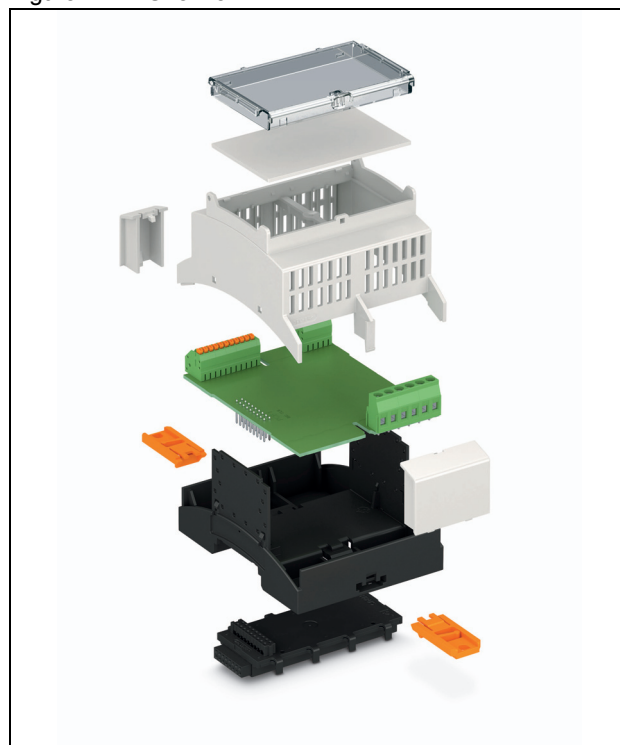

**WARNING:** Only electrically qualified personnel may install and operate the housing. The qualified personnel must be able to recognize and prevent danger.

**i** The 3D housing data can be found at [phoenixcontact.net/products](https://phoenixcontact.net/products).

**i** Make sure you always use the latest documentation. It can be downloaded at [phoenixcontact.net/products](https://phoenixcontact.net/products).

**i** This document is valid for all products listed in the “Ordering data” on page 4.

**Table of contents**

1 Description ..... 1

2 Overview of BC Products ..... 2

3 Ordering data ..... 4

    3.1 Ordering data (1TE to 9TE) ..... 4

    3.2 Order key for BC 161,6 modular – upper part ..... 7

    3.3 Selecting the right connection technology ..... 8

4 Technical data ..... 9

5 Safety notes ..... 9

6 Housing dimensions ..... 10

    6.1 Dimensions of housing ..... 10

    6.2 Dimensions of DIN rail connector ..... 11

7 PCB arrangement for BC 17,8 (1TE) ..... 12

    7.1 PCB dimensions ..... 12

    7.2 Inner dimensions ..... 14

    7.3 Circuit diagram of DIN rail connector with 2 and 3 slots ..... 15

    7.4 Dimensional drawing of connector for DIN rail connector ..... 15

    7.5 Safety notes ..... 15

    7.6 Derating ..... 15

8 PCB arrangement for BC 2TE – 9TE ..... 16

    8.1 Plug-in positions for horizontal PCBs ..... 16

    8.2 Circuit board dimensions for PCB 1, horizontal ..... 17

    8.3 Circuit board dimensions for PCB 2 to 8, horizontal ..... 25

    8.4 Circuit board dimensions for PCB 9, horizontal ..... 26

    8.5 Perpendicular PCBs – transverse to the DIN rail ..... 30

    8.6 Perpendicular PCBs – parallel to the DIN rail ..... 31

9 PCB arrangement for BC 161,6 modular ..... 32

    9.1 Plug-in positions for horizontal PCBs ..... 32

    9.2 Versions for the terminal installation space ..... 33

    9.3 Circuit board dimensions for PCB 1, horizontal ..... 34

    9.4 Circuit board dimensions for PCB 2 to 8, horizontal ..... 36

    9.5 Circuit board dimensions for PCB 9, horizontal ..... 40

    9.6 Perpendicular PCBs (BC 161,6 modular) ..... 41

10 DIN rail connector with 1 slot (2TE – 9TE) ..... 45

    10.1 Circuit diagram of DIN rail connector ..... 45

10.2 Dimensional drawing of connector for DIN rail connector ..... 45

10.3 Safety notes ..... 45

10.4 Derating ..... 45

**2 Overview of BC Products**

Figure 2 Overview

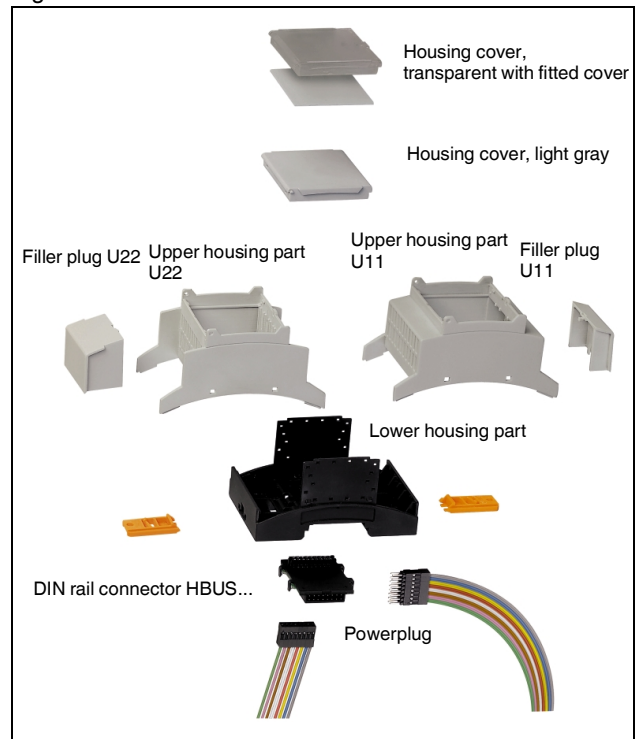
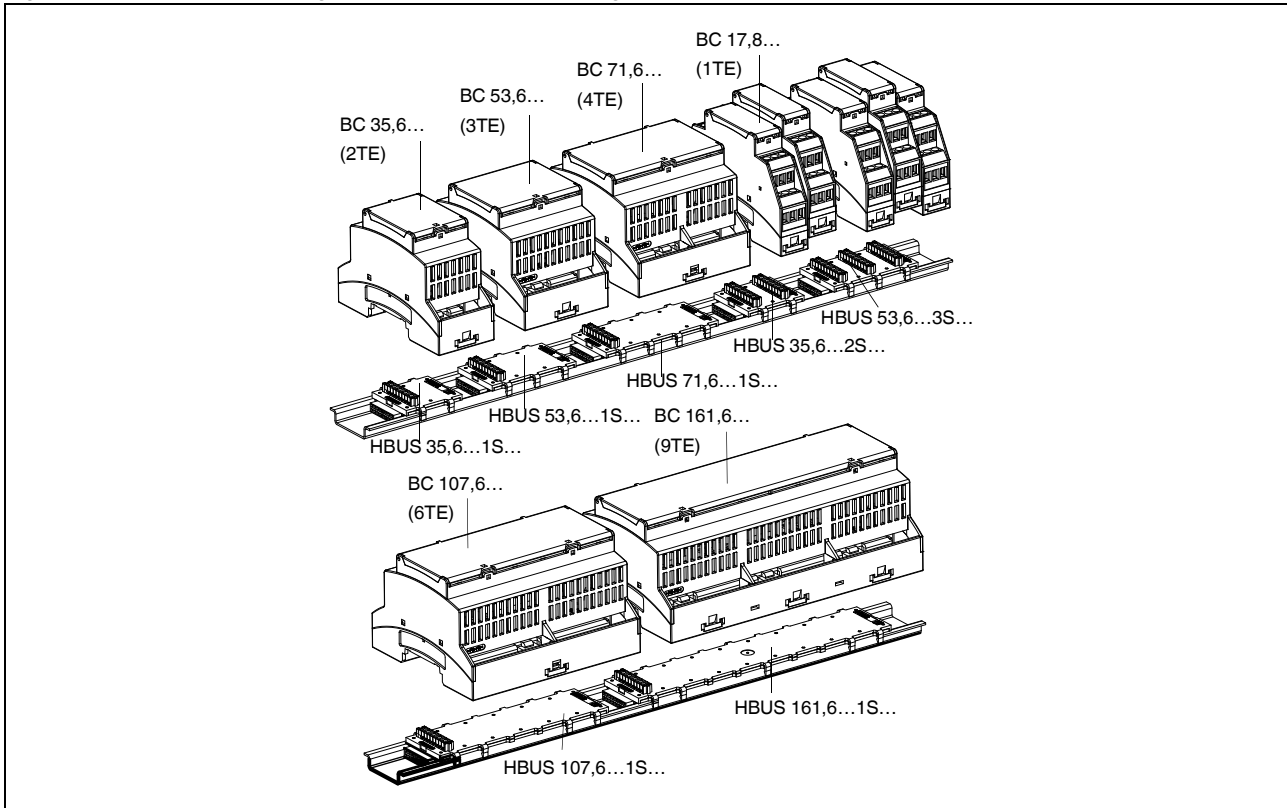

Figure 3 Overview of design widths with corresponding DIN rail connector HBUS



With **BC 161,6 modular**, the side panels in each of the six segments on each side of the housing can be arranged in three different positions. When the side panel is located at the innermost position, the installation space for connection technology is maximized to 22 mm. The installation space for connection technology is 11 mm for the middle side panel position. When the side panel is located at the outermost position, the installation space for connection technology is closed off.

The **PCBs** can be installed parallel or perpendicular to the DIN rail starting at 2TE. The perpendicular PCBs can, however, be aligned either parallel or transverse to the DIN rail. In all cases the PCBs can be snapped in at different locations.

The **cover** is available in two versions:

- Transparent, hinged and can be sealed
- In the same light gray color as the housing, permanently snapped onto the upper housing part

The component housings are mounted on an NS 35 DIN rail. Optionally, a 16-pos. **DIN rail connector** can be inserted in the DIN rail. This serves to establish automatic contact from device to device. With the bus connector, data and energy transmission can be serial or parallel (4 x power, 2 x serial, 10 x parallel). Individual devices can be plugged in or unplugged without breaking up the group of modules.

### 3 Ordering data

#### 3.1 Ordering data (1TE to 9TE)

##### Design width 17.8 mm (1TE)

Description	Type	Order No.	Pcs. / Pkt.
<b>Lower housing part</b>	BC 17,8 UT HBUS BK	2896241	10
<b>Upper housing part</b> , for horizontal PCB connection with 3.5 mm or 5 mm pitch	BC 17,8 OTU MKDSO KMGY	2279732	10
<b>Housing cover</b> , permanently snapped onto the upper housing part, in the same light gray color as the housing	BC 17,8 DKL R KMGY	2896144	10
<b>Housing cover</b> , hinged, can be sealed, transparent, including fitted cover	BC 17,8 DKL S TRANS	2896102	10

##### Accessories

<b>PCB terminal block</b> , for soldering onto PCB, 3.5 mm pitch, number of positions: 4	Left	MKDSO 1,5/ 4-L-3,5 KMGY	2278432	50
	Right	MKDSO 1,5/ 4-R-3,5 KMGY	2278429	50
<b>PCB terminal block</b> , for soldering onto PCB, 5 mm pitch, number of positions: 3	Left	MKDSO 2,5/3-L KMGY	2854102	50
	Right	MKDSO 2,5/3-R KMGY	2854092	50
<b>DIN rail connector</b> , 16-pos., 18-pos. slots to the PCB	2 Slots	HBUS 35,6-16P-2S BK	2896319	10
	3 Slots	HBUS 53,6-16P-3S BK	2896322	10
<b>Power plug</b> for DIN rail connector, with 16 free cable ends with a cross section of 0.25 mm <sup>2</sup> , 500 mm long	Socket strip	BL2-2,54/16-ST	2896335	50
	Pin strip	SL2-2,54/16-ST	2896348	50
<b>Cover cap set</b> , 3-piece, for protecting empty DIN rail connectors		HBUS-B SET BK	2278173	10
<b>Filler plug</b> for empty terminal space		ME 17,5 OTU-MKDSO KMGY	2854115	50

##### Design width 35.6 mm (2TE)

Description	Type	Order No.	Pcs. / Pkt.
<b>Lower housing part</b>	BC 35,6 UT HBUS BK	2896254	10
<b>Upper housing part</b> , with vents, terminal installation depth 11.1 mm	BC 35,6 OT U11 KMGY	2896034	10
<b>Upper housing part</b> , with vents, terminal installation depth 22.35 mm	BC 35,6 OT U22 KMGY	2896047	10
<b>Housing cover</b> , permanently snapped onto the upper housing part, in the same light gray color as the housing	BC 35,6 DKL R KMGY	2896157	10
<b>Housing cover</b> , hinged, can be sealed, transparent, including fitted cover	BC 35,6 DKL S TRANS	2896115	10

##### Accessories

<b>DIN rail connector</b> , 16-pos., 18-pos. slot to the PCB	1 Slot	HBUS 35,6-16P-1S BK	2896283	10
<b>Power plug</b> for DIN rail connector, with 16 free cable ends with a cross section of 0.25 mm <sup>2</sup> , 500 mm long	Socket strip	BL2-2,54/16-ST	2896335	50
	Pin strip	SL2-2,54/16-ST	2896348	50
<b>Cover cap set</b> , 3-piece, for protecting empty DIN rail connectors		HBUS-B SET BK	2278173	10
<b>Filler plug</b> for empty terminal space, 17.6 mm design width, for terminal installation depth	11 mm	BC 17,6 BS U11 KMGY	2896186	50
	22 mm	BC 17,6 BS U22 KMGY	2896199	50
<b>Filler plug</b> for empty terminal space, 35.6 mm design width, for terminal installation depth	11 mm	BC 35,6 BS U11 KMGY	2896209	50
	22 mm	BC 35,6 BS U22 KMGY	2896212	50

**Design width 53.6 mm (3TE)**

Description	Type	Order No.	Pcs. / Pkt.
<b>Lower housing part</b>	BC 53,6 UT HBUS BK	2896403	10
<b>Upper housing part</b> , with vents, terminal installation depth 11.1 mm	BC 53,6 OT U11 KMGY	2896416	10
<b>Upper housing part</b> , with vents, terminal installation depth 22.35 mm	BC 53,6 OT U22 KMGY	2896429	10
<b>Housing cover</b> , permanently snapped onto the upper housing part, in the same light gray color as the housing	BC 53,6 DKL R KMGY	2896432	10
<b>Housing cover</b> , hinged, can be sealed, transparent, including fitted cover	BC 53,6 DKL S TRANS	2896445	10

**Accessories**

<b>DIN rail connector</b> , 16-pos., 18-pos. slot to the PCB	1 Slot	HBUS 53,6-16P-1S BK	2896458	10
<b>Power plug</b> for DIN rail connector, with 16 free cable ends with a cross section of 0.25 mm <sup>2</sup> , 500 mm long	Socket strip	BL2-2,54/16-ST	2896335	50
	Pin strip	SL2-2,54/16-ST	2896348	50
<b>Cover cap set</b> , 3-piece, for protecting empty DIN rail connectors		HBUS-B SET BK	2278173	10
<b>Filler plug</b> for empty terminal space, 17.6 mm design width, for terminal installation depth	11 mm	BC 17,6 BS U11 KMGY	2896186	50
	22 mm	BC 17,6 BS U22 KMGY	2896199	50
<b>Filler plug</b> for empty terminal space, 35.6 mm design width, for terminal installation depth	11 mm	BC 35,6 BS U11 KMGY	2896209	50
	22 mm	BC 35,6 BS U22 KMGY	2896212	50
<b>Filler plug</b> for empty terminal space, 53.6 mm design width, for terminal installation depth	11 mm	BC 53,6 BS U11 KMGY	2896225	50
	22 mm	BC 53,6 BS U22 KMGY	2896238	50

**Design width 71.6 mm (4TE)**

Description	Type	Order No.	Pcs. / Pkt.
<b>Lower housing part</b>	BC 71,6 UT HBUS BK	2896267	10
<b>Upper housing part</b> , with vents, terminal installation depth 11.1 mm	BC 71,6 OT U11 KMGY	2896050	10
<b>Upper housing part</b> , with vents, terminal installation depth 22.35 mm	BC 71,6 OT U22 KMGY	2896063	10
<b>Housing cover</b> , permanently snapped onto the upper housing part, in the same light gray color as the housing	BC 71,6 DKL R KMGY	2896160	10
<b>Housing cover</b> , hinged, can be sealed, transparent, including fitted cover	BC 71,6 DKL S TRANS	2896128	10

**Accessories**

<b>DIN rail connector</b> , 16-pos., 18-pos. slot to the PCB	1 Slot	HBUS 71,6-16P-1S BK	2896296	10
<b>Power plug</b> for DIN rail connector, with 16 free cable ends with a cross section of 0.25 mm <sup>2</sup> , 500 mm long	Socket strip	BL2-2,54/16-ST	2896335	50
	Pin strip	SL2-2,54/16-ST	2896348	50
<b>Cover cap set</b> , 3-piece, for protecting empty DIN rail connectors		HBUS-B SET BK	2278173	10
<b>Filler plug</b> for empty terminal space, 17.6 mm design width, for terminal installation depth	11 mm	BC 17,6 BS U11 KMGY	2896186	50
	22 mm	BC 17,6 BS U22 KMGY	2896199	50
<b>Filler plug</b> for empty terminal space, 35.6 mm design width, for terminal installation depth	11 mm	BC 35,6 BS U11 KMGY	2896209	50
	22 mm	BC 35,6 BS U22 KMGY	2896212	50

**Design width 107.6 mm (6TE)**

Description	Type	Order No.	Pcs. / Pkt.
<b>Lower housing part</b>	BC 107,6 UT HBUS BK	2896270	10
<b>Upper housing part</b> , with vents, terminal installation depth 11.1 mm	BC 107,6 OT U11 KMGY	2896076	10
<b>Upper housing part</b> , with vents, terminal installation depth 22.35 mm	BC 107,6 OT U22 KMGY	2896089	10
<b>Housing cover</b> , permanently snapped onto the upper housing part, in the same light gray color as the housing	BC 107,6 DKL R KMGY	2896173	10
<b>Housing cover</b> , hinged, can be sealed, transparent, including fitted cover	BC 107,6 DKL S TRANS	2896131	10

**Accessories**

<b>DIN rail connector</b> , 16-pos., 18-pos. slot to the PCB	1 Slot	HBUS 107,6-16P-1S BK	2896306	10
<b>Power plug</b> for DIN rail connector, with 16 free cable ends with a cross section of 0.25 mm <sup>2</sup> , 500 mm long	Socket strip	BL2-2,54/16-ST	2896335	50
	Pin strip	SL2-2,54/16-ST	2896348	50
<b>Cover cap set</b> , 3-piece, for protecting empty DIN rail connectors		HBUS-B SET BK	2278173	10
<b>Filler plug</b> for empty terminal space, 17.6 mm design width, for terminal installation depth	11 mm	BC 17,6 BS U11 KMGY	2896186	50
	22 mm	BC 17,6 BS U22 KMGY	2896199	50
<b>Filler plug</b> for empty terminal space, 35.6 mm design width, for terminal installation depth	11 mm	BC 35,6 BS U11 KMGY	2896209	50
	22 mm	BC 35,6 BS U22 KMGY	2896212	50
<b>Filler plug</b> for empty terminal space, 53.6 mm design width, for terminal installation depth	11 mm	BC 53,6 BS U11 KMGY	2896225	50
	22 mm	BC 53,6 BS U22 KMGY	2896238	50

**Design width 161.6 mm (9TE)**

Description	Type	Order No.	Pcs. / Pkt.
<b>Lower housing part</b>	BC 161,6 UT HBUS BK	2278500	10
<b>Upper housing part</b> , with vents, terminal installation depth 11.1 mm	BC 161,6 OT U11 KMGY	2278513	10
<b>Upper housing part</b> , with vents, terminal installation depth 22.35 mm	BC 161,6 OT U22 KMGY	2278526	10
<b>Housing cover</b> , permanently snapped onto the upper housing part, in the same light gray color as the housing	BC 161,6 DKL R KMGY	2278539	10
<b>Housing cover</b> , hinged, can be sealed, transparent, including fitted cover	BC 161,6 DKL S TRANS	2278542	10

**Accessories**

<b>DIN rail connector</b> , 16-pos., 18-pos. slot to the PCB	1 Slot	HBUS 161,6-16P-1S BK	2278555	10
<b>Power plug</b> for DIN rail connector, with 16 free cable ends with a cross section of 0.25 mm <sup>2</sup> , 500 mm long	Socket strip	BL2-2,54/16-ST	2896335	50
	Pin strip	SL2-2,54/16-ST	2896348	50
<b>Cover cap set</b> , 3-piece, for protecting empty DIN rail connectors		HBUS-B SET BK	2278173	10
<b>Filler plug</b> for empty terminal space, 17.6 mm design width, for terminal installation depth	11 mm	BC 17,6 BS U11 KMGY	2896186	50
	22 mm	BC 17,6 BS U22 KMGY	2896199	50
<b>Filler plug</b> for empty terminal space, 35.6 mm design width, for terminal installation depth	11 mm	BC 35,6 BS U11 KMGY	2896209	50
	22 mm	BC 35,6 BS U22 KMGY	2896212	50
<b>Filler plug</b> for empty terminal space, 53.6 mm design width, for terminal installation depth	11 mm	BC 53,6 BS U11 KMGY	2896225	50
	22 mm	BC 53,6 BS U22 KMGY	2896238	50

### 3.2 Order key for BC 161,6 modular – upper part

With BC 161,6 modular, the side panel for each segment on each side of the housing can be arranged in three different positions.

- When the side panel is located at the innermost position, the installation space for connection technology is maximized to 22 mm (see Figure 4, pos. 1 and 2).
- In the middle side panel position there is 11 mm of space on the outside for the connection technology (see Figure 4, pos. 3 and 4).
- The maximum mounting surface for the PCB is available when the side panel of the upper housing part is flush with the outside edge of the lower housing part (see Figure 4, pos. 5 and 6)

Figure 4 Positions for order key

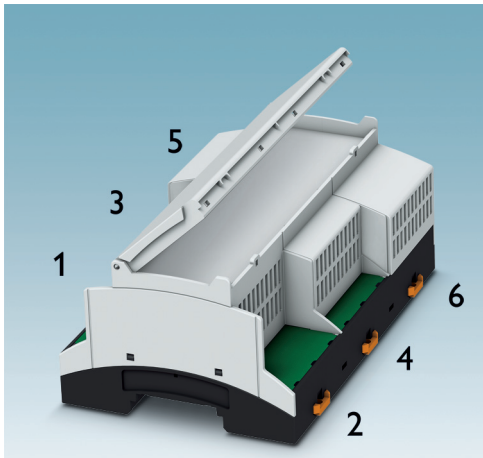

xxxxxxx	/BC 161,6 OT	/1 /2 /3 /4 /5 /6/	KMGY
No. is assigned by Phoenix Contact after receipt of the order		Location Side panel 0 = outside 1 = middle 2 = inside	Housing color: light gray

Example for Figure 4:

BC 161,6 OT 221100 KMGY

Side panel

- Locations 1 and 2: inside
- Locations 3 and 4: middle
- Locations 5 and 6: outside

### Ordering data for example configurations

#### Ordering data for upper part of BC 161,6 modular

Description	Type	Order No.	Pcs. / Pkt.
Upper housing part, with vents, 1 x terminal installation depth of 22 mm at pos. 5, all other terminal spaces closed	BC 161,6 OT 000020 KMGY	2201450	10
Upper housing part, with vents, 1 x terminal installation depth of 22 mm at pos. 3, all other terminal spaces closed	BC 161,6 OT 002000 KMGY	2201451	10
Upper housing part, with vents, 2 x terminal installation depth of 22 mm at pos. 5 and 6, all other terminal spaces closed	BC 161,6 OT 000022 KMGY	2201454	10

The corresponding lower housing part and the accessories can be found in the ordering data for design width 161.6 mm (9TE) (see page 6).

## 3.3 Selecting the right connection technology

Module	BC 17,8	BC 35,6		BC 53,6		BC 71,6		BC 107,6		BC 161,6	
		U11	U22	U11	U22	U11	U22	U11	U22	U11	U22
MKDSO 1,5/4-L-3,5	X	-	-	-	-	-	-	-	-	-	-
MKDSO 1,5/4-R-3,5	X	-	-	-	-	-	-	-	-	-	-
MKDSO 2,5/3-L	X	-	-	-	-	-	-	-	-	-	-
MKDSO 2,5/3-R	X	-	-	-	-	-	-	-	-	-	-
MKDS 1,5/... HT	-	X	X	X	X	X	X	X	X	X	X
MKDSN 2,5/... HT	-	X	X	X	X	X	X	X	X	X	X
MKDS 3/... HT	-	X	X	X	X	X	X	X	X	X	X
MKDS 1,5/...	-	X	X	X	X	X	X	X	X	X	X
MKDSP 1,5/...	-	X	X	X	X	X	X	X	X	X	X
MKDSN 2,5/...	-	X	X	X	X	X	X	X	X	X	X
MKDS 3/...	-	X	X	X	X	X	X	X	X	X	X
MKDSP 3/...	-	X	X	X	X	X	X	X	X	X	X
MKKDSH 3/...	-	X	X	X	X	X	X	X	X	X	X
GMKDS 1,5/...	-	X	X	X	X	X	X	X	X	X	X
GMKDS 3/...	-	X	X	X	X	X	X	X	X	X	X
GMKDSP 3/...	-	X	X	X	X	X	X	X	X	X	X
SPTA 1/...-3,5	-	X	X	X	X	X	X	X	X	X	X
SPTA 1/...-5,0	-	X	X	X	X	X	X	X	X	X	X
MKKDS 1,5/...	-	-	X	-	X	-	X	-	X	-	X
MKKDS 3/...	-	-	X	-	X	-	X	-	X	-	X
MKKDSG 3/...	-	-	X	-	X	-	X	-	X	-	X
ZFKKDS 1,5C-5,0	-	-	X	-	X	-	X	-	X	-	X
FK-MPT 0,5/...-3,5-H	-	X	X	X	X	X	X	X	X	X	X
FK-MPT 0,5/...-ST-3,5	-	X	X	X	X	X	X	X	X	X	X
PTSA 0,5/...-2,5-Z	-	X	X	X	X	X	X	X	X	X	X
PTSA 0,5/...-2,5-F	-	X	X	X	X	X	X	X	X	X	X
PTSA 1,5/...-3,5-Z	-	X	X	X	X	X	X	X	X	X	X
PTSA 1,5/...-3,5-F	-	X	X	X	X	X	X	X	X	X	X
PTS 1,5/...-5,0-H	-	X	X	X	X	X	X	X	X	X	X
PT 1,5/...-5,0-H	-	X	X	X	X	X	X	X	X	X	X
PT 1,5/...-PH-5,0	-	X	X	X	X	X	X	X	X	X	X
PT 1,5/...-5,0-H	-	X	X	X	-	X	X	X	X	X	X
PT 2,5/4-7,5-H	-	X	X	X	X	X	X	X	X	X	X
PTDA 1,5/...-PH-3,5	-	-	X	-	X	-	X	-	X	-	X
PTDA 1,5/...-PH-5,0	-	-	X	-	X	-	X	-	X	-	X
PT 2,5/...-PVH-5,0	-	-	X	-	X	-	X	-	X	-	X
PST 1,3/...-LH-5,0	-	-	X	-	X	-	X	-	X	-	X
PST 1,3/...-LV-5,0	-	-	X	-	X	-	X	-	X	-	X
PST 1,0/...-3,5	-	X	X	X	X	X	X	X	X	X	X
PST 1,3/...-5,0	-	X	X	X	X	X	X	X	X	X	X
VS-08-BU-RJ45...	-	-	X	-	X	-	X	-	X	-	X

## 4 Technical data

### Electrical data

Power dissipation  $P_V$  at 20°C in the horizontal mounting position, aligned without distance

BC 17,8	2.95 W
BC 35,6	4.78 W
BC 53,6	7.21 W
BC 71,6	11.95 W
BC 107,6	13.08 W
BC 161,6	16.95 W

DIN rail connector HBUS

60 V

DIN rail connector HBUS, current carrying capacity for each contact

3 A, maximum total current 25 A

### Housing version

Insulation material	Polycarbonate
Inflammability class according to UL 94	V0
Color of lower housing part	Black
Color of upper housing part	Light gray

## 5 Safety notes

Only electrically qualified personnel may install and operate the housing. The qualified personnel must be able to recognize and prevent danger.

Do not connect or disconnect the connectors under load.

Do not connect or disconnect the DIN rail connector under load.

Only put products into use that are free of faults. Check the products regularly for damage. Immediately take defective products out of service. Replace damaged products. Repairs are not possible.

## 6 Housing dimensions

### 6.1 Dimensions of housing

Figure 5 BC...U11, side view

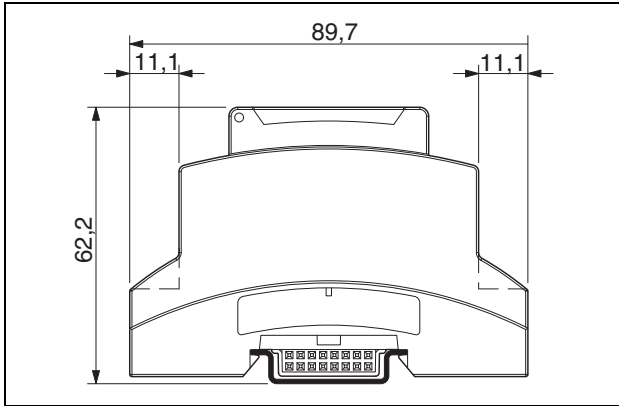

Figure 6 BC...U22, side view

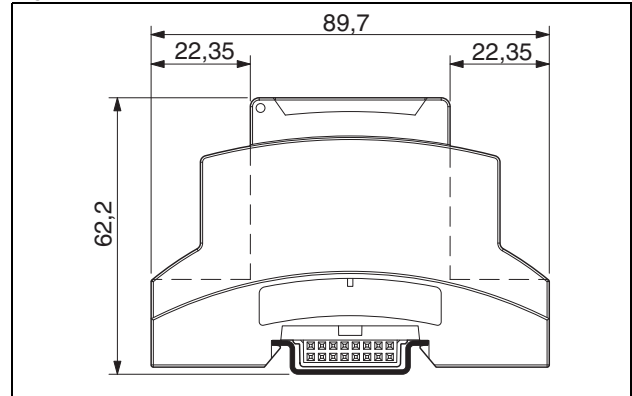
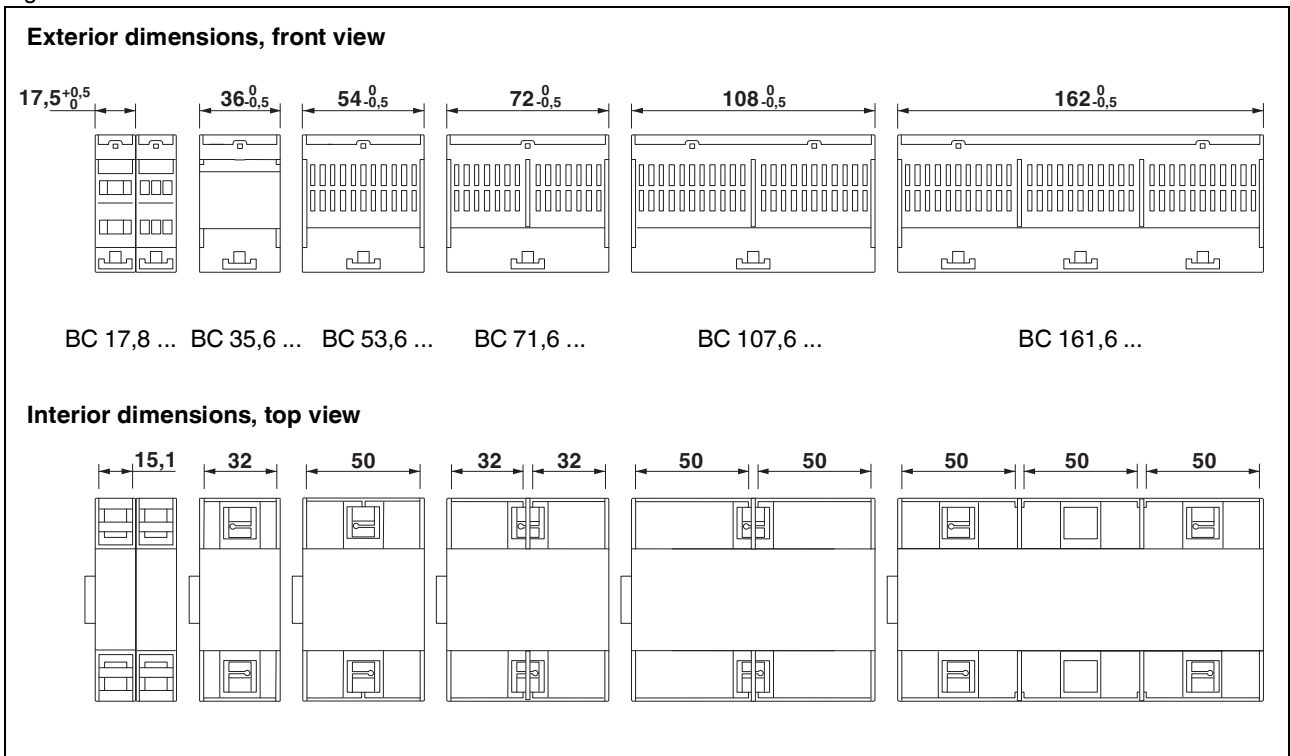
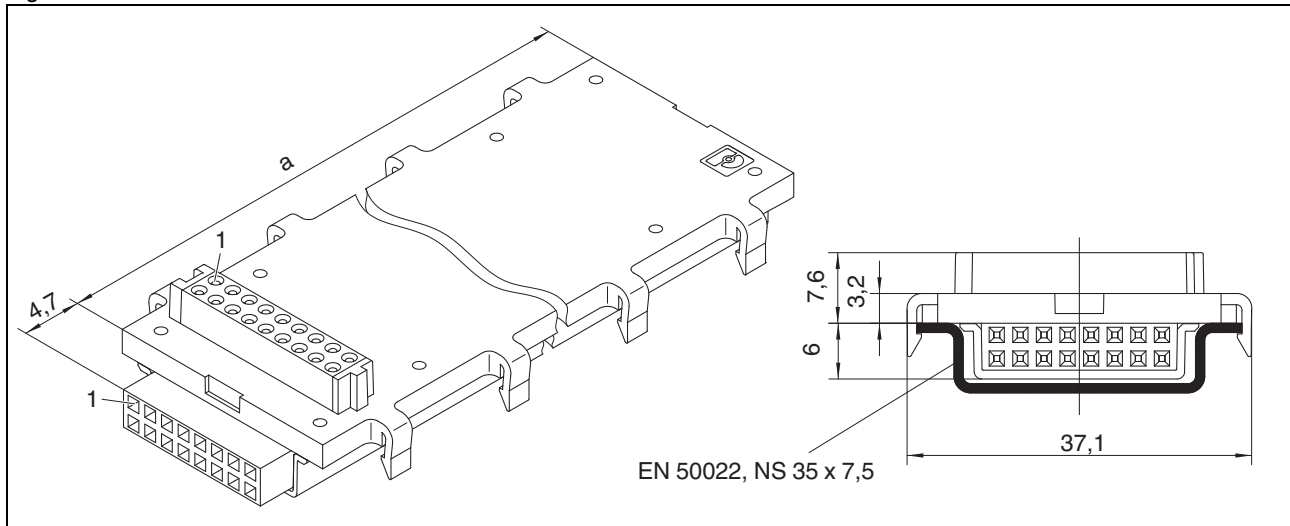

Figure 7 Exterior and interior dimensions



## 6.2 Dimensions of DIN rail connector

Figure 8 Dimensions of DIN rail connector HBUS and DIN rail NS 35



### Dimensions for a

HBUS 35,6-16P-1S BK	35.6 mm
HBUS 35,6-16P-2S BK	35.6 mm
HBUS 53,6-16P-1S BK	53.6 mm
HBUS 53,6-16P-3S BK	53.6 mm
HBUS 71,6-16P-1S BK	71.6 mm
HBUS 161,6-16P-1S BK	161.6 mm

## 7 PCB arrangement for BC 17,8 (1TE)

### 7.1 PCB dimensions

Figure 9 Upper side – mounting side of BC 17,8

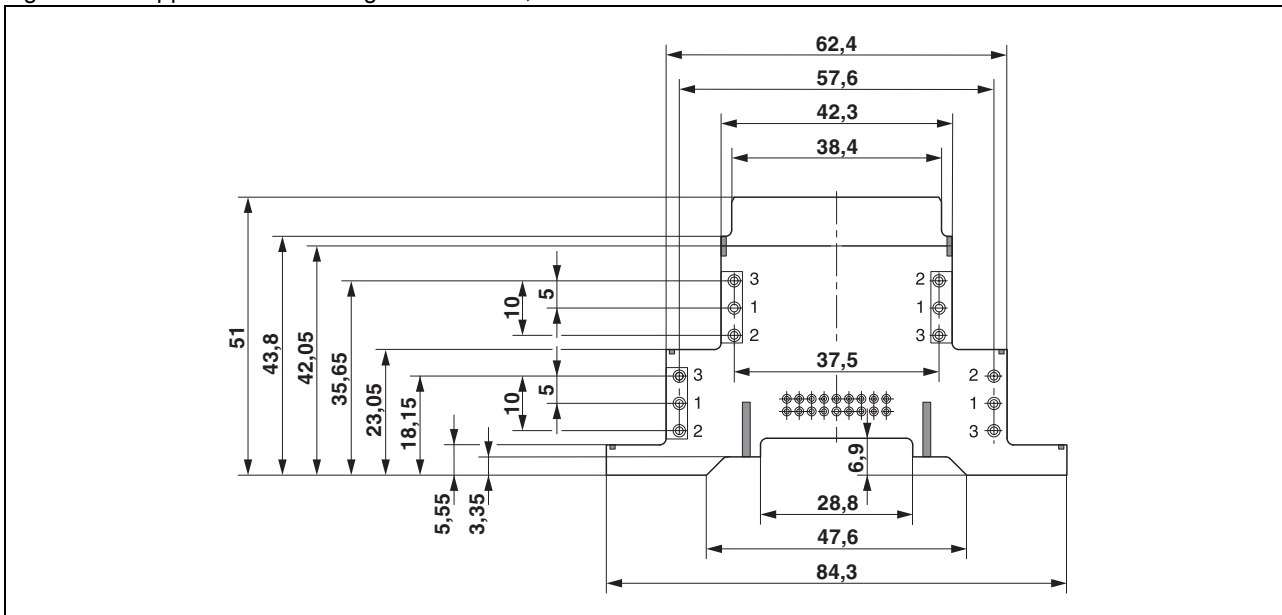



<b>PCB thickness</b>	Maximum 1.5 mm
	Locked area, no components at these positions

Figure 10 Lower side – soldering side of BC 17,8

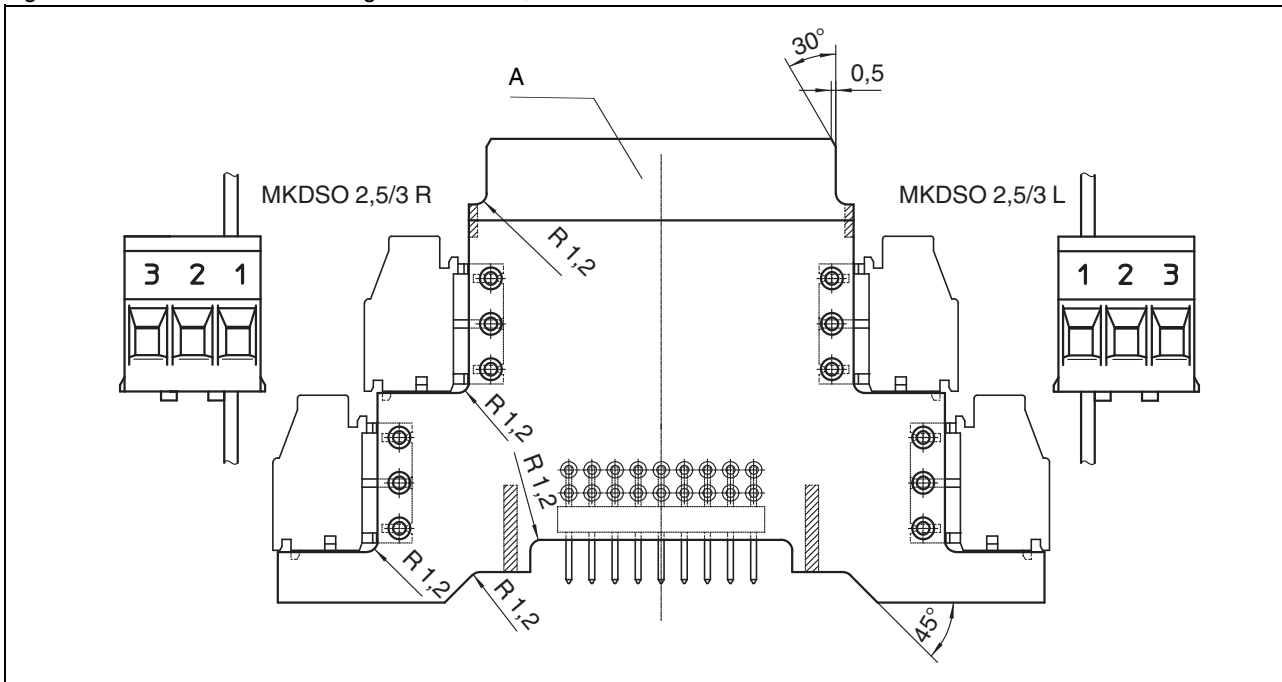

<b>A</b>	PCB surface, when no fitted cover is used
<b>PCB thickness</b>	Maximum 1.5 mm
	Locked area, no components at these positions

## 7.2 Inner dimensions

Figure 11 Inner dimensions BC 17,8

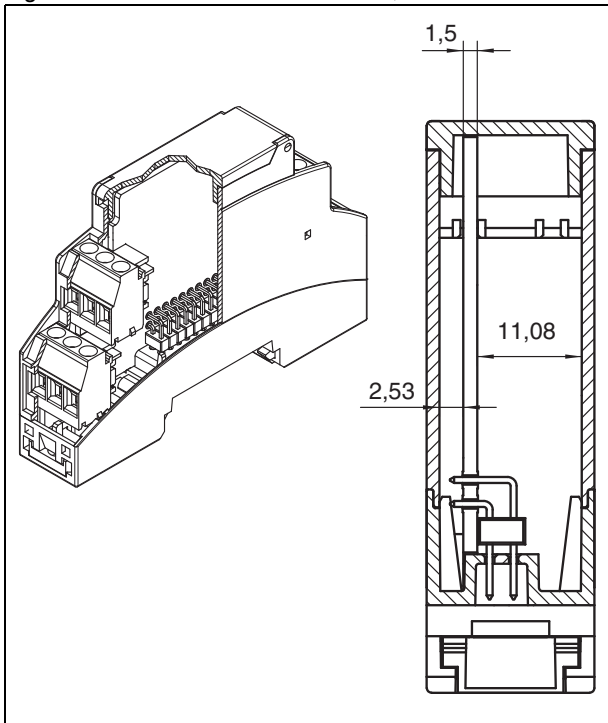

**7.3 Circuit diagram of DIN rail connector with 2 and 3 slots**

Figure 12 Circuit diagram HBUS 35,6-16P-2S BK

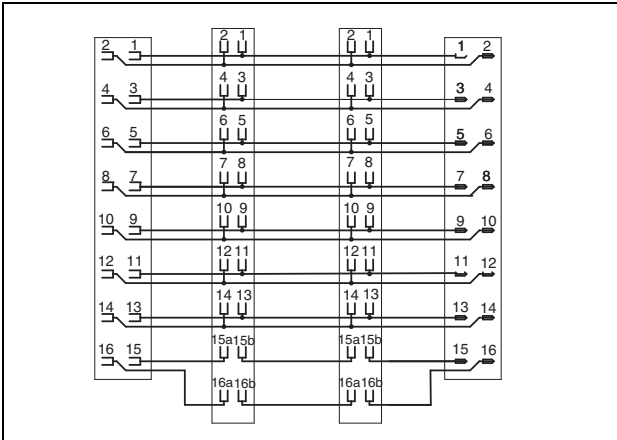
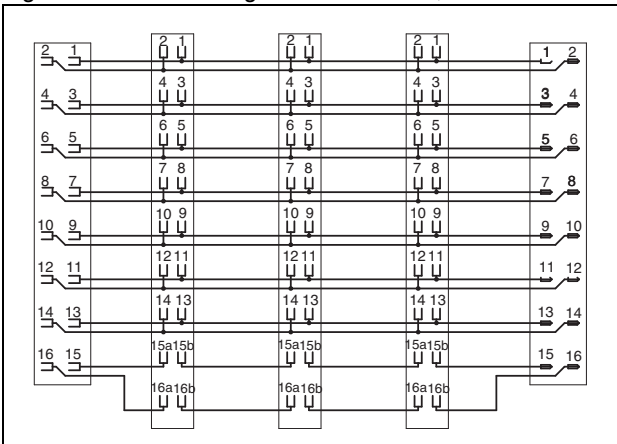

Figure 13 Circuit diagram for HBUS 53,6-16P-3S BK



**Contacts**

Contact 1 ... 4 Power  
Contact 5 ... 16 Signal

**Air and creepage distances**

... to the DIN rail min. 0.23 mm  
... between one another min. 0.13 mm  
... between power and signal min. 0.8 mm

**Current carrying capacity for each contact**

3 A, maximum total current 25 A

**7.4 Dimensional drawing of connector for DIN rail connector**

Figure 14 Dimensional drawing of connector on perpendicular PCB (in BC 17,8) for contacting in the DIN rail connector

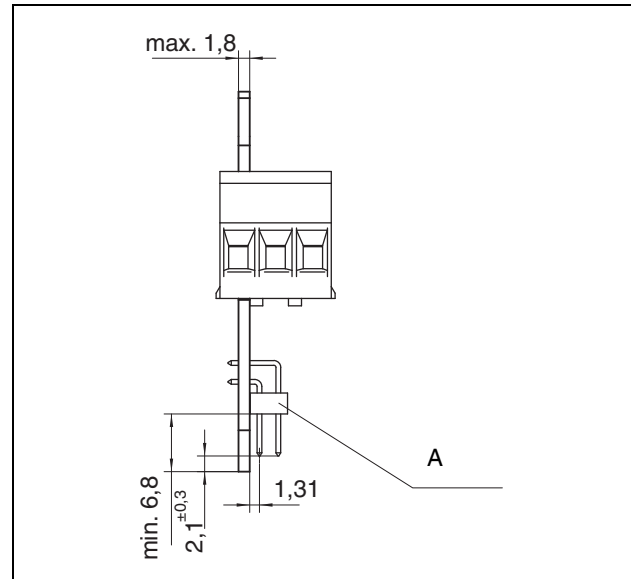

- A** Pin strip, max. 2 x 9-pos.
- 0.63 x 0.63 mm or ø 0.7 – 0.8 mm
- 2.54 mm pitch
- Gold-plated surface

**7.5 Safety notes**

Do not connect or disconnect the DIN rail connector under load.

Protect unused terminal points with a cover cap set (HBUS-B SET BK, 2278173).

**7.6 Derating**

Figure 15 Derating

## 8 PCB arrangement for BC 2TE – 9TE

### 8.1 Plug-in positions for horizontal PCBs

Figure 16 Overview of the PCB plug-in positions

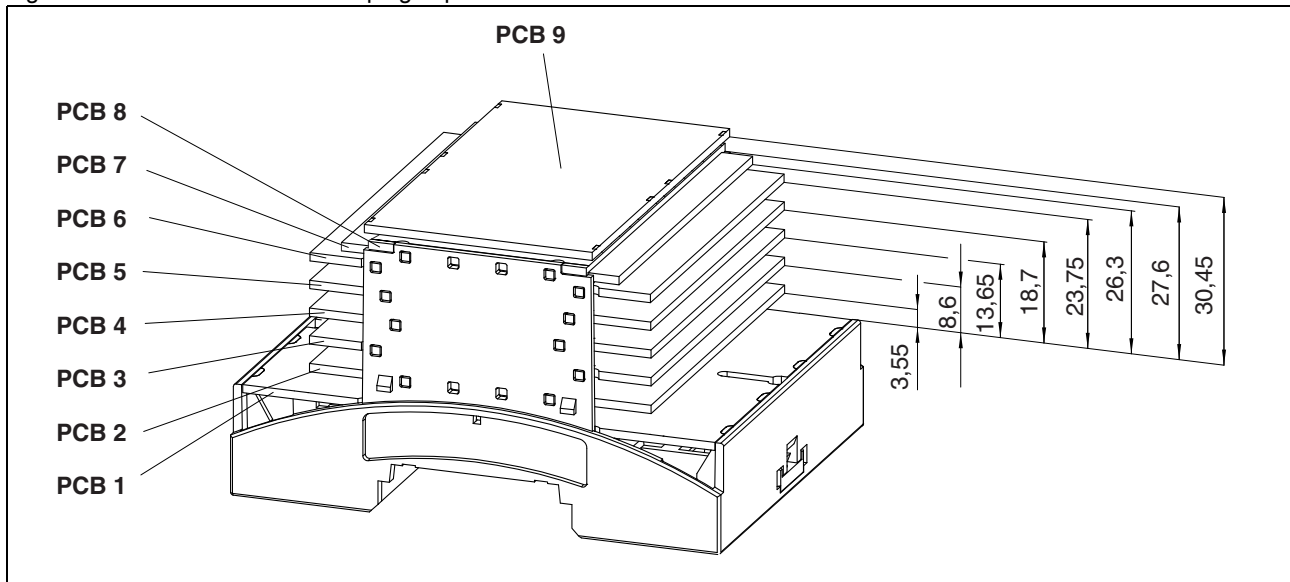

#### PCB thickness

PCB 1	1.5 mm ... 1.8 mm
PCB 2 – 8	Maximum 1.8 mm
PCB 9	Maximum 1.8 mm

A circuit board at PCB 9 is only possible when a fitted cover is not used. The fitted cover is supplied as standard with the transparent cover.

8.2 Circuit board dimensions for PCB 1, horizontal

Circuit board dimensions for PCB 1, horizontal (BC 35,6...)

An overview of the arrangement of the horizontal circuit boards PCB 1 – 9 can be found on [page 16](#).

Figure 17 Dimensions of PCB 1 (BC 35,6)

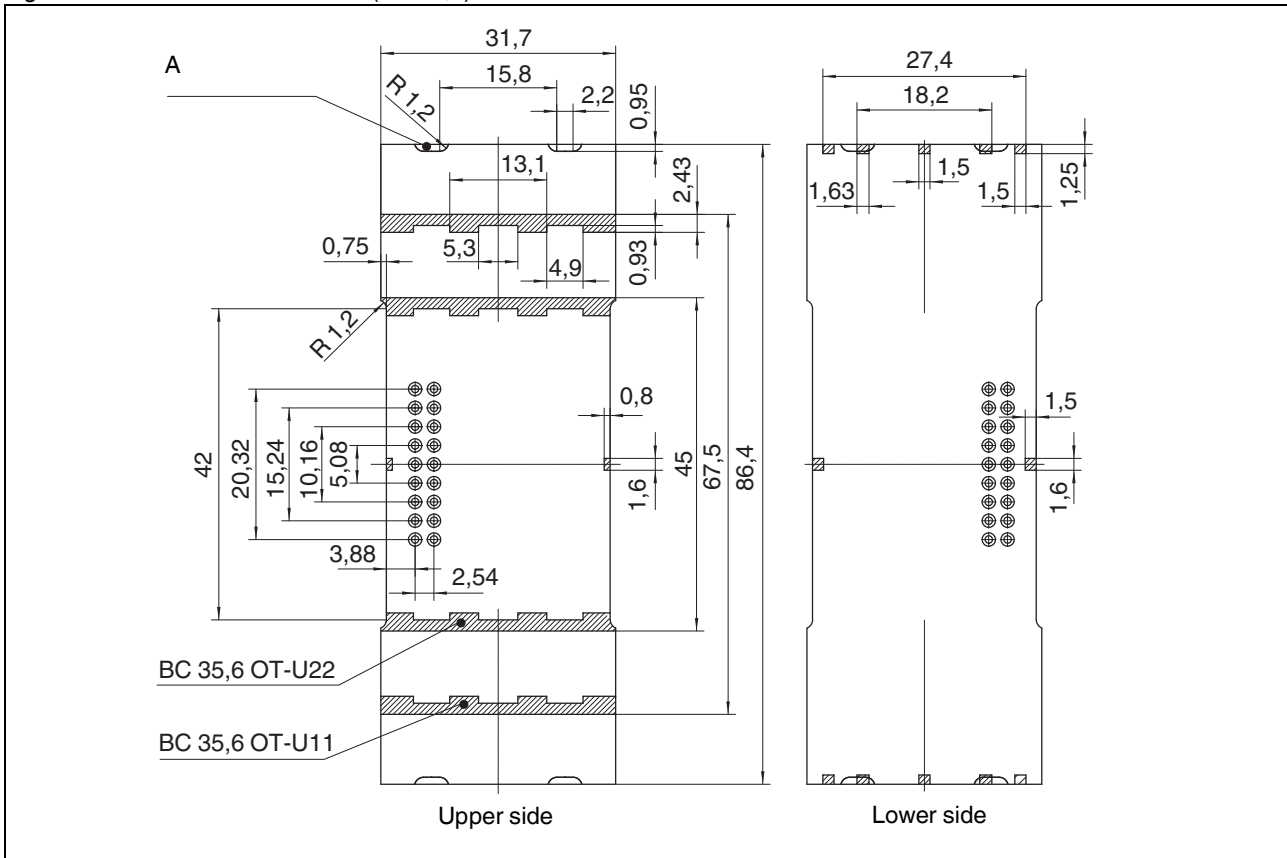



<b>A</b>	Contour for filler plug
<b>PCB thickness</b>	Maximum 1.8 mm
	Locked area, no components at these positions

**Circuit board dimensions for PCB 1, horizontal (BC 53,6...)**

An overview of the arrangement of the horizontal circuit boards PCB 1 – 9 can be found on [page 16](#).

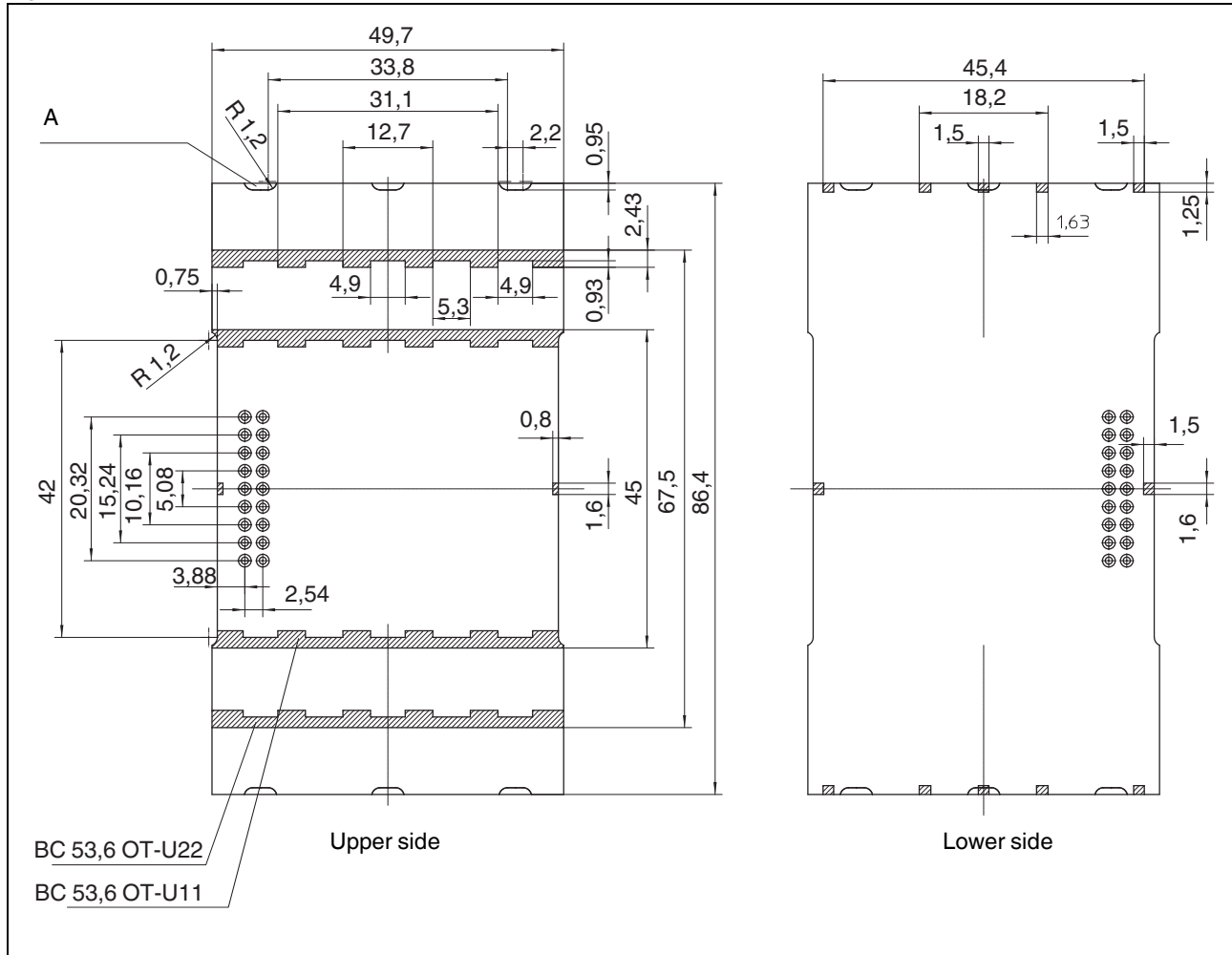
Figure 18 Dimensions of PCB 1 (BC 53,6)



<b>A</b>	Contour for filler plug
<b>PCB thickness</b>	Maximum 1.8 mm
	Locked area, no components at these positions

**Circuit board dimensions for PCB 1, horizontal (BC 71,6...)**

An overview of the arrangement of the horizontal circuit boards PCB 1 – 9 can be found on [page 16](#).

Figure 19 Dimensions of PCB 1 (BC 71,6) – upper side

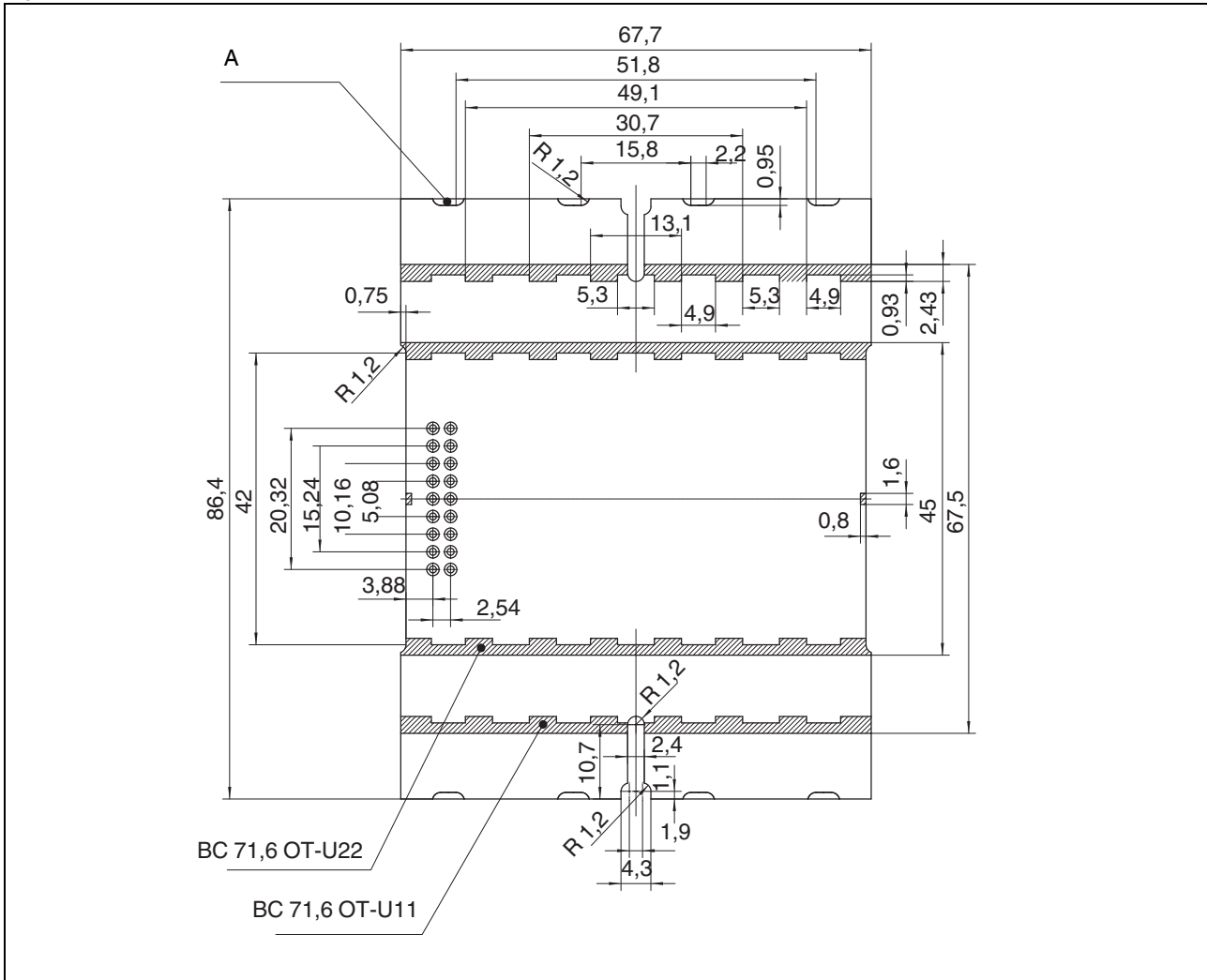



<b>A</b>	Contour for filler plug
<b>PCB thickness</b>	Maximum 1.8 mm
	Locked area, no components at these positions

Figure 20 Dimensions of PCB 1 (BC 71,6) – lower side

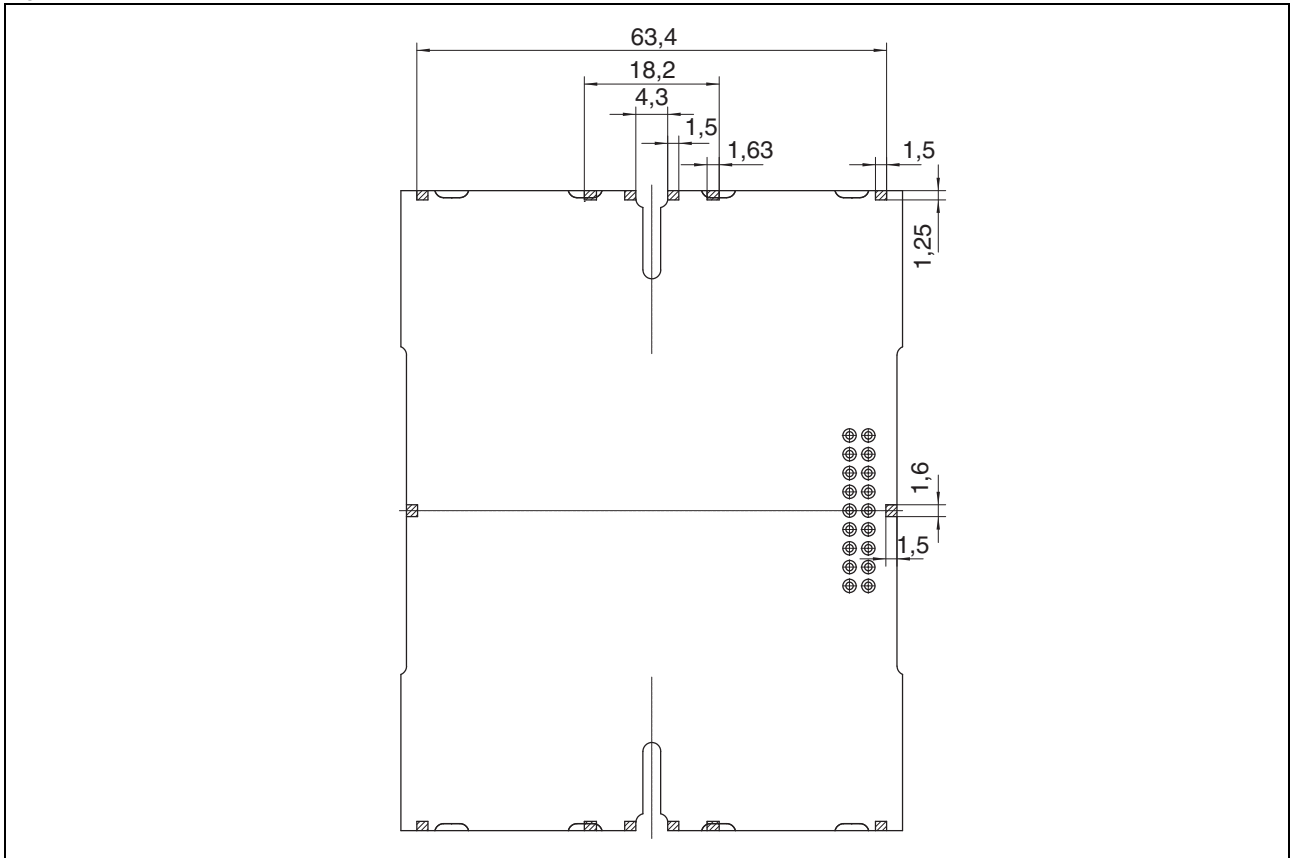

**PCB thickness** Maximum 1.8 mm

 Locked area, no components at these positions

**Circuit board dimensions for PCB 1, horizontal (BC 107,6...)**

An overview of the arrangement of the horizontal circuit boards PCB 1 – 9 can be found on [page 16](#).

Figure 21 Dimensions of PCB 1 (BC 107,6) – upper side

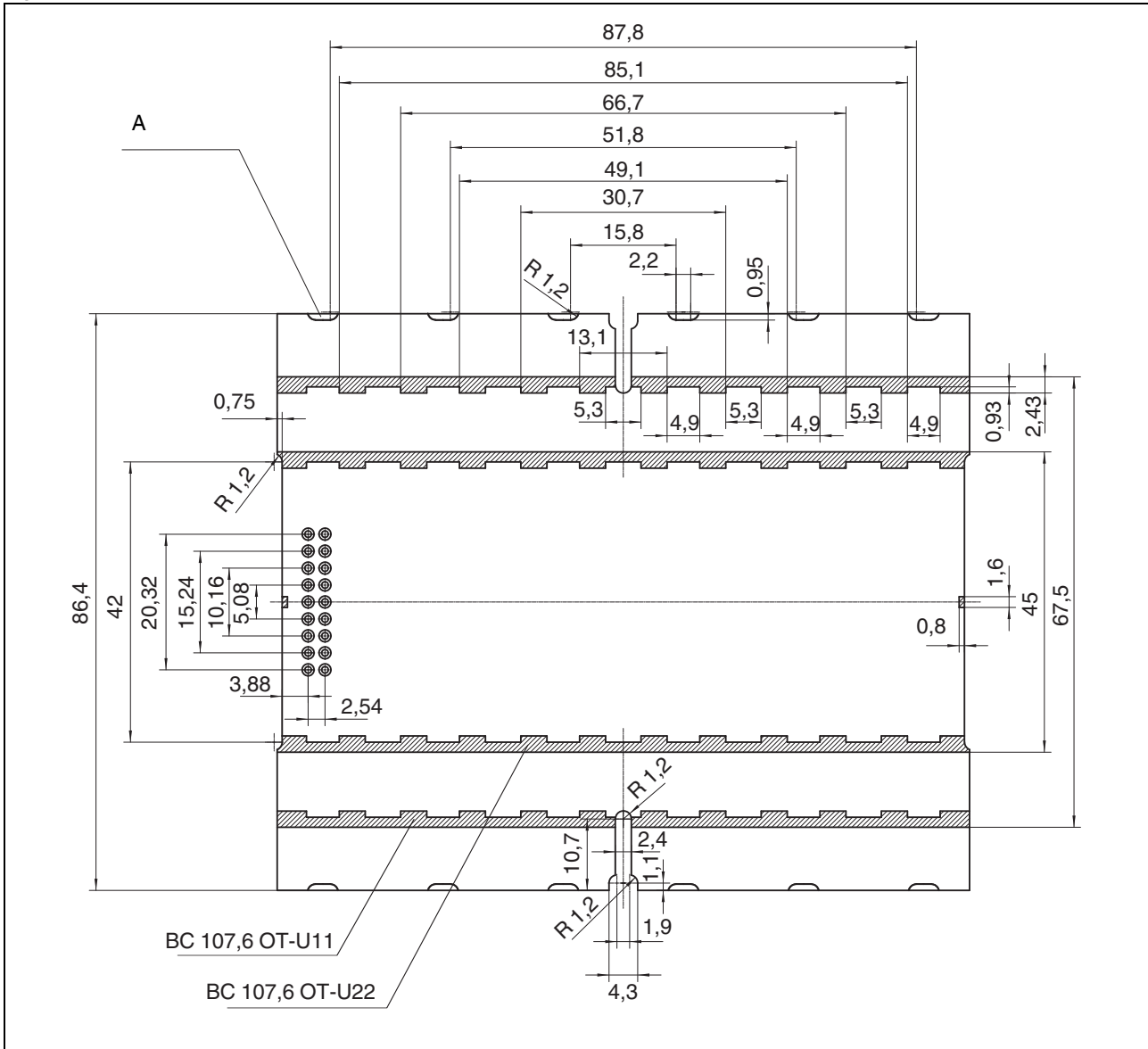



<b>A</b>	Contour for filler plug
<b>PCB thickness</b>	Maximum 1.8 mm
	Locked area, no components at these positions

Figure 22 Dimensions of PCB 1 (BC 107,6) – lower side

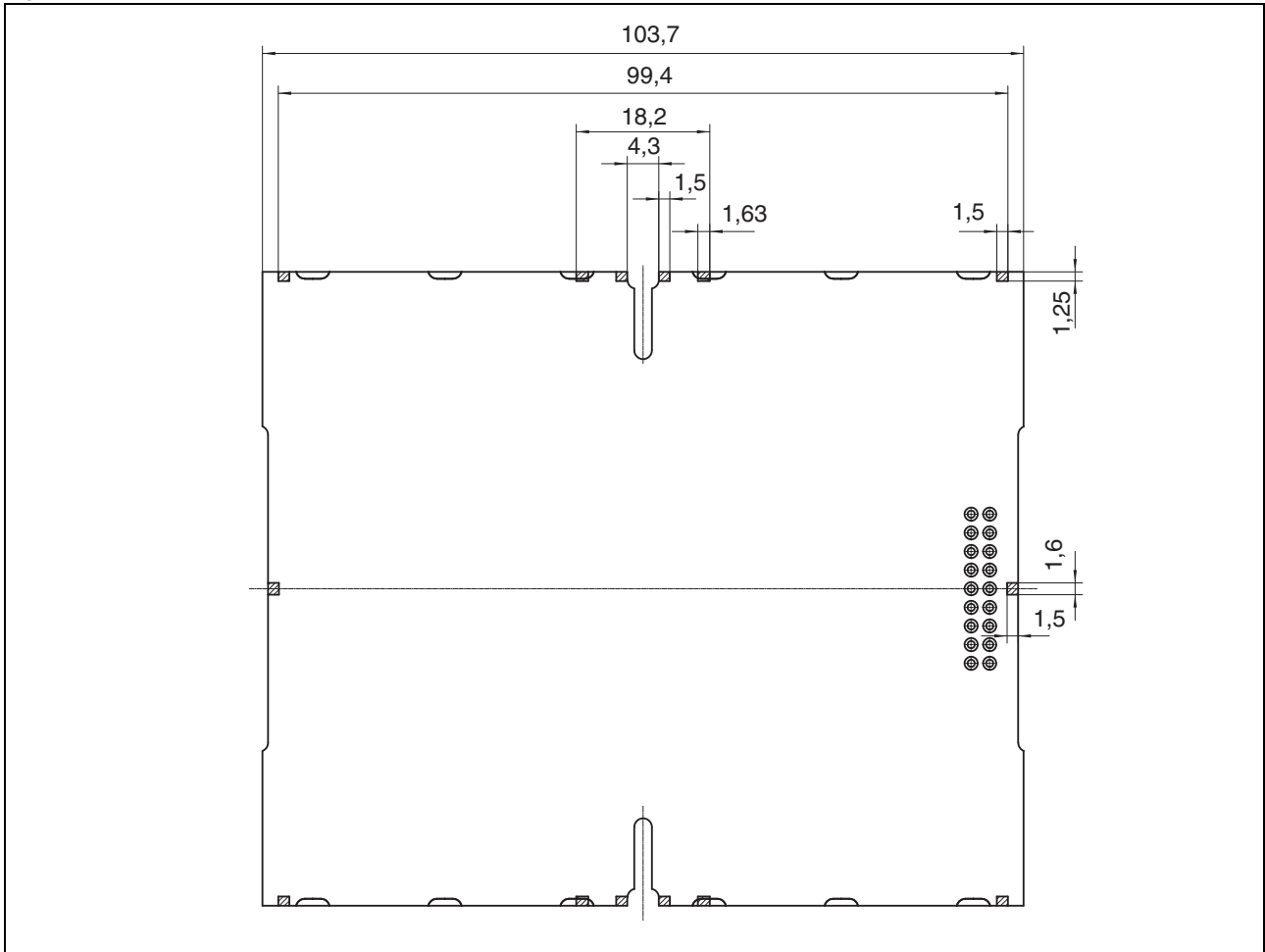

**PCB thickness** Maximum 1.8 mm

 Locked area, no components at these positions

**Circuit board dimensions for PCB 1, horizontal (BC 161,6...)**

An overview of the arrangement of the horizontal circuit boards PCB 1 – 9 can be found on [page 16](#).

Figure 23 Dimensions of PCB 1 (BC 161,6) – upper side

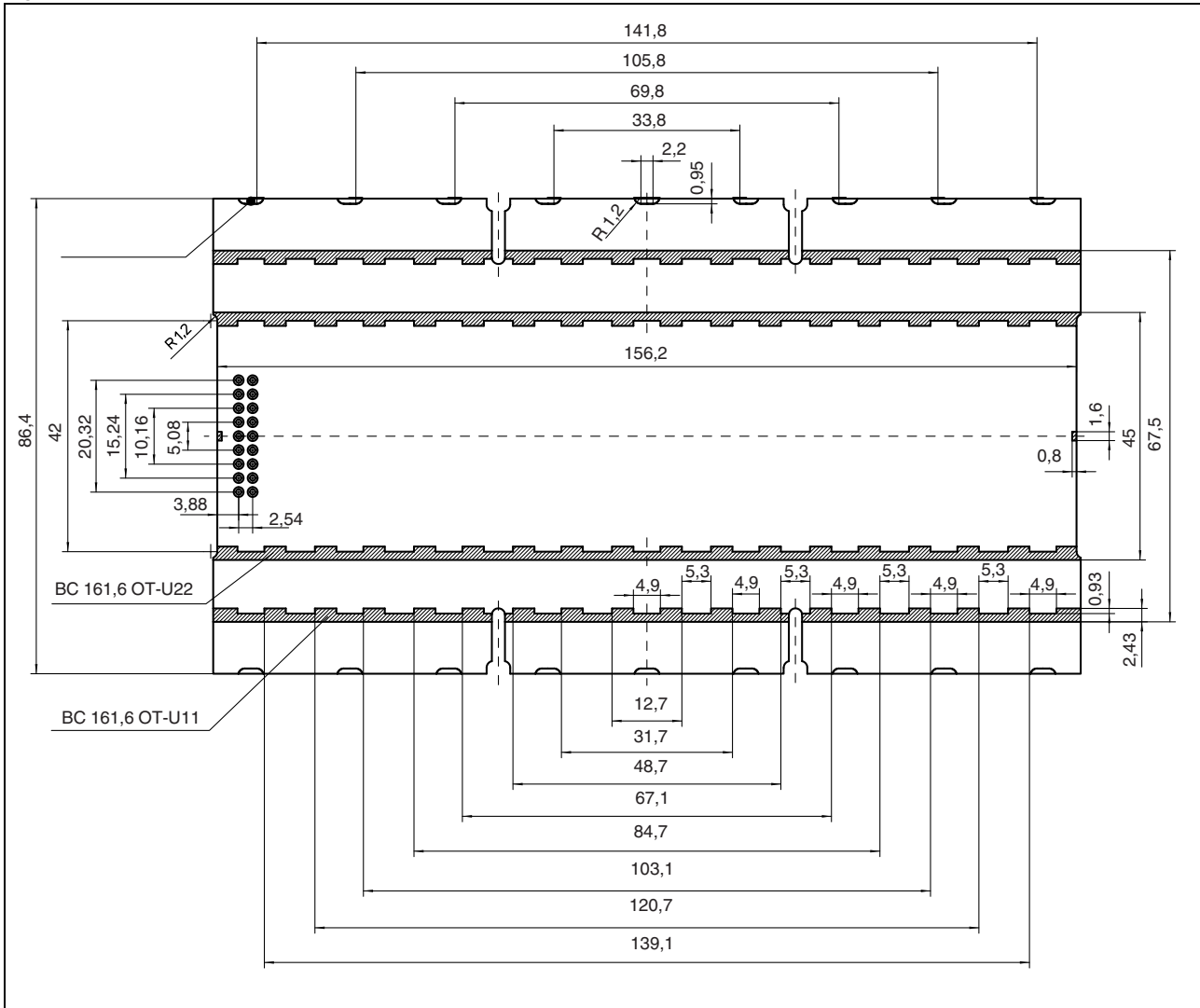

**PCB thickness** Maximum 1.8 mm  
 Locked area, no components at these positions



### 8.3 Circuit board dimensions for PCB 2 to 8, horizontal

An overview of the arrangement of the horizontal circuit boards PCB 1 – 9 can be found on [page 16](#).

Figure 25 Dimensions of PCB 2

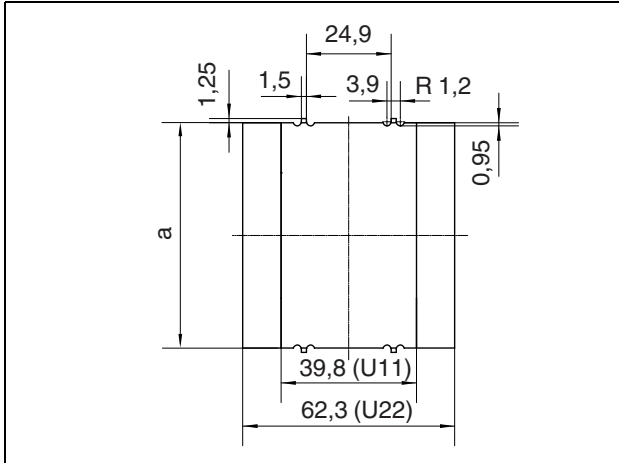

Figure 26 Dimensions of PCB 3

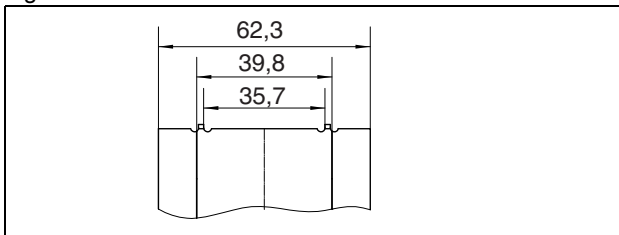

Figure 27 Dimensions of PCB 4

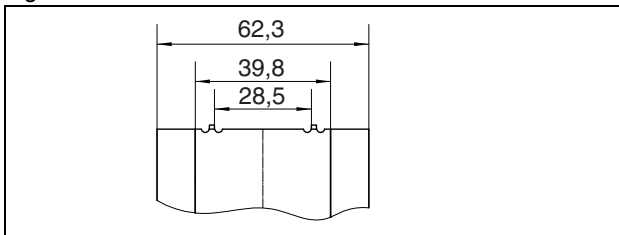

Figure 28 Dimensions of PCB 5

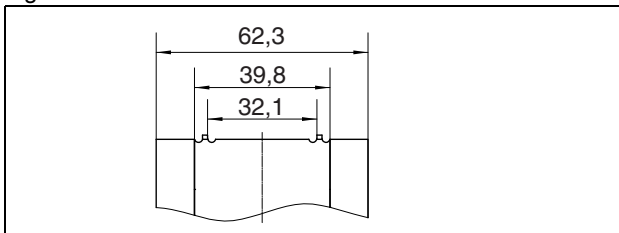

Figure 29 Dimensions of PCB 6

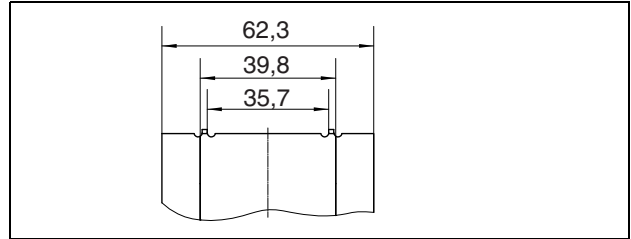

Figure 30 Dimensions of PCB 7

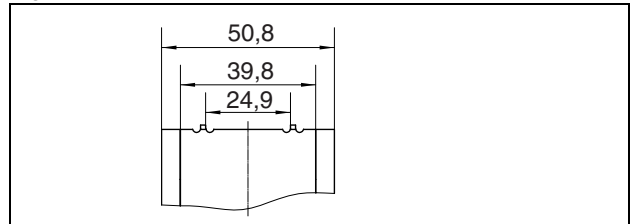
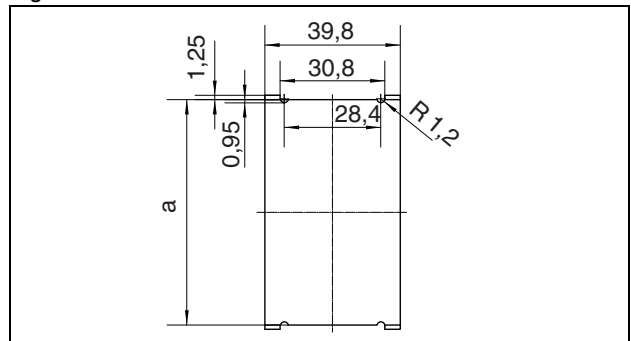

Figure 31 Dimensions of PCB 8



#### Dimensions for a

BC 35,6 UT	30.3
BC 53,6 UT	48.3
BC 71,6 UT	66.3
BC 71,6 UT	102.3
BC 161,6 UT	156.3

#### PCB thickness

Maximum 1.8 mm

### 8.4 Circuit board dimensions for PCB 9, horizontal

A circuit board at PCB 9 is only possible when a fitted cover is not used. The fitted cover is supplied as standard with the transparent cover.

An overview of the arrangement of the horizontal circuit boards PCB 1 – 9 can be found on [page 16](#).

#### Circuit board dimensions for PCB 9, horizontal (BC 35,6...)

Figure 32 Dimensions of PCB 9 (BC 35,6)

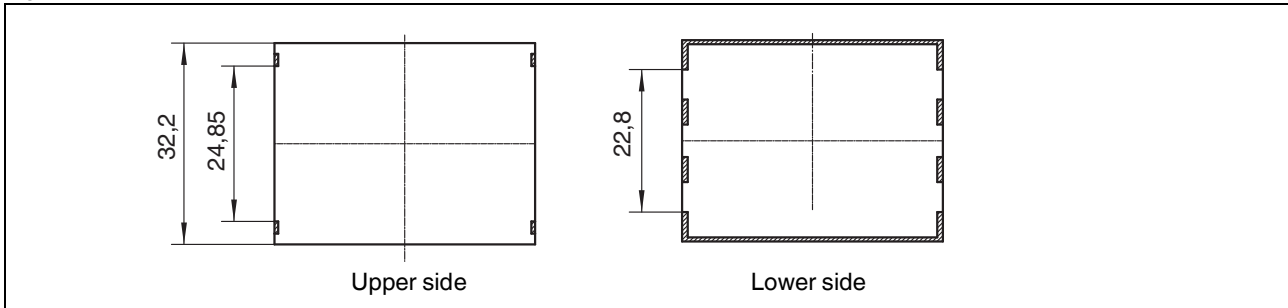

#### Circuit board dimensions for PCB 9, horizontal (BC 53,6...)

Figure 33 Dimensions of PCB 9 (BC 53,6)

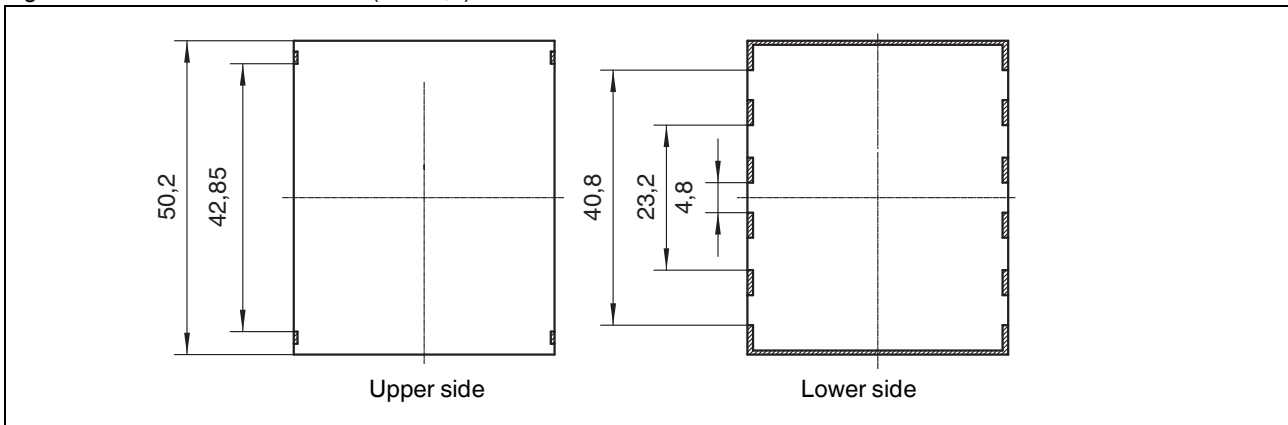

<b>PCB thickness</b>	Maximum 1.8 mm
	Locked area, no components at these positions

**Circuit board dimensions for PCB 9, horizontal (BC 71,6...)**

An overview of the arrangement of the horizontal circuit boards PCB 1 – 9 can be found on [page 16](#).

Figure 34 Dimensions of PCB 9 (BC 71,6)

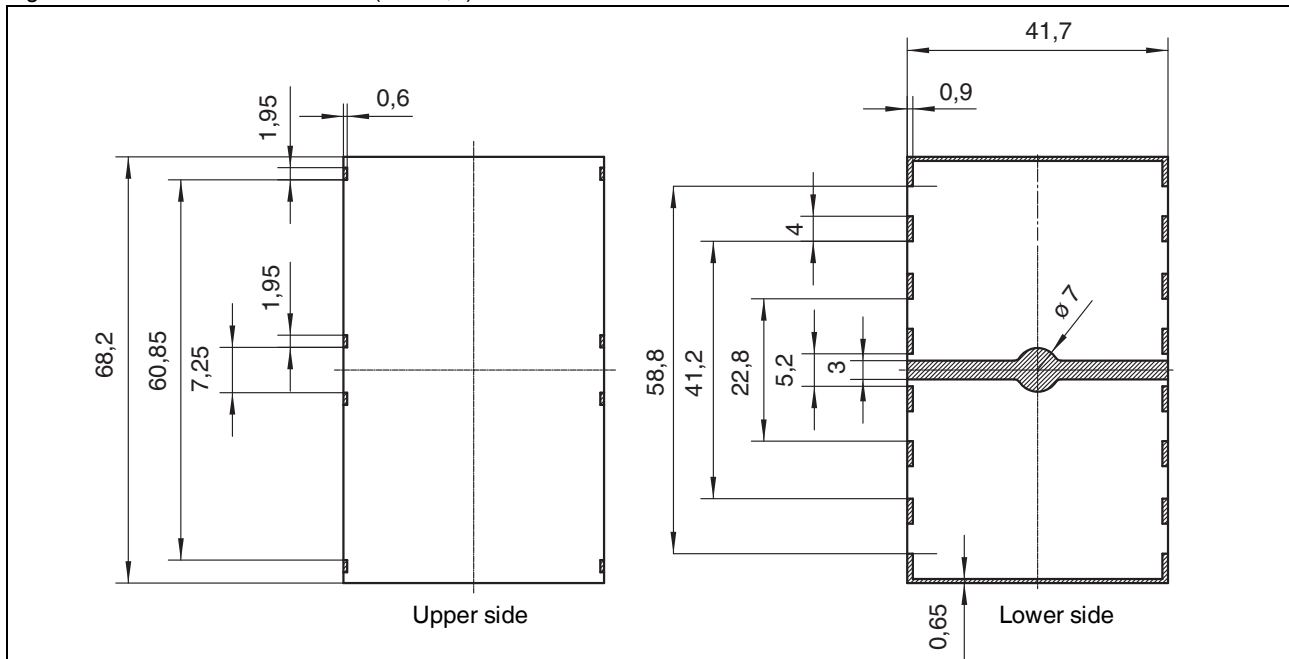

**PCB thickness**

Maximum 1.8 mm



Locked area, no components at these positions

**Circuit board dimensions for PCB 9, horizontal (BC 107,6...)**

An overview of the arrangement of the horizontal circuit boards PCB 1 – 9 can be found on [page 16](#).

Figure 35 Dimensions of PCB 9 (BC 107,6)

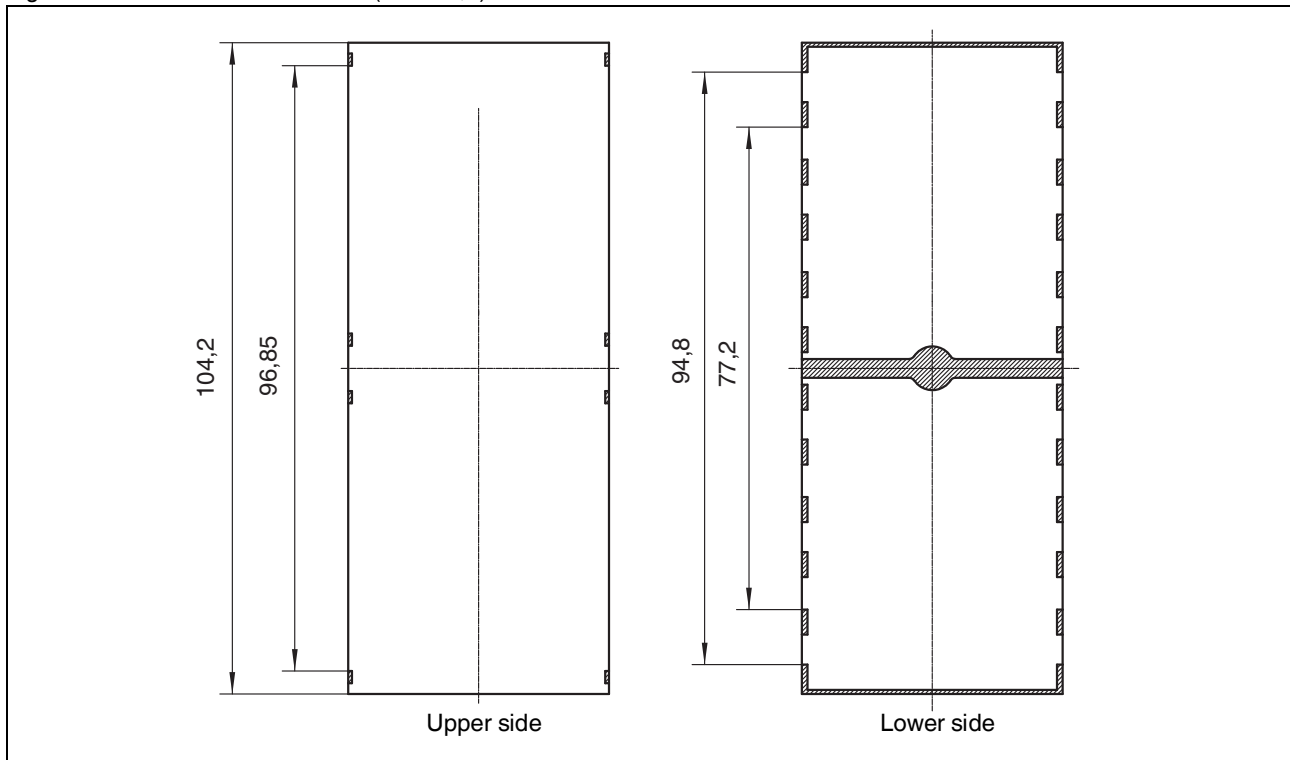
**PCB thickness**

Maximum 1.8 mm





Locked area, no components at these positions

**Circuit board dimensions for PCB 9, horizontal (BC 161,6...)**

An overview of the arrangement of the horizontal circuit boards PCB 1 – 9 can be found on [page 16](#).

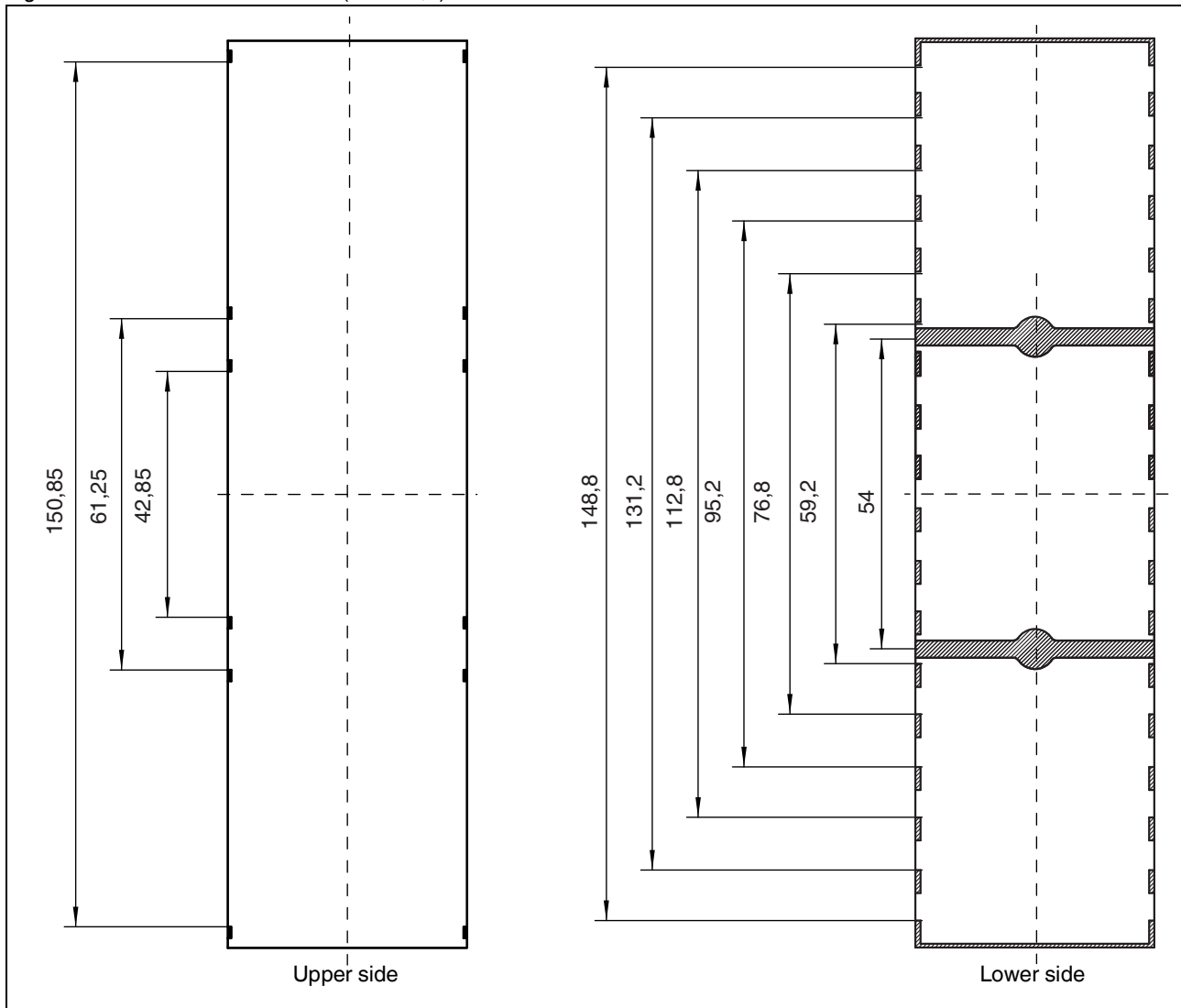
Figure 36 Dimensions of PCB 9 (BC 161,6)



**PCB thickness** Maximum 1.8 mm  
 Locked area, no components at these positions

8.5 Perpendicular PCBs – transverse to the DIN rail

Figure 37 Dimensions of BC...U11

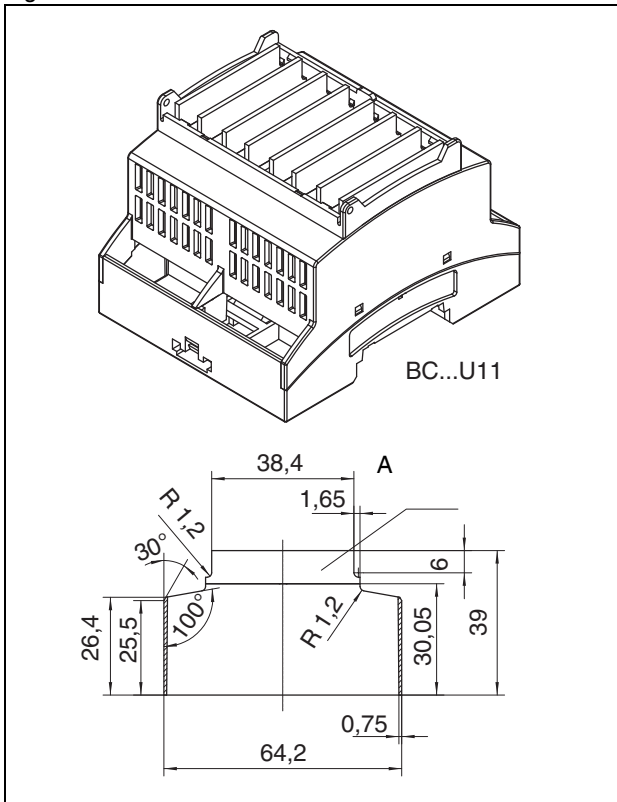
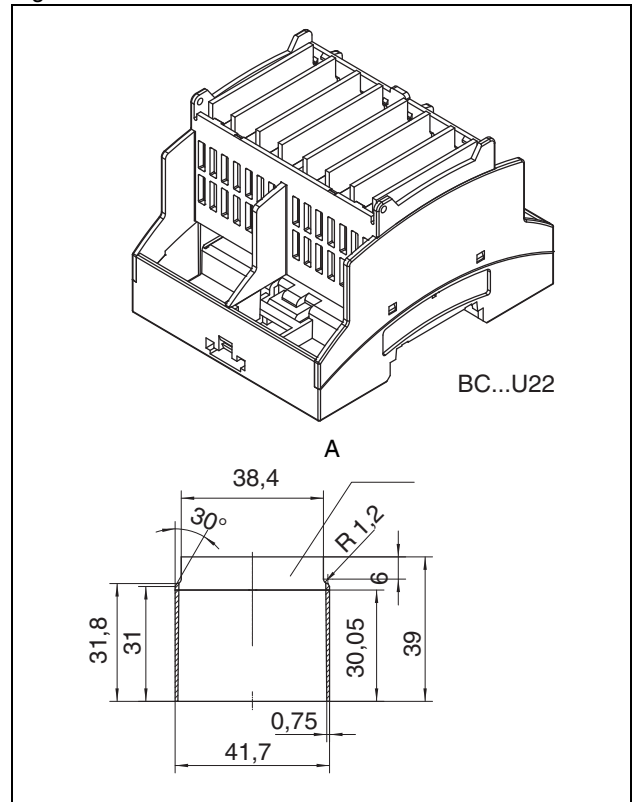

Figure 38 Dimensions of BC...U22



**PCB thickness**

Maximum 1.8 mm



Locked area, no components at these positions

**A**

PCB surface, when no fitted cover is used

Figure 39 Cross-sectional view - perpendicular PCBs

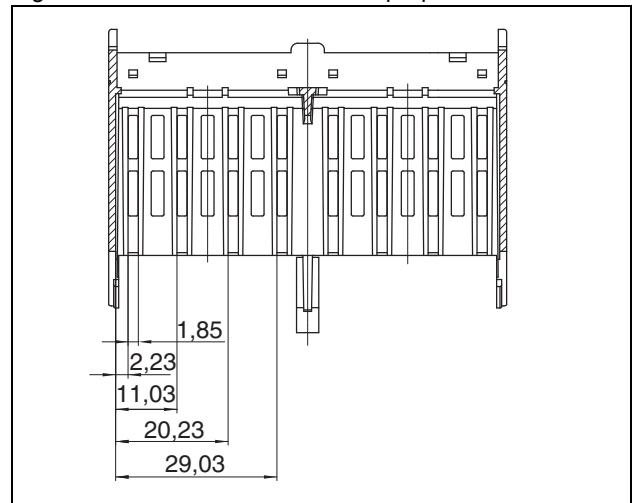

8.6 Perpendicular PCBs – parallel to the DIN rail

Figure 40 Perpendicular PCBs arranged parallel to the DIN rail

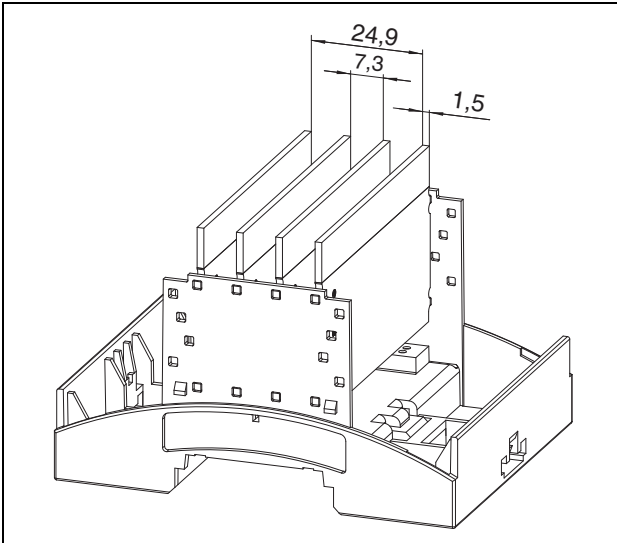
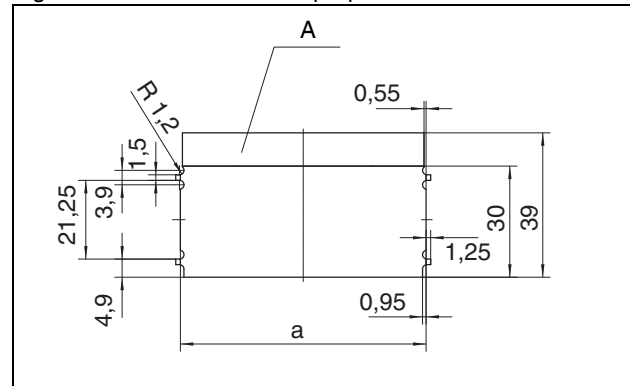

Figure 41 Dimensions for perpendicular PCBs



**Dimensions for a**

BC 35,6 UT	30.3
BC 53,6 UT	48.3
BC 71,6 UT	66.3
BC 71,6 UT	102.3
BC 161,6 UT	156.3

**PCB thickness**

Maximum 1.8 mm



Locked area, no components at these positions

**A**

PCB surface, when no fitted cover is used

## 9 PCB arrangement for BC 161,6 modular

### 9.1 Plug-in positions for horizontal PCBs

Figure 42 Overview of the plug-in positions for horizontal PCBs

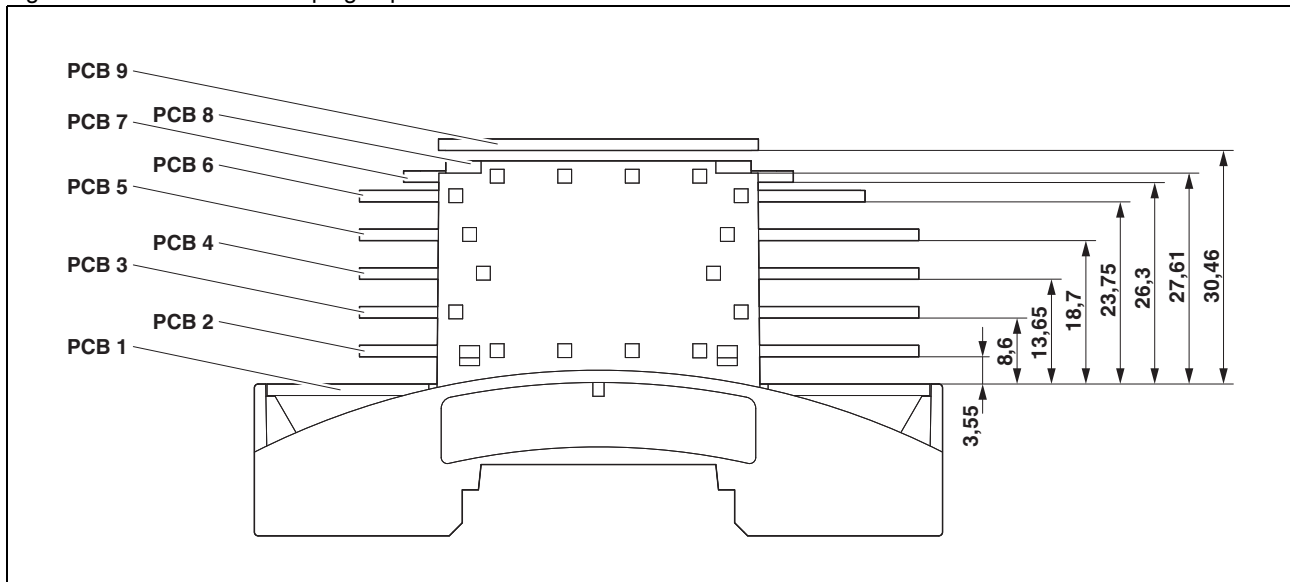

#### PCB thickness

PCB 1	Maximum 1.8 mm
PCB 2 – 8	Maximum 1.8 mm
PCB 9	Maximum 1.8 mm

## 9.2 Versions for the terminal installation space

Figure 43 Terminal installation depth 0, 1 and 2

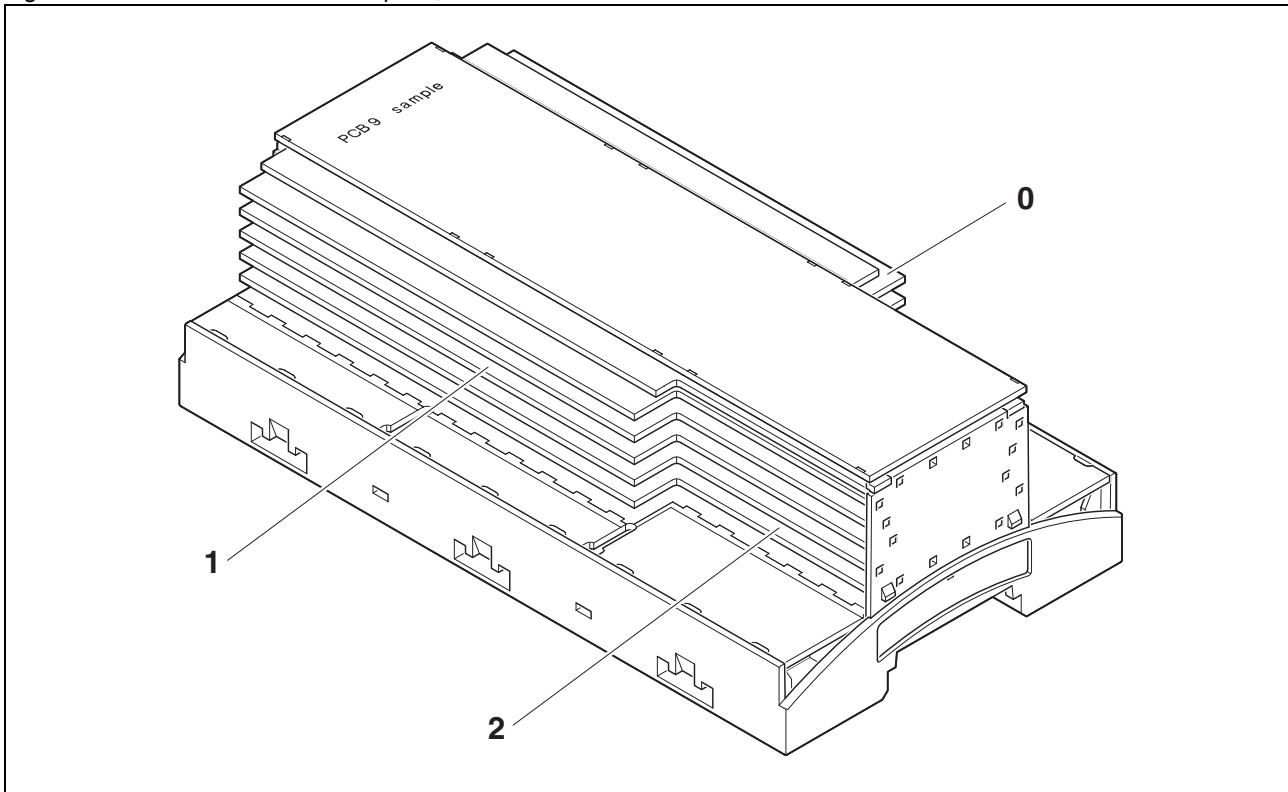

Version	Terminal installation depth
0	0 mm
1	11 mm
2	22 mm

### 9.3 Circuit board dimensions for PCB 1, horizontal

An overview of the arrangement of the horizontal circuit boards PCB 1 – 9 can be found on [page 32](#).

Figure 44 Upper side – mounting side of BC modular 161,6 (example BC 161,6 OT 010122)

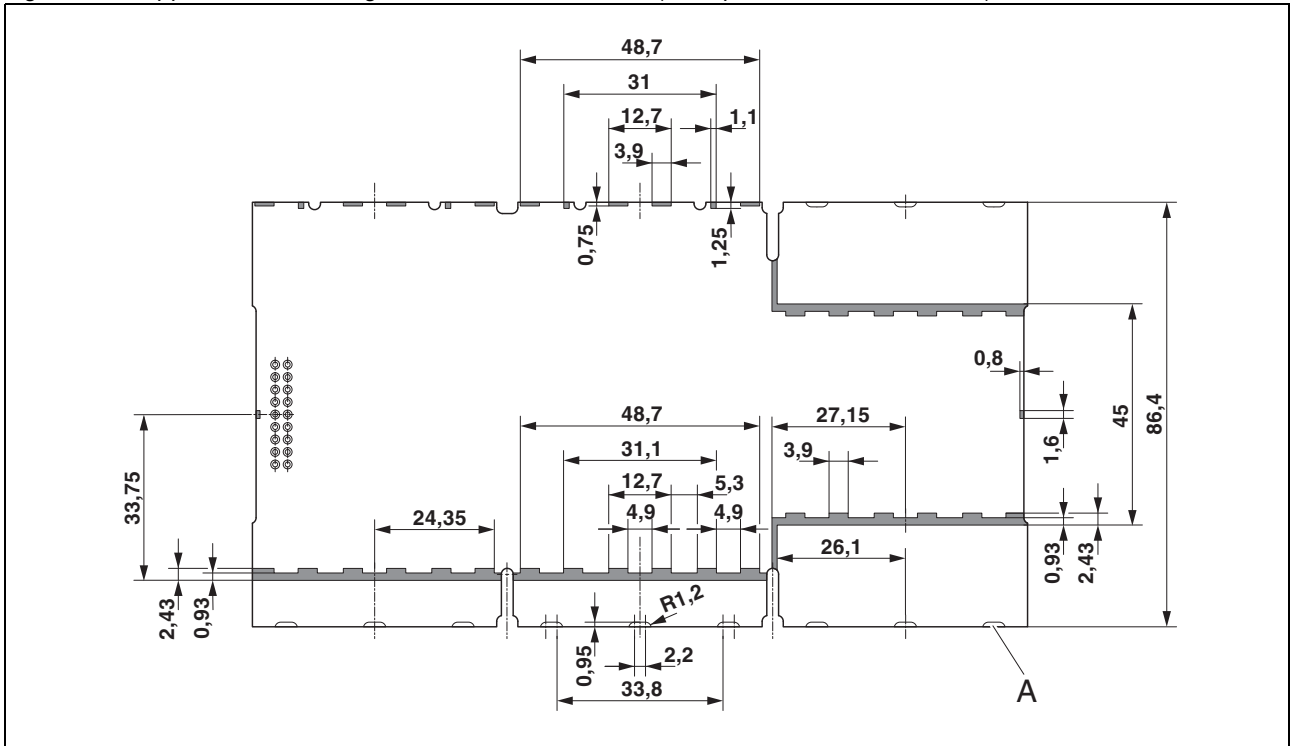



<b>A</b>	Contour for filler plug
<b>PCB thickness</b>	Maximum 1.8 mm
	Locked area, no components at these positions
Surface of the main PCB approx. 13000 mm <sup>2</sup> (mounting side)	

Figure 45 Lower side – soldering side of BC modular 161,6 (example BC 161,6 OT 010122)

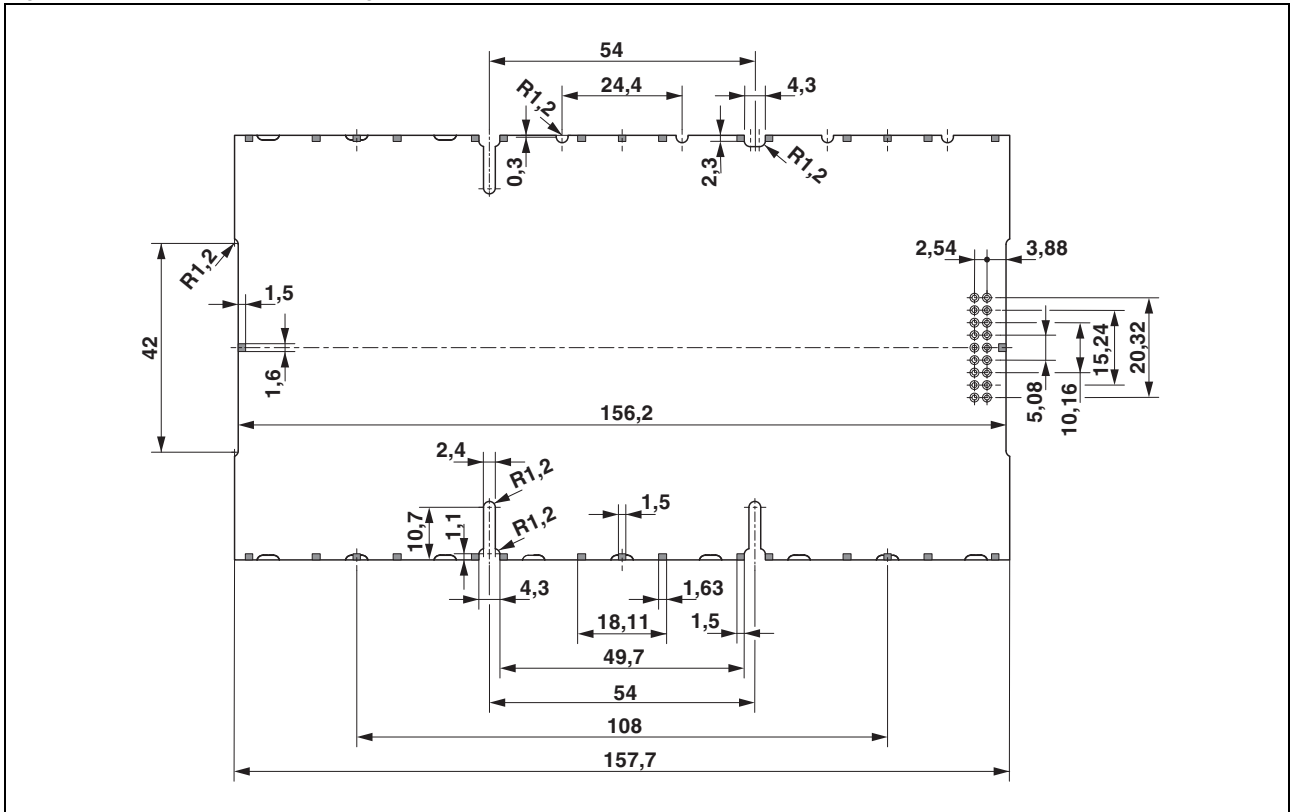

**PCB thickness** Maximum 1.8 mm

 Locked area, no components at these positions

#### 9.4 Circuit board dimensions for PCB 2 to 8, horizontal

An overview of the arrangement of the horizontal circuit boards PCB 1 – 9 can be found on [page 32](#).

Figure 46 Dimensions of PCB 2  
(example BC 161,6 OT 010122)

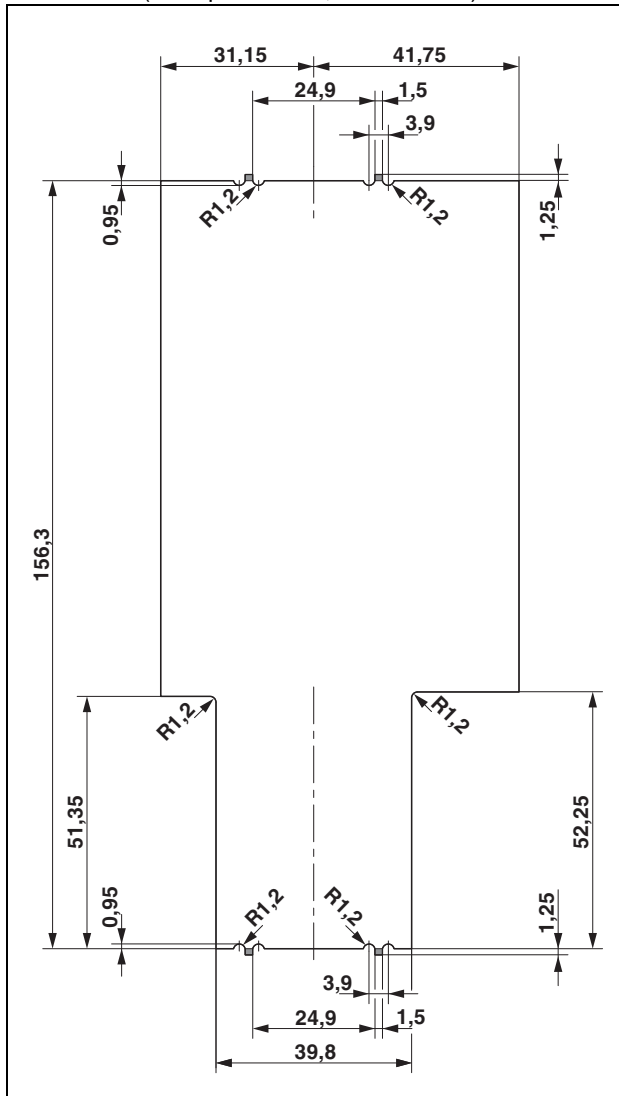

Figure 47 Dimensions of PCB 3  
(example BC 161,6 OT 010122)

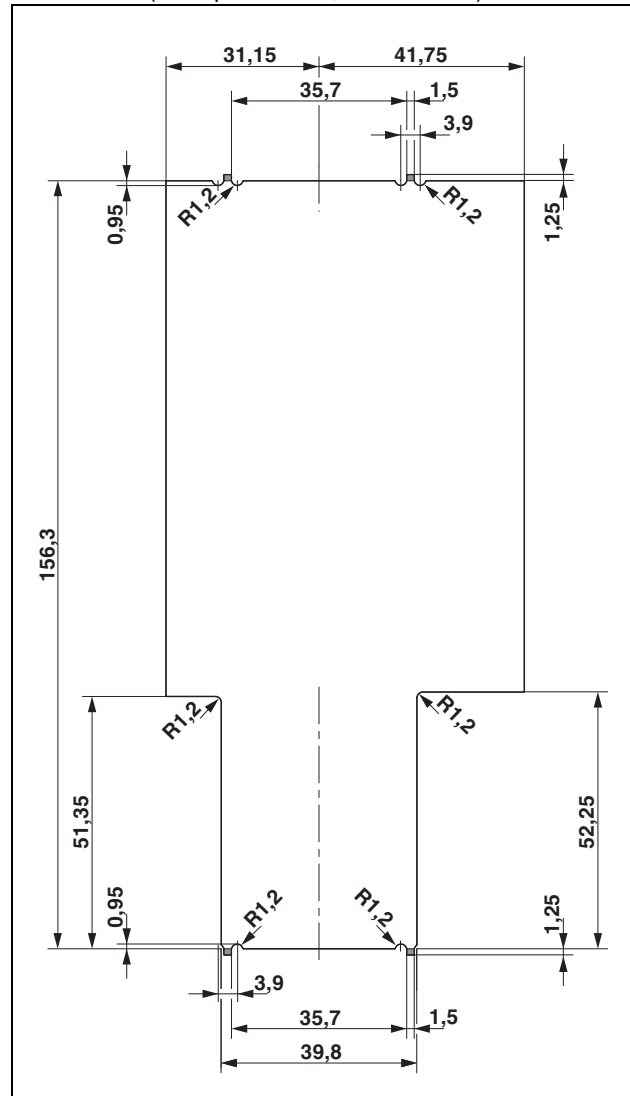

Figure 48 Dimensions of PCB 4  
(example BC 161,6 OT 010122)

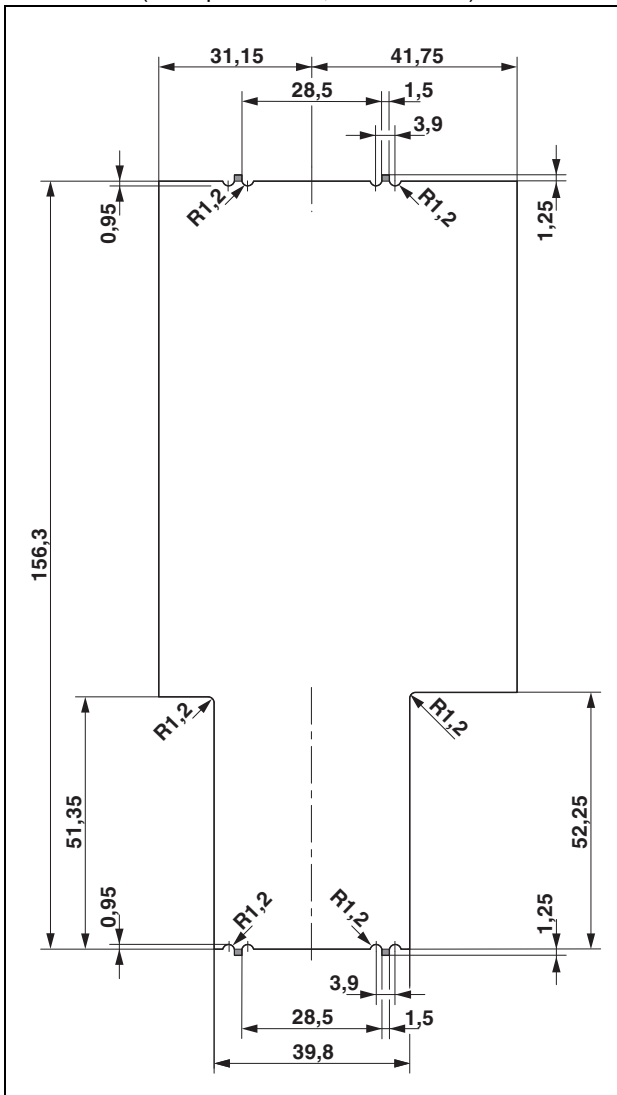

Figure 49 Dimensions of PCB 5  
(example BC 161,6 OT 010122)

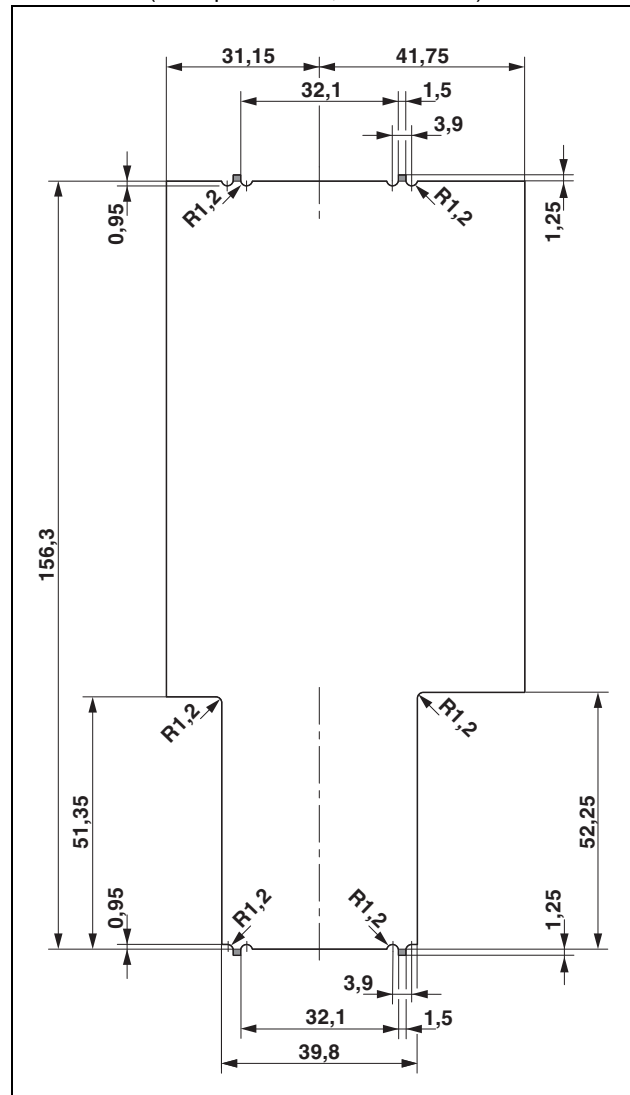

Figure 50 Dimensions of PCB 6  
(example BC 161,6 OT 010122)

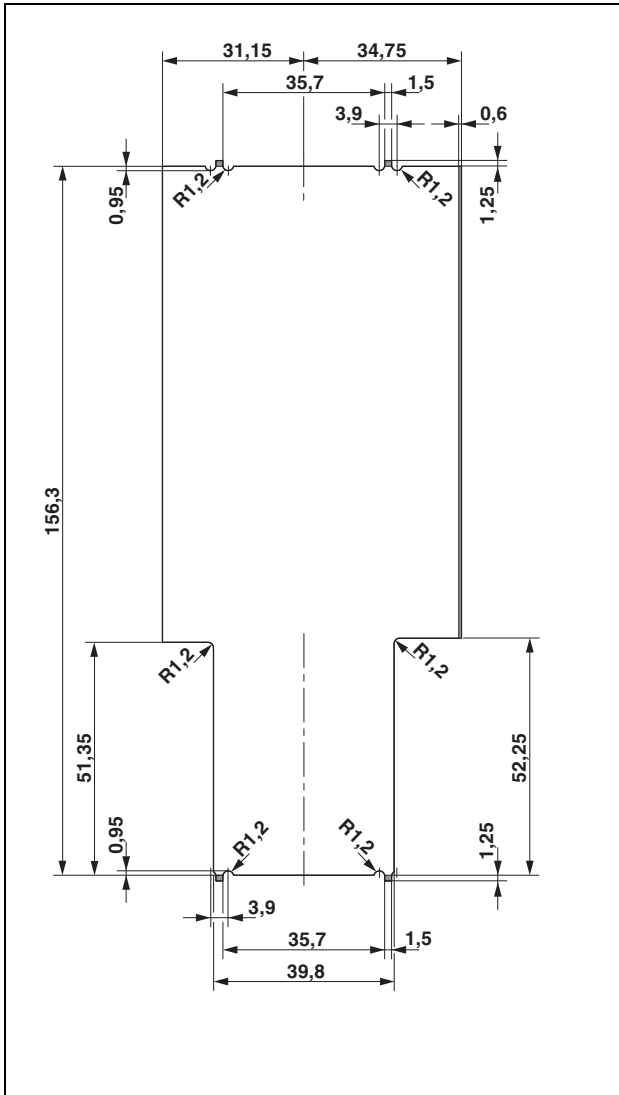

Figure 51 Dimensions of PCB 7  
(example BC 161,6 OT 010122)

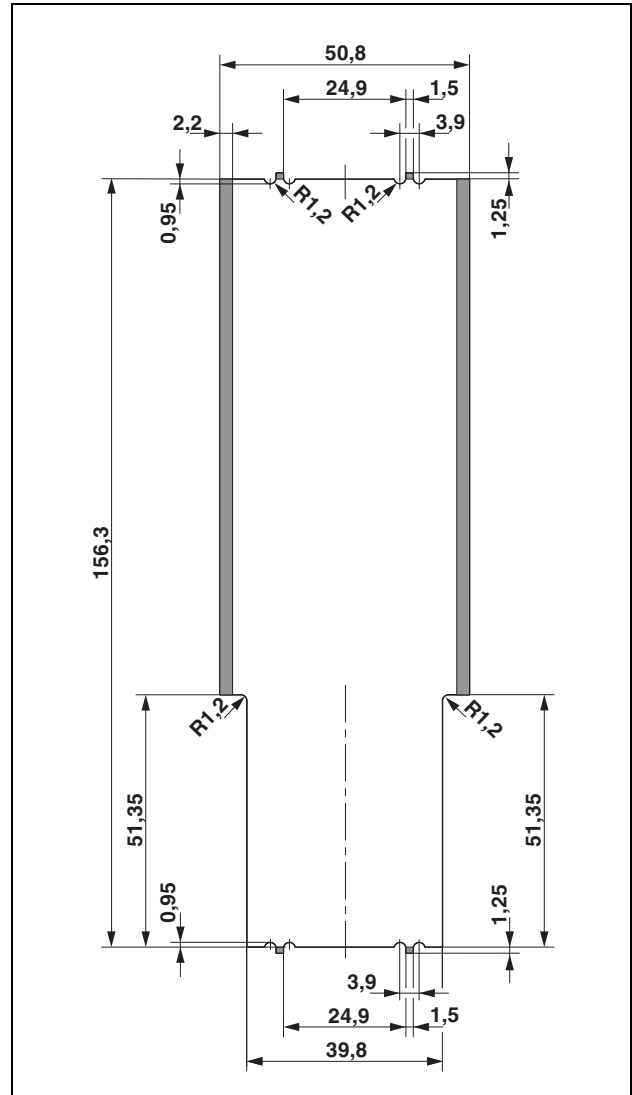
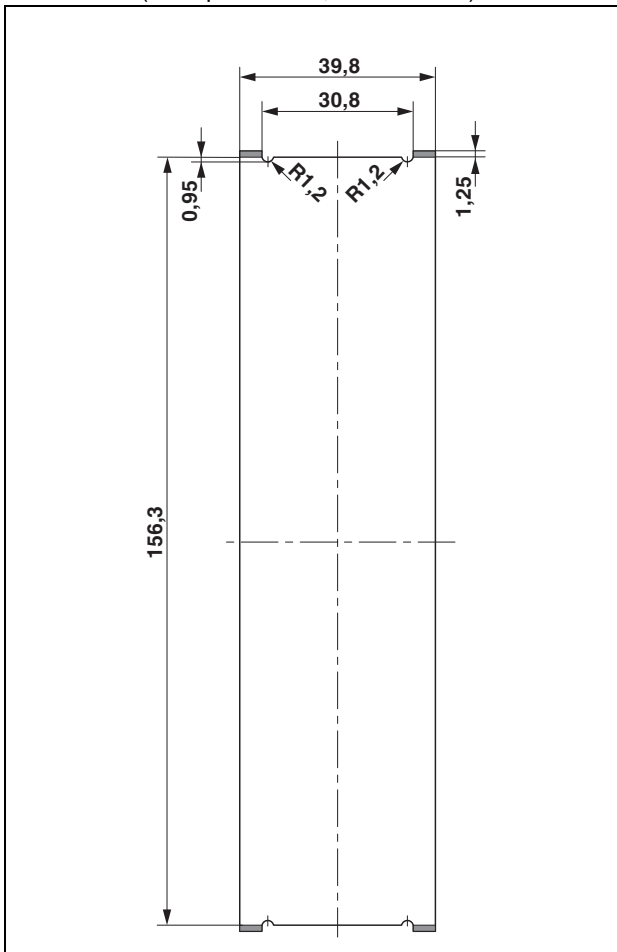

Figure 52 Dimensions of PCB 8  
(example BC 161,6 OT 010122)



### 9.5 Circuit board dimensions for PCB 9, horizontal

An overview of the arrangement of the horizontal circuit boards PCB 1 – 9 can be found on [page 32](#).

Figure 53 Dimensions of PCB 9 (BC 161,6)

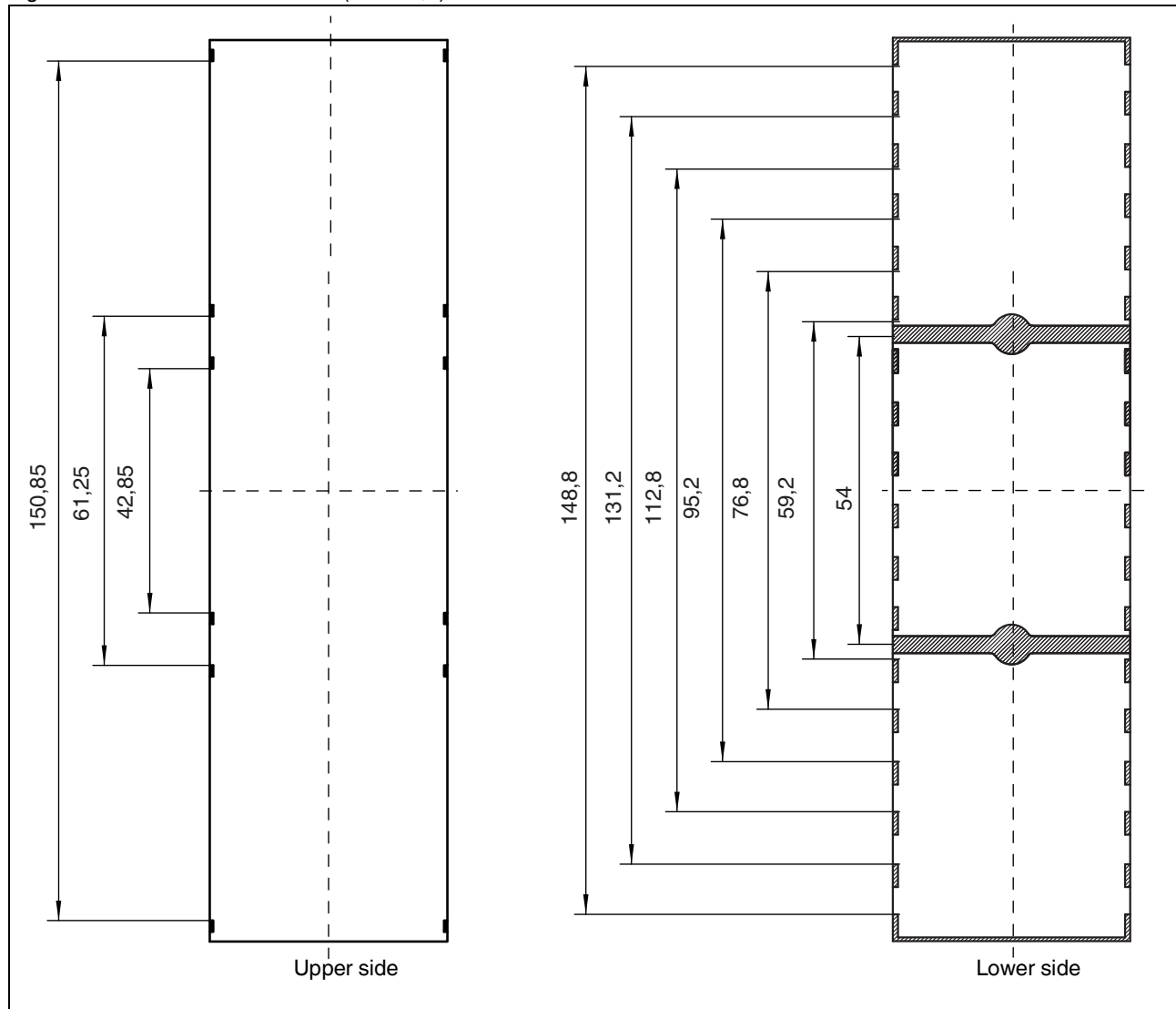

**PCB thickness** Maximum 1.8 mm  
 Locked area, no components at these positions

## 9.6 Perpendicular PCBs (BC 161,6 modular)

### PCBs transverse to the DIN rail

Figure 54 Terminal installation depth 0, 1 and 2 (example BC 161,6 OT 010122)

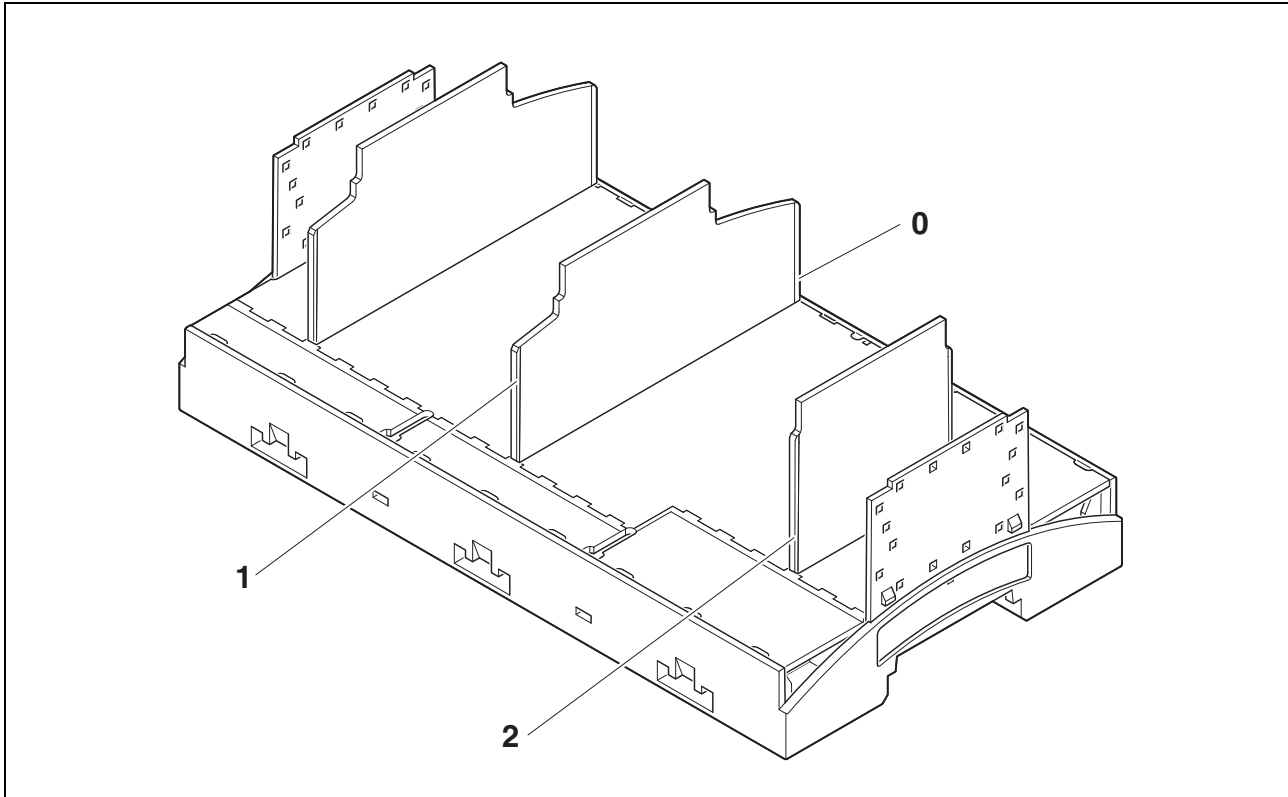

Version	Terminal installation depth
0	0 mm
1	11 mm
2	22 mm





Figure 57 Terminal installation depth 22 mm

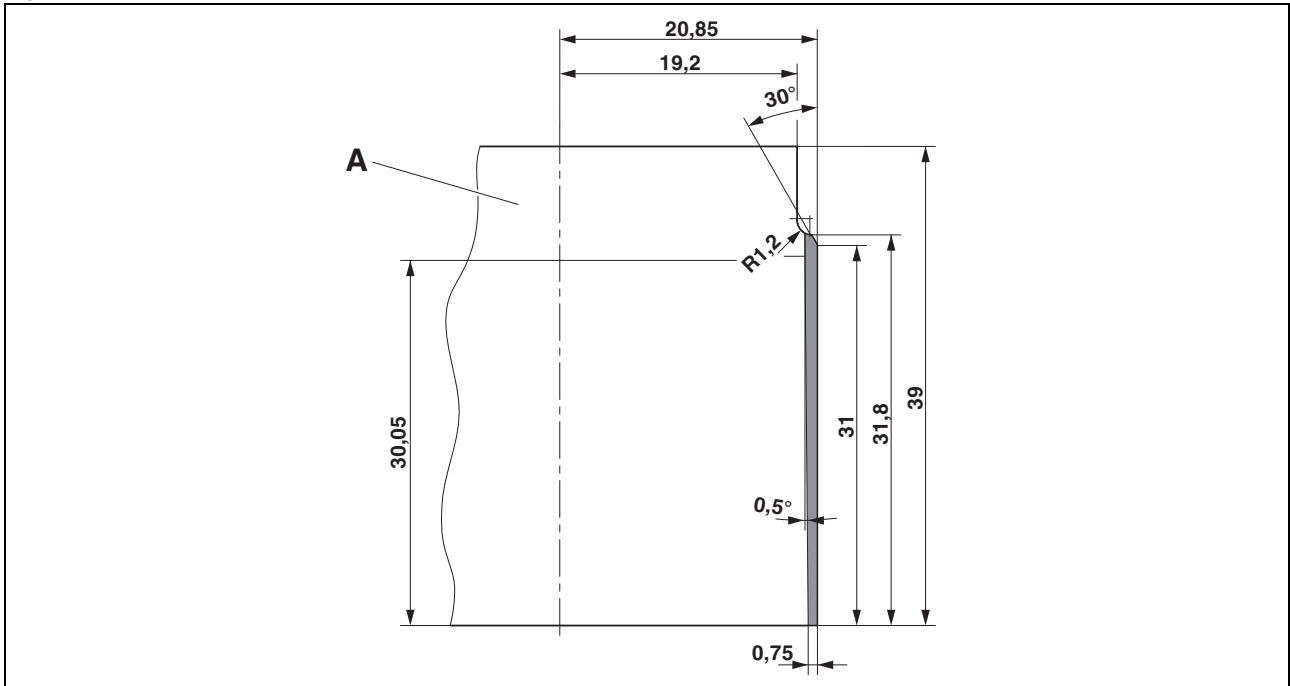

<b>PCB thickness</b>	Maximum 1.8 mm
	Locked area, no components at these positions
<b>A</b>	PCB surface, when no fitted cover is used

Figure 58 Cross-sectional view of perpendicular PCBs, transverse to the DIN rail



## 10 DIN rail connector with 1 slot (2TE – 9TE)

### 10.1 Circuit diagram of DIN rail connector

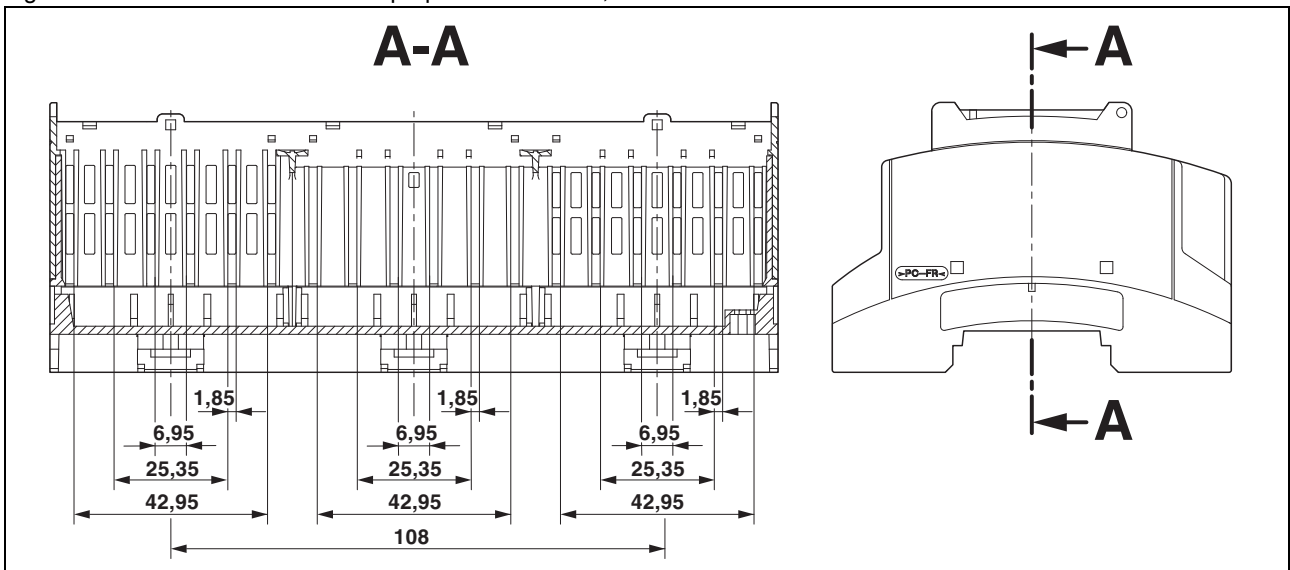
Figure 59 Circuit diagram HBUS...-16P-1S BK

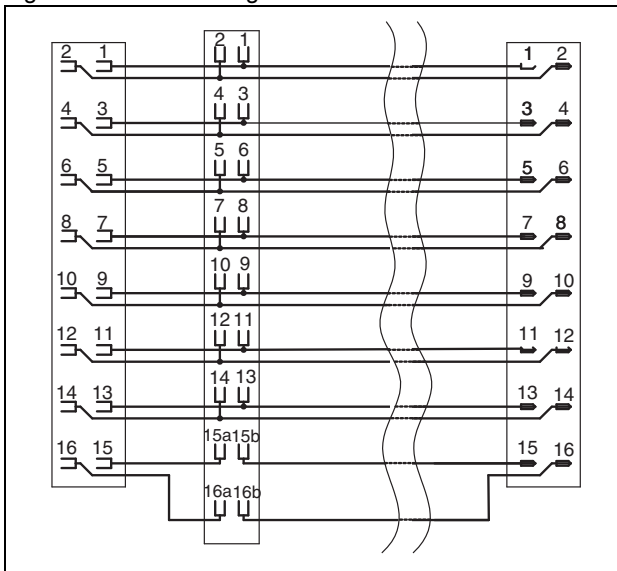

#### Contacts

Contact 1 ... 4 Power  
Contact 5 ... 16 Signal

#### Air and creepage distances

... to the DIN rail min. 0.23 mm  
... between one another min. 0.13 mm  
... between power and signal min. 0.8 mm

#### Current carrying capacity for each contact

3 A, maximum total current 25 A

### 10.2 Dimensional drawing of connector for DIN rail connector

Figure 60 Dimensional drawing of connector on perpendicular PCB (all except for BC 17,8) for contacting in the DIN rail connector

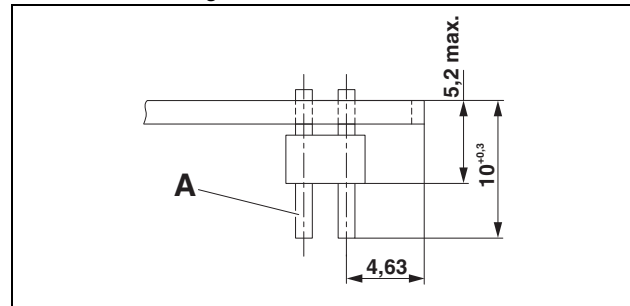

- A** Pin strip, max. 2 x 9-pos.  
□ 0.63 x 0.63 mm or ø 0.7 ... 0.8 mm  
2.54 mm pitch  
Gold-plated surface

### 10.3 Safety notes

Do not connect or disconnect the DIN rail connector under load.

Protect unused terminal points with a cover cap set (HBUS-B SET BK, 2278173).

### 10.4 Derating

Figure 61 Derating

