

# CAPAROC: System and installation

User manual

# User manual

## CAPAROC: System and installation

UM EN CAPAROC, Revision 00

2020-11-06

---

This user manual is valid for:

All modules of the CAPAROC system.

109745\_en\_00

# Table of contents

1	For your safety .....	5
1.1	Identification of warning notes .....	5
1.2	Qualification of users .....	5
1.3	Field of application of the product.....	6
1.3.1	Intended use .....	6
1.3.2	Product changes .....	6
1.4	Available documents .....	6
1.4.1	Documentation on the Internet .....	6
2	The CAPAROC product family .....	7
2.1	CAPAROC, the modular system.....	7
2.2	Structure of the CAPAROC system .....	8
2.3	Approvals .....	9
2.4	Overview of the CAPAROC modules.....	10
2.4.1	CAPAROC power modules .....	10
2.4.2	CAPAROC circuit breaker modules .....	11
2.4.3	CAPAROC Current-Rails .....	12
2.4.4	Housing versions, design, and dimensions .....	13
3	Transport and unpacking .....	21
3.1	Transport.....	21
3.2	Storage.....	21
3.3	Unpacking .....	21
4	Mounting and removing modules .....	23
4.1	Safety notes for mounting and removal .....	23
4.2	Basic information about mounting .....	24
4.3	Mounting the modules .....	25
4.4	Removing the modules.....	26
4.5	Replacing a module.....	26
4.6	Mounting distances .....	27
5	Connecting or removing cables .....	29
5.1	Connecting cables.....	29
5.2	Connecting the power supply .....	29
5.2.1	Requirements for the power supply .....	29
5.2.2	Connecting the power supply .....	30
5.3	Removing cables.....	30

6	Startup .....	31
6.1	Setting the nominal current.....	31
6.1.1	Programming (1- and 4-channel circuit breakers) .....	31
6.1.2	Programming (2-channel circuit breakers) .....	32
6.2	Connecting loads.....	34
6.3	Diagnostic and status indicators .....	34
6.3.1	Indicators on the power module .....	34
6.3.2	Indicators on the protective device .....	35
7	Process, parameter, and diagnostic data .....	37
7.1	Process data .....	37
7.1.1	Input process data slot 0/subslot 2 (global system data) .....	37
7.1.2	Output process data slot 0/subslot 2 (global system data) .....	38
7.1.3	Input process data of CAPAROC E2 12-24DC/2-10A .....	39
7.1.4	Output process data of CAPAROC E2 12-24DC/2-10A .....	40
7.2	Parameter and diagnostic data (PDI channel) .....	41
7.2.1	Parameters and acyclic data slot 0/subslot 2 (global system data) .....	41
7.2.2	Parameters and acyclic data slot 1 ...16 (CAPAROC E2 12-24V/2-10A) .....	43
8	After use .....	45
8.1	Device replacement.....	45
8.2	Device defect and repairs.....	45
8.3	Maintenance.....	45
8.4	Decommissioning and disposal.....	46
A	Appendix for document lists.....	47
A 1	List of figures .....	47
A 2	List of tables .....	49

# 1 For your safety

Read this user manual carefully and keep it for future reference.

## 1.1 Identification of warning notes



This symbol indicates hazards that could lead to personal injury.

There are three signal words indicating the severity of a potential injury.

### **DANGER**

Indicates a hazard with a high risk level. If this hazardous situation is not avoided, it will result in death or serious injury.

### **WARNING**

Indicates a hazard with a medium risk level. If this hazardous situation is not avoided, it could result in death or serious injury.

### **CAUTION**

Indicates a hazard with a low risk level. If this hazardous situation is not avoided, it could result in minor or moderate injury.



This symbol together with the **NOTE** signal word warns the reader of actions that might cause property damage or a malfunction.



Here you will find additional information or detailed sources of information.

## 1.2 Qualification of users

The use of products described in this user manual is oriented exclusively to:

- Electrically skilled persons or persons instructed by them. The users must be familiar with the relevant safety concepts of automation technology as well as applicable standards and other regulations.
- Qualified application programmers and software engineers. The users must be familiar with the relevant safety concepts of automation technology as well as applicable standards and other regulations.

## 1.3 Field of application of the product

### 1.3.1 Intended use

CAPAROC is a modular device circuit breaker system. The devices correspond to protection class IP20. They are intended for use in closed control cabinets or control boxes (junction boxes) with IP54 degree of protection or higher.

The devices are designed for use in industrial environments.

### 1.3.2 Product changes

Modifications to hardware and firmware of the device are not permitted.

Incorrect operation or modifications to the device can endanger your safety or damage the device. Do not repair the device yourself. If the device is defective, please contact Phoenix Contact.

## 1.4 Available documents

Table 1-1 Available documents

Document	Contents
User manual	This user manual is the generic system manual for CAPAROC. It describes the CAPAROC product group and everything about mounting, removal, and wiring of CAPAROC modules.
Installation note	The installation note is included with every power module and is available to download via the website.

### 1.4.1 Documentation on the Internet

The documentation can be downloaded at [phoenixcontact.net/products](http://phoenixcontact.net/products). Here you will find information on each product. You can obtain a summary of the technical data by selecting "Generate product PDF"; other important documents can be found on the "Downloads" tab.

#### Generate product PDF

Click the "Generate product PDF" button to receive selected up-to-date information. This provides a brief overview of the module. The generated PDF file contains the essential product information. If you require further information, you can use the "Downloads" tab.

#### Downloads

On the "Downloads" tab, you can access the complete documentation and all other downloads related to a product. Module-specific documentation can be found in the download area for the corresponding module.

## 2 The CAPAROC product family

### 2.1 CAPAROC, the modular system

CAPAROC is an electronic circuit breaker system for use in control cabinets. Simply extend the system via the rear Current-Rail.

#### Your advantages

- The customizable standard, thanks to a wide range of possible combinations of the future-proof modular system
- Easy operation for everyone through tool-free assembly, uninterrupted installation, and transparent operating state
- Strikingly simple design-in with extensive support from the selection up to digital services

## 2.2 Structure of the CAPAROC system

A CAPAROC system consists of individual modules, which are snapped onto a DIN rail via a Current-Rail.

The power module forms the head of the station. The circuit breaker modules are connected to the right of it.

The connection between the power module and the individual CAPAROC modules is established via the side bus connectors. The internal CAPAROC bus is formed automatically when the various CAPAROC modules are snapped on.

Figure 2-1 Example of a CAPAROC system

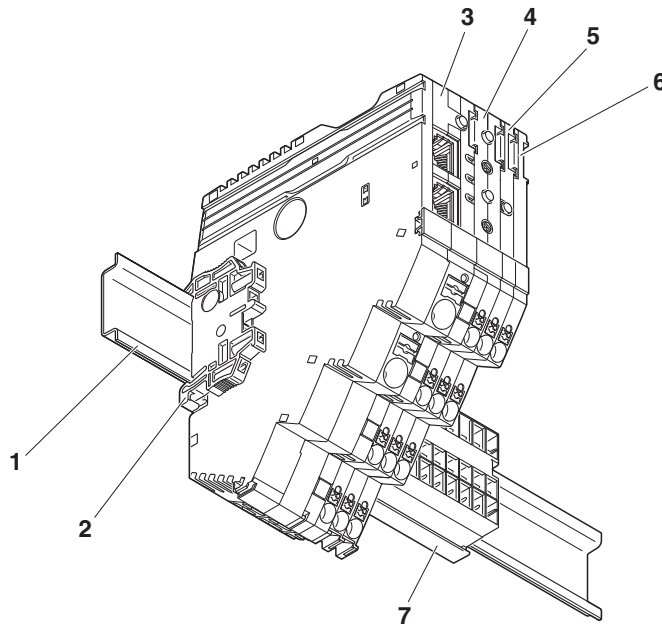

- 1 DIN rail
- 2 End bracket
- 3 Power module
- 4 2-channel 2 - 10 A circuit breaker
- 5 1-channel 1 - 10 A circuit breaker
- 6 Potential distributor module
- 7 Current-Rail

## 2.3 Approvals

For the latest approvals for a product, please visit [phoenixcontact.net/products](https://phoenixcontact.net/products).

- Go to the page for the relevant product.
- Switch to the “Approvals” tab.

The current approvals for the product are listed.



Observe any notes and restrictions for the approvals in the module-specific packing slip or in the module-specific documentation.

## 2.4 Overview of the CAPAROC modules

### 2.4.1 CAPAROC power modules

Figure 2-2 PM PN and PM S-R power modules

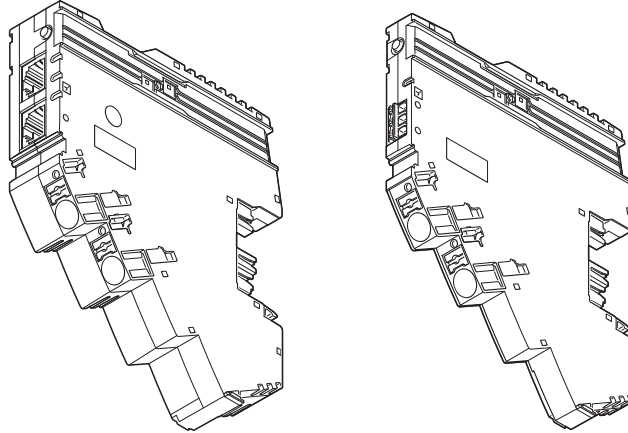
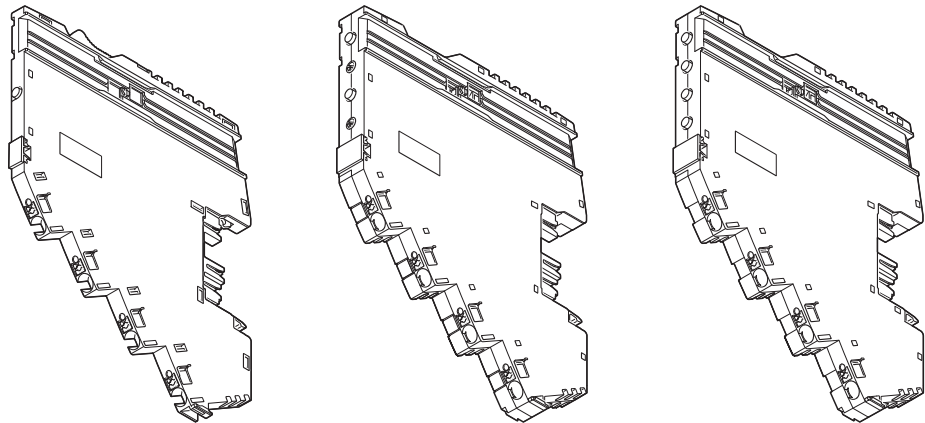

Table 2-1 Overview of power modules

Designation	Order No.	Description
CAPAROC PM S-R	1115661	power module status-reset for supplying the system with the required voltage. Query system messages via a group message from the module. A reset input and an I>80% signal output provide additional diagnostics and reset options.
CAPAROC PM PN	1110986	power module for supplying the system with the required voltage and PROFINET interface. The system provides extended diagnostics and control options via the integrated interface.

## 2.4.2 CAPAROC circuit breaker modules

Figure 2-3 Example: 1-channel, 2-channel, and 4-channel circuit breaker modules



### Adjustable circuit breaker modules

Table 2-2 Overview of adjustable circuit breaker modules

Designation	Order No.	Description
1-channel electronic circuit breakers		
CAPAROC E1 12-24DC/1-4A	1115415	Adjustable from 1 - 4 A
CAPAROC E1 12-24DC/1-10A	1115649	Adjustable from 1 - 10 A
2-channel electronic circuit breakers		
CAPAROC E2 12-24DC/1-4A	1115655	Adjustable from 1 - 4 A
CAPAROC E2 12-24DC/2-10A	1110984	Adjustable from 2 - 10 A
4-channel electronic circuit breakers		
CAPAROC E4 12-24DC/1-4A	1115657	Adjustable from 1 - 4 A
CAPAROC E4 12-24DC/1-10A	1115658	Adjustable from 1 - 10 A

### Non-adjustable circuit breaker modules (fixed values)

Table 2-3 Overview of non-adjustable circuit breaker modules (fixed values)

Designation	Order No.	Description
1-channel electronic circuit breakers		
CAPAROC E1 12-24DC/1A	1157288	1 A nominal current
CAPAROC E1 12-24DC/2A	1157290	2 A nominal current
CAPAROC E1 12-24DC/4A	1157285	4 A nominal current
CAPAROC E1 12-24DC/6A	1157286	6 A nominal current
CAPAROC E1 12-24DC/8A	1157279	8 A nominal current
CAPAROC E1 12-24DC/10A	1157284	10 A nominal current

### 2.4.3 CAPAROC Current-Rails

Figure 2-4 Example: CR 20 and CR EXT8 Current-Rail

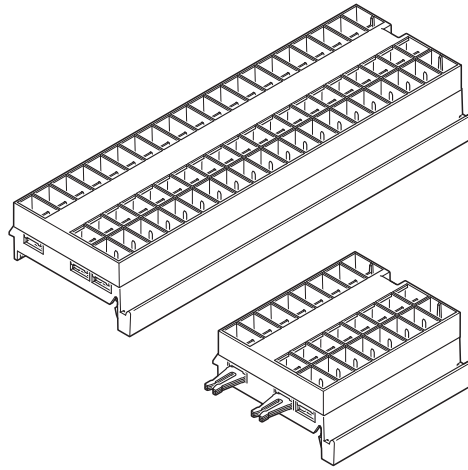

Table 2-4 Overview of Current-Rails

Designation	Order No.	Description
Basic Current-Rails		
CAPAROC CR 8	1115672	Rear Current-Rail for distributing the supply voltage with an overall width of 8 HP (49.2 mm).
CAPAROC CR 20	1110989	Rear Current-Rail for distributing the supply voltage with an overall width of 20 HP (123 mm).
Extension Current-Rails		
CAPAROC CR EXT4	1110991	Rear Current-Rail for extending the system and distributing the supply voltage with an overall width of 4 HP (24.6 mm).
CAPAROC CR EXT8	1110990	Rear Current-Rail for extending the system and distributing the supply voltage with an overall width of 8 HP (49.2 mm).
CAPAROC CR EXT20	1115674	Rear Current-Rail for extending the system and distributing the supply voltage with an overall width of 20 HP (123 mm).

## 2.4.4 Housing versions, design, and dimensions

Figure 2-5 Housing versions

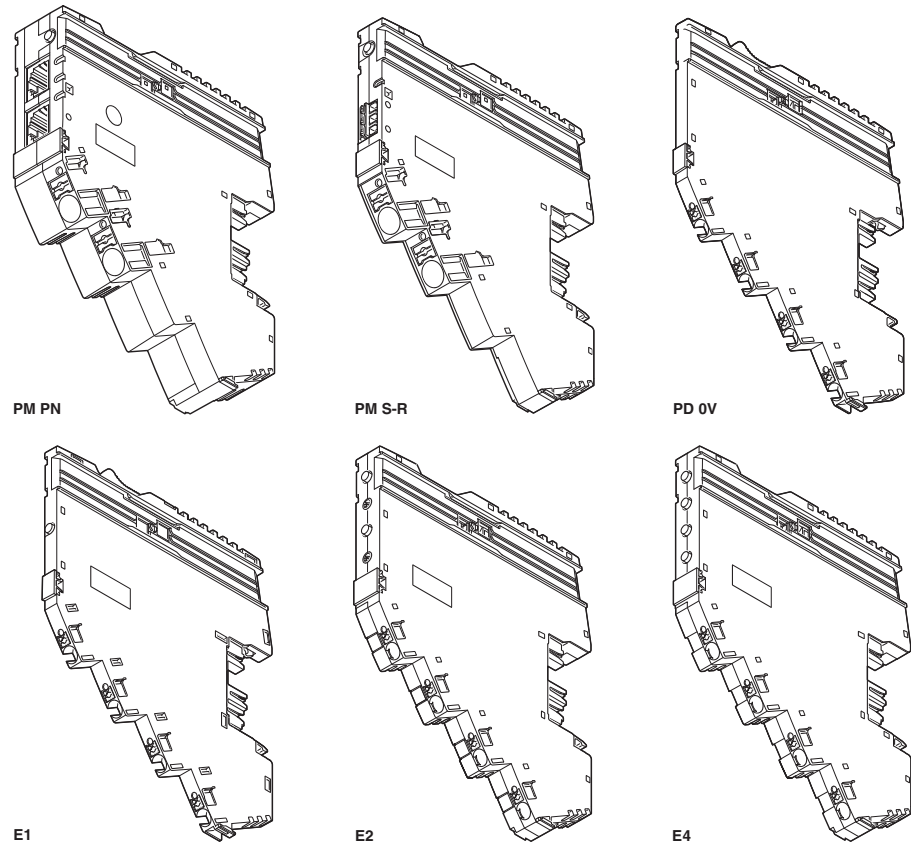
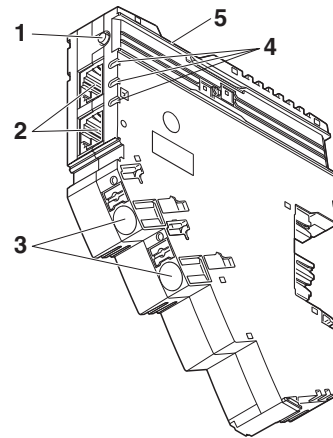

Table 2-5 Overview of housing versions

Housing type	Special feature	Example	Design	Dimensions
PM PN	power module with PROFINET	CAPAROC PM PN	<a href="#">Figure 2-6 on page 14</a>	<a href="#">Figure 2-7 on page 14</a>
PM S-R	power module with status-reset	CAPAROC PM S-R	<a href="#">Figure 2-8 on page 15</a>	-
E1	1-channel circuit breaker	CAPAROC E1 12-24DC/1-10A	<a href="#">Figure 2-9 on page 16</a>	<a href="#">Figure 2-10 on page 16</a>
E2	2-channel circuit breaker	CAPAROC E2 12-24DC/2-10A	<a href="#">Figure 2-11 on page 17</a>	<a href="#">Figure 2-12 on page 17</a>
E4	4-channel circuit breaker	CAPAROC E4 12-24DC/1-10A	<a href="#">Figure 2-13 on page 18</a>	<a href="#">Figure 2-14 on page 18</a>
PD 0V	0 V potential distributor	CAPAROC PD 0V	<a href="#">Figure 2-15 on page 19</a>	<a href="#">Figure 2-16 on page 19</a>

**CAPAROC PM PN power module**

Figure 2-6 Design of CAPAROC PM PN



- |   |                  |   |                 |
|---|------------------|---|-----------------|
| 1 | Power LED (PWR)  | 4 | Diagnostic-LEDs |
| 2 | RJ45 connections | 5 | Release         |
| 3 | Feed-in IN+, IN- |   |                 |

Figure 2-7 Dimensional drawing of CAPAROC PM PN

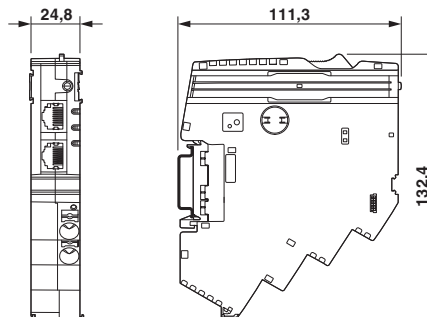

**CAPAROC PM S-R power module**

Figure 2-8 Design of CAPAROC PM S-R

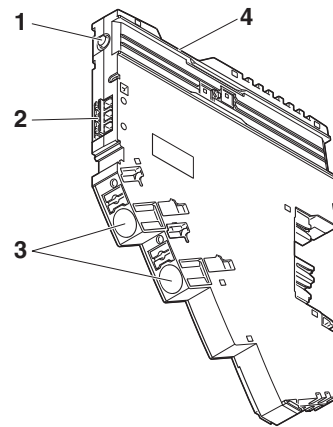

- |   |                    |   |                  |
|---|--------------------|---|------------------|
| 1 | Power LED (PWR)    | 3 | Feed-in IN+, IN- |
| 2 | Signal connections | 4 | Release          |

**CAPAROC E1 ... circuit breaker**

Figure 2-9 Design of CAPAROC E1 ...

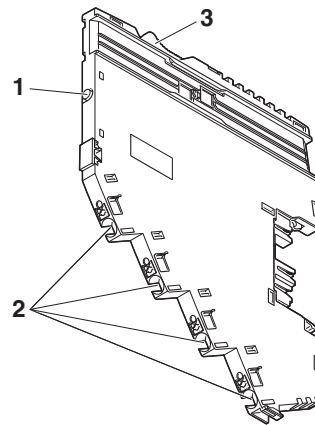

- |   |                       |   |         |
|---|-----------------------|---|---------|
| 1 | LED button channel 1  | 3 | Release |
| 2 | Load output channel 1 |   |         |

Figure 2-10 Dimensional drawing of CAPAROC E1 ...

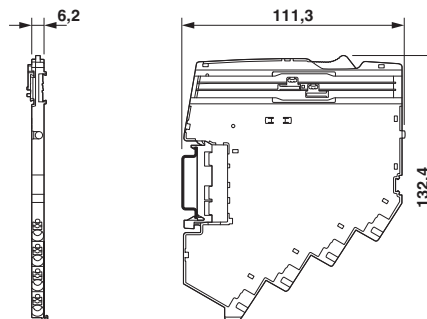

**CAPAROC E2 ... circuit breaker**

Figure 2-11 Design of CAPAROC E2 ...

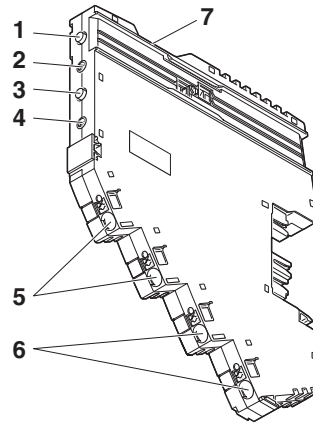

- |   |                         |   |                       |
|---|-------------------------|---|-----------------------|
| 1 | LED button channel 1    | 5 | Load output channel 1 |
| 2 | Rotary switch channel 1 | 6 | Load output channel 2 |
| 3 | LED button channel 2    | 7 | Release               |
| 4 | Rotary switch channel 2 |   |                       |

Figure 2-12 Dimensional drawing of CAPAROC E2 ...

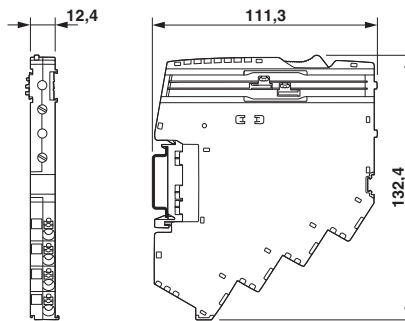

**CAPAROC E4 ... circuit breaker**

Figure 2-13 Design of CAPAROC E4 ...

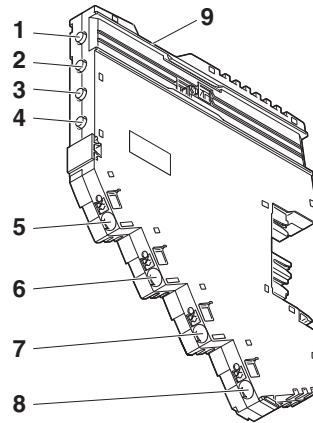

- |   |                       |   |                       |
|---|-----------------------|---|-----------------------|
| 1 | LED button channel 1  | 6 | Load output channel 2 |
| 2 | LED button channel 2  | 7 | Load output channel 3 |
| 3 | LED button channel 3  | 8 | Load output channel 4 |
| 4 | LED button channel 4  | 9 | Release               |
| 5 | Load output channel 1 |   |                       |

Figure 2-14 Dimensional drawing of CAPAROC E4 ...

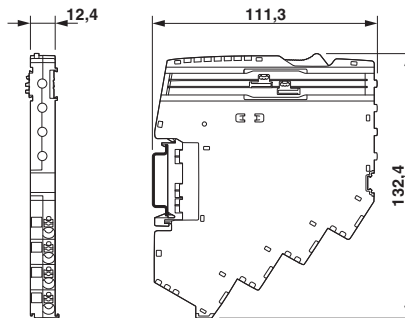

**CAPAROC PD 0V potential distributor**

Figure 2-15 Design of CAPAROC PD 0V

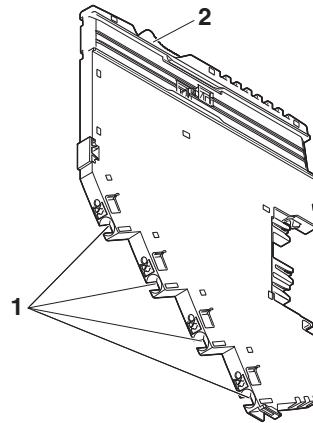

1 IN- potential distribution

2 Release

Figure 2-16 Dimensional drawing of CAPAROC PD 0V

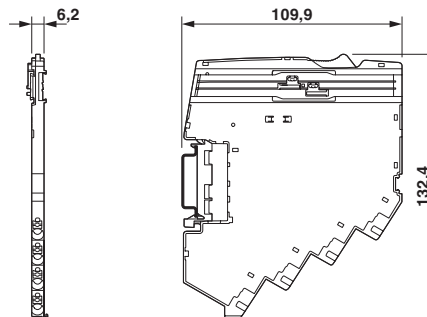



## 3 Transport and unpacking

### 3.1 Transport

**NOTE: Electrostatic discharge**

Electrostatic discharge can damage or destroy components. When handling the device, observe the necessary safety precautions against electrostatic discharge (ESD) in accordance with EN 61340-5-1 and IEC 61340-5-1.

**Suitable transport packaging**

- Only transport the device in its original packaging or in packaging suitable for transport.

**Technical data and environmental conditions**

- During transport, observe the specifications regarding humidity and the temperature range.

### 3.2 Storage

**Suitable storage location**

The storage location must meet the following requirements:

- Dry
- Protected from unauthorized access
- Protected from harmful environmental influences such as UV light

**Technical data and environmental conditions**

- During storage, observe the specifications regarding the temperature range, air pressure, and humidity.

### 3.3 Unpacking

**Observing the packing slip**

- Read the complete packing slip carefully before unpacking the device.
- Retain the packing slip.

**Checking the delivery**

- Check the delivery for damage and completeness.
- Submit claims for any transport damage immediately.



## 4 Mounting and removing modules

### 4.1 Safety notes for mounting and removal



**WARNING: Dangerous contact voltage**

Only qualified personnel may do this work. The personnel must be familiar with the necessary safety precautions.



**WARNING: Dangerous contact voltage in the event of ground faults**

– The CAPAROC modules for the low-voltage area must only be operated in grounded networks.



**NOTE: Electrostatic discharge**

The modules contain components that can be damaged or destroyed by electrostatic discharge. When handling the device, observe the necessary safety precautions against electrostatic discharge (ESD) in accordance with EN 61340-5-1 and IEC 61340-5-1.



**NOTE: Damage to the contacts when tilting**

Tilting the modules can damage the contacts.

- Place the modules onto the Current-Rail vertically.
- Remove the modules vertically from the Current-Rail.

Figure 4-1 Placing and removing the module vertically

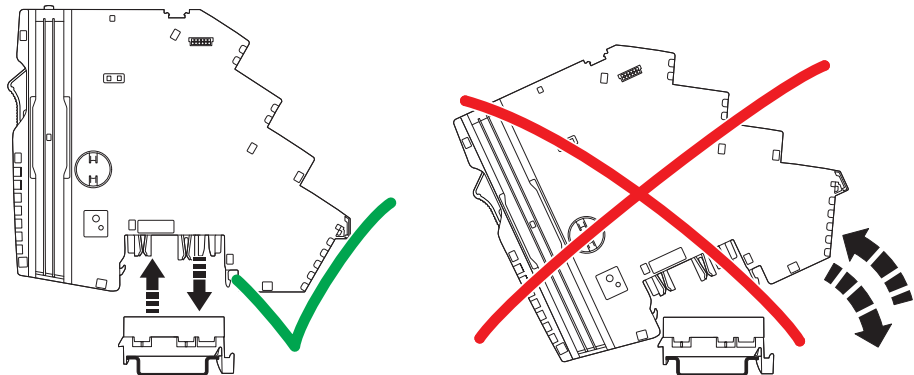

Additionally observe the information in the module-specific data sheets.

#### Qualified personnel

In terms of this user manual, qualified personnel are persons who, because of their education, experience and instruction, and their knowledge of relevant standards, regulations, accident prevention, and service conditions, have been authorized to carry out any required operations, and who are able to recognize and avoid any possible dangers. See [Section "Qualification of users" on page 5](#).

## 4.2 Basic information about mounting

- Mounting location** The CAPAROC modules meet the requirements of IP20 degree of protection. They are intended for use in closed control cabinets or control boxes (junction boxes) with IP54 degree of protection in accordance with EN 60529 or higher.
- DIN rail** Mount the CAPAROC modules on a 35 mm standard DIN rail. The preferred installed height of the DIN rail is 7.5 mm (corresponds to TH 35-7.5 in accordance with EN 60715).  
Mount the modules vertically on the DIN rail. As the module does not need to be tilted, easy installation and removal is ensured even in confined spaces.
- Mounting position** Wall mounting on a horizontal DIN rail on the wall is the preferred mounting position. This mounting position provides optimum air flow for the modules.
- End brackets** Mount end brackets on both sides of the CAPAROC modules. The end brackets ensure that the CAPAROC system is correctly mounted on the DIN rail. They secure it on both sides and keep it from moving from side to side on the DIN rail.  
Always attach the left end bracket of the system when beginning to mount the system. This ensures the following:
- It prevents the system from slipping on the DIN rail.
  - The space for the end bracket is secured.
  - When connecting additional modules and Current-Rails, the system does not slip on the DIN rail.
  - The side connection of the modules can be better secured. This ensures internal communication.
- Tools** No tools are required for mounting the modules.  
A standard tool, e.g., a bladed screwdriver with a blade width of 2.5 mm, is necessary for removing the Current-Rail and actuating the spring levers.
- Order of the modules** After the power module, the modules can be installed in any order on the DIN rail. To ensure functionality, mount the modules side by side, without a gap.
- To establish a connection to the internal bus system, mount the modules to the right of the power module.
  - Modules that are to the left of the power module have no connection to the internal bus system. They have no connection to the internal remote signaling and cannot be used for functions supported on the bus side.
- Maximum number of modules** The maximum number of CAPAROC circuit breaker modules depends on the power module used.  
For the maximum number, please refer to the table below and the relevant power module data sheet.

Table 4-1 Maximum number of circuit breaker modules

Power module	Description	Max. number
CAPAROC PM S-R	power module with status-reset	20 modules
CAPAROC PM PN	power module with PROFINET	16 modules

### 4.3 Mounting the modules

**i** Please refer to Section [“Safety notes for mounting and removal”](#) on page 23

No tools are required to mount the CAPAROC system.

- First, mount the end bracket on the DIN rail.

#### Mounting the Current-Rail

- First, install the Current-Rail on the DIN rail.
- Use an appropriately sized Current-Rail for the application.
- If one Current-Rail is not enough, you can extend it with an additional Current-Rail.
- To connect them, insert the next Current-Rail in the connection of the preceding one.

**i** Current-Rails are available with different overall widths. Select the appropriate length for your application from the overview in [Section “CAPAROC Current-Rails”](#) on page 12.

#### Snapping on the modules

Place the power module and circuit breaker modules onto the Current-Rail and DIN rail vertically until they snap into place. Make sure that the device plugs for the Current-Rail are positioned above the corresponding opening on the Current-Rail. Use the guide slots on the housing sides to connect the modules together.

Figure 4-2 Snapping on the modules

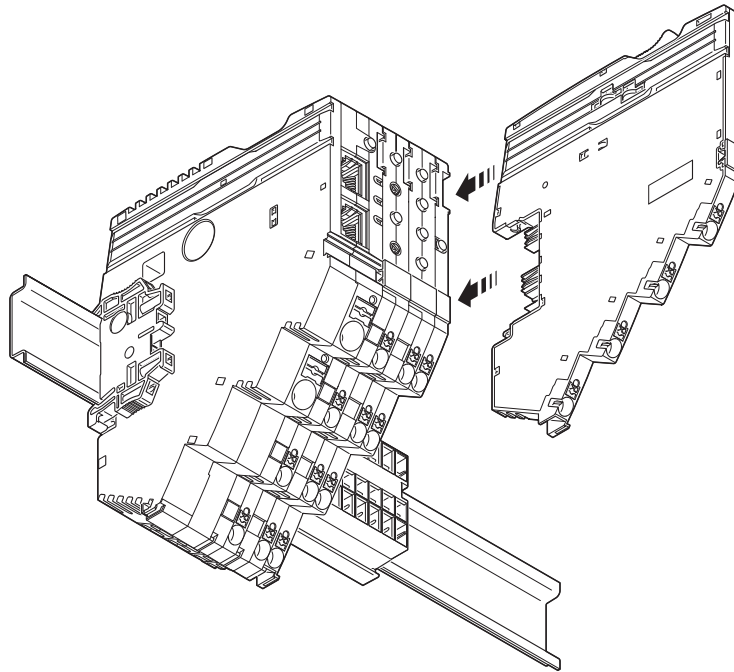

## 4.4 Removing the modules

 Please refer to Section [“Safety notes for mounting and removal”](#) on page 23

A standard tool, e.g., a bladed screwdriver with a blade width of 2.5 mm, is necessary for removing modules.

### Removing cables

See [Section 5.3, “Removing cables”](#)

### Removing the module

Actuate the release mechanism to remove the power module and the circuit breaker modules. This is located on the top of the modules (orange lever). You can then remove the modules vertically from the Current-Rail while the release mechanism is actuated.

### Removing the Current-Rail

To remove the Current-Rail from the DIN rail, use a screwdriver to release the latching via the slot on the side of the Current-Rail. Depending on the Current-Rail used, repeat this step several times from left to right. Then remove the Current-Rail from the DIN rail.

Figure 4-3 Removing the Current-Rail

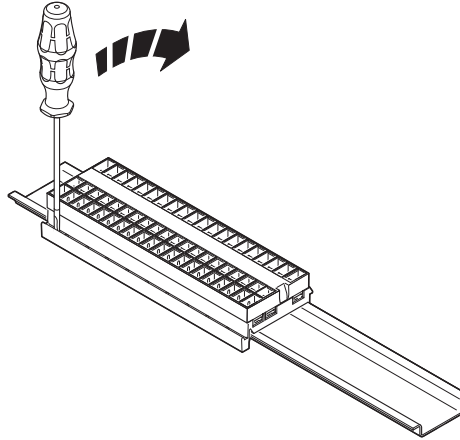

## 4.5 Replacing a module

- To replace a module, proceed as described in Sections [“Removing the modules”](#) on page 26 and [“Mounting the modules”](#) on page 25.
- Following replacement, make sure that all cables are connected correctly and securely again.

 Due to the rear Current-Rail, modules can also be replaced during operation. The load circuit of the other modules is not interrupted. Only the internal bus system is interrupted. After successfully mounting a new identical module, communication is automatically restored and the system does not need to be restarted.

## 4.6 Mounting distances



Leave enough space below the system to connect all the cables.

Maintain a minimum distance of 30 mm above and below to ensure adequate convection cooling.

Figure 4-4 Mounting distances for the CAPAROC system

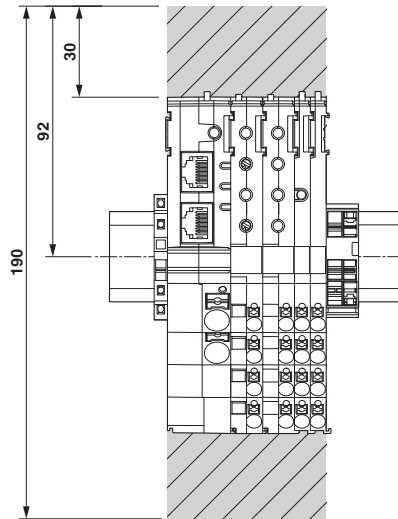



## 5 Connecting or removing cables

### 5.1 Connecting cables

All the connections of the CAPAROC system feature Push-in connection technology, enabling tool-free and above all fast and safe wiring.

Connect the network cable for the CAPAROC PM PN to the power module via an RJ45 connector.

Please observe the following during wiring:

- Make sure to install the conductor in the middle of the wiring space.

 If you are using ferrules, comply with the specifications described in the module-specific documentation. Make sure that the ferrules are crimped correctly.

### 5.2 Connecting the power supply

#### 5.2.1 Requirements for the power supply

Choose a power supply unit that is suitable for the currents in your application. The selection depends on the system configuration and the resulting maximum currents.

 **WARNING: Loss of electrical safety when using unsuitable power supplies. Dangerous shock currents.**

The CAPAROC system is designed exclusively for protective extra-low voltage (PELV) operation in accordance with EN 60204-1. Only protective extra-low voltage in accordance with the defined standard may be used for supply purposes.

- Only use power supply units that ensure safe isolation in accordance with EN 50178 and EN 64010-2-201. They prevent short circuits between the primary and secondary circuit.

 **WARNING: Dangerous contact voltage in the event of ground faults**  
– The CAPAROC modules for the low-voltage area must only be operated in grounded networks.

### 5.2.2 Connecting the power supply

The power supply is connected to the CAPAROC system via connections IN+ 1.1 and IN- 2.1 of the power module.

The other modules are also automatically supplied with power via the rear Current-Rail.

Figure 5-1 Connecting the CAPAROC power supply

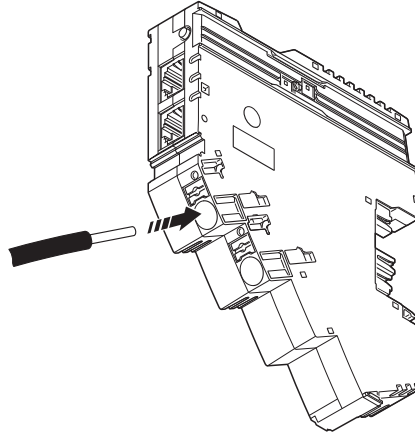

### 5.3 Removing cables

- To remove a cable from the terminal point, press on the spring lever using a suitable tool (e.g., bladed screwdriver with a blade width of 2.5 mm). This opens the leg-spring connection of the relevant terminal point.
- Remove the conductor.

## 6 Startup

### 6.1 Setting the nominal current

Determine the nominal current of the load prior to startup. Set this for the relevant channel.

For the 1- and 4-channel circuit breakers the nominal current is set (programmed) via LED button; for the 2-channel circuit breakers it is set via rotary switch.



Note:

- All channels are switched off by default.
- The channel can be switched on and off via the channel LED button.
- The previous channel states are restored when the device is switched on.
- The channels in the system start cascaded with a standard delay of 50 ms.

#### 6.1.1 Programming (1- and 4-channel circuit breakers)

It is only possible to program adjustable circuit breakers (designation in the name, e.g., 1-10A).

- Start the programming mode by pressing the LED button (>2 seconds). The LED shows the nominal current set via a yellow flashing rhythm (e.g., 4 flashes for 4 A).
- Set the required nominal current by repeatedly pressing the LED button. Example: Press 3 times for 3 A, this will then be shown by 3 flashes.
- Press the channel LED button for >2 seconds to save the new current value.



After 60 seconds without activity, programming mode automatically switches off.

**Note: Initial programming**

After the channel has been switched on, the channel may switch off and the LED may flash red.

- Check the currents that have been set.

### Visual signaling

Table 6-1 1- and 4-channel visual signaling

Signaling (LED)		Description
Off	LED off	Channel switched off
Green	On	Channel switched on
Yellow	On	Channel switched on, channel load >80% of the set nominal current. → Check the configuration.
	Flashing	Channel is in programming mode

Table 6-1 1- and 4-channel visual signaling

Signaling (LED)		Description
Red	On	Channel switched off, overload or short-circuit tripping, 5-second cool-down phase. → It is not possible to switch the channel on while the LED is illuminated.
	Flashing	Channel switched off, overload or short-circuit tripping. → Switch the channel back on by pressing the corresponding LED button.
Red/yellow	Flashing	Channel is in overload mode and will be switched off in approx. 5 seconds. → Check the configuration.

### 6.1.2 Programming (2-channel circuit breakers)

- Switch the channel on by pressing the corresponding LED button.
- Set the necessary nominal current via the rotary switch. The channel LED starts to flash green.
- Press the channel LED button for >2 seconds to save the new current value.



**Note: Initial programming**

After the channel has been switched on, the channel may switch off and the LED may flash red.

- Set the nominal current via the rotary switch while it is switched off. The LED now flashes red/green.
- Press the channel LED button for >2 seconds to save the new current value.

**Nominal current assistant**

- Program the channel to the highest value (e.g., 10 A).
- Start up the system so that the operating current flows.
- Turn the rotary switch down step-by-step so that it approaches the operating current that is currently flowing. This will enable you to find the appropriate setting for the channel. The channel LED flashes green in the process. If the channel LED changes and starts to flash yellow/green, the selected setting is too low for the system current that is currently flowing.
- Turn the rotary switch back up one position.
- Press the channel LED button for >2 seconds to save the new current value.

## Visual signaling

Table 6-2 2-channel visual signaling

Signaling (LED)		Description
Off	LED off	Channel switched off
Green	On	Channel switched on
	Flashing	Channel switched on, programming mode is active, and the nominal current setting differs from the saved value. → To save the set nominal current, press the channel LED button for 2 seconds or reset the rotary switch to the previous value. The previous value has been set again once the LED stops flashing.
Yellow	On	Channel switched on, channel load >80% of the set nominal current. → Check the configuration.
Red	On	Channel switched off, overload or short-circuit tripping, 5-second cool-down phase. → It is not possible to switch the channel on while the LED is illuminated.
	Flashing	Channel switched off, overload or short-circuit tripping. → Switch the channel back on by pressing the corresponding LED button.
Red/green	Flashing	Channel switched off, programming mode is active, and the nominal current was adjusted after a shut-down caused by a fault in the rotary switch. → Save the newly set nominal current by pressing the channel LED button for 2 seconds or reset the rotary switch to the previous value. The previous value has been set again once the LED only flashes red.
Yellow/red	Flashing	Channel is in overload mode and will be switched off in approx. 5 seconds. → Check the configuration.

## 6.2 Connecting loads

- Switching off the channel** Before connecting the load, make sure that the relevant channel on which the load is to be operated is switched off (colorless LED).
- Connecting the load** Connect the load via the load output of the relevant circuit breaker module as described in [Section 5, "Connecting or removing cables"](#).
- Switching on the channel** Then start the channel up again by pressing the channel LED (green LED).

## 6.3 Diagnostic and status indicators

### 6.3.1 Indicators on the power module

The power modules have a series of status LEDs to indicate the current operating state.

Table 6-3 Visual signaling of the PROFINET power module (PM PN)

LED				Description
Designation	Color	Meaning	State	
PWR	Green/yel- low/red	Voltage indicator	Green on	Operating voltage present
			Red on	Operating voltage outside the nominal voltage range
			Flashing yellow	Firmware update is in progress
			Off	Operating voltage not present
BF	Red	Bus error	On	No bus connection
			Flashing	Bus connection present, no connection to a PROFINET controller
SF	Red	System error	On	PROFINET diagnostic data available
RDY	Green	Ready	On	Device is ready for operation
			Off	Device is not ready for operation

Table 6-4 Visual signaling of the power module status-reset (PM S-R)

LED				Description
Designation	Color	Meaning	State	
PWR	Green/yel- low/red	Voltage indicator	Green on	Operating voltage present
			Red on	Operating voltage outside the nominal voltage range
			Off	Operating voltage not present

### 6.3.2 Indicators on the protective device

The protective device has one status LED per channel to indicate the current operating state of the channel.

For the signaling of the operating state and the relevant status, please refer to [Section "Programming \(1- and 4-channel circuit breakers\)" on page 31](#) and [Section "Programming \(2-channel circuit breakers\)" on page 32](#).



## 7 Process, parameter, and diagnostic data

### 7.1 Process data

The system sends and receives cyclic process data. The process data sent by the CAPAROC system to the controller is referred to as input process data below. Cyclic data sent by the controller to the CAPAROC system is referred to as output process data.

All values without "hex" are decimal values.

#### 7.1.1 Input process data slot 0/subslot 2 (global system data)

The global input process data sent from slot 0/subslot 2 is 5 bytes.

This data is structured as follows:

Table 7-1 Input process data slot 0/subslot 2

Byte offset	Data type	Bit	Description	Value range
0	Word	0 ... 7	Total current (HIGH byte)	0 ... 500 ( $\cong$ 0 ... 50.0 A)*
1		0 ... 7	Total current (LOW byte)	
2	Word	0 ... 7	Input voltage (HIGH byte)	1000 ... 3050 ( $\cong$ 10 ... 30.50 V)**
3		0 ... 7	Input voltage (LOW byte)	
4	Byte	0	Undervoltage	0 = input voltage OK 1 = input voltage <9.5 V
		1	Overvoltage	0 = input voltage OK 1 = input voltage <30 V
		2	Channel error (group message)	0 = no errors 1 = error at at least one channel
		3	I > 80% warning (group message)	0 = no I > 80% warning in the system 1 = at least 1 channel where $I \geq 80\% I_{Nom}$
		4	Total current shutdown	0 = no total current shutdown 1 = at least one module shut down due to total current overrange
		4 ... 7	Reserved	0

\* The permissible total current of the system depends on the temperature derating

\*\* The value range that can be represented does not correspond to the permissible operating voltage range

### 7.1.2 Output process data slot 0/subslot 2 (global system data)

Table 7-2 Output process data slot 0/subslot 2

Byte offset	Data type	Bit	Description	Value range
0	Byte	0	Global reset	0 = no reset command 1 = reset command for tripped channels
		1 ... 7	Reserved	0

The reset command switches all channels that were shut down by a short circuit or overload back on. The command is issued once by setting bit "0" to "1". To send another reset command, first set bit 0 to "0". Then set bit 0 to "1" again.

### 7.1.3 Input process data of CAPAROC E2 12-24DC/2-10A

A block of 3 bytes of input process data is transmitted for each channel on the device. The CAPAROC E2 12-24DC/2-10A 2-channel circuit breaker module therefore has 6 bytes of input process data.

Table 7-3 Input process data of CAPAROC E2 12-4DC/2-10A

Byte offset	Data type	Bit	Description	Value range
0	Byte	0	Switching status, channel 1	0 = channel is switched off 1 = channel is switched on
		1	Warning 80% $I_{Nom}$ , channel 1	0 = warning inactive 1 = warning active
		2	Overload, channel 1	0 = no error 1 = overload shutdown
		3	Short circuit, channel 1	0 = no error 1 = short-circuit shutdown
		4	Defect, channel 1	0 = no defect 1 = hardware is defective
		5 ... 7	Reserved	0
1	Byte	0 ... 7	Set nominal current, channel 1	{1 ... 10} A
2	Byte	0 ... 7	Flowing current, channel 1	0 ... 255 ( $\hat{=} 0 ... 25.5$ A)
3	Byte	0	Switching status, channel 2	0 = channel is switched off 1 = channel is switched on
		1	Warning 80% $I_{Nom}$ , channel 2	0 = warning inactive 1 = warning active
		2	Overload, channel 2	0 = no error 1 = overload shutdown
		3	Short circuit, channel 2	0 = no error 1 = short-circuit shutdown
		4	Defect, channel 2	0 = no defect 1 = hardware is defective
		5 ... 7	Reserved	0
4	Byte	0 ... 7	Set nominal current, channel 2	{1 ... 10} A
5	Byte	0 ... 7	Flowing current, channel 2	0 ... 255 ( $\hat{=} 0 ... 25.5$ A)

### 7.1.4 Output process data of CAPAROC E2 12-24DC/2-10A

The CAPAROC E2 12-24DC/2-10A 2-channel circuit breaker module has 2 bytes of output process data, which is defined as follows:

Table 7-4 Output process data of CAPAROC E2 12-24DC/2-10A

Byte offset	Data type	Bit	Description	Value range
0	Byte	0	Switch channel 1	0 = channel 1 off 1 = channel 1 on
		1 ... 6	Reserved	0
		7	Internal validity flag	1
1	Byte	0	Switch channel 2	0 = channel 2 on 1 = channel 2 on
		1 ... 6	Reserved	0
		7	Internal validity flag	1



The internal validity flag prevents a non-initialized process data byte from causing the unintentional shutdown of an output channel. The signal for switch-on or switch-off must be applied for at least 1500 ms. Internally, only one validity flag is available per module. The rest of the output process data for this module is also deemed valid as soon as either of the two flags is set to “1”.

## 7.2 Parameter and diagnostic data (PDI channel)

### 7.2.1 Parameters and acyclic data slot 0/subslot 2 (global system data)

The acyclic data and startup parameters can be configured as GSD parameters in the engineering tool. You can also write these parameters using the WRREC block (addressed to slot 0/subslot 2).

All values without "hex" should be interpreted as decimal values.

#### 7.2.1.1 Global nominal current programming lock (index 000B<sub>hex</sub>)

The global programming lock ensures that nominal current programming is blocked on all circuit breaker modules.

Table 7-5 Global nominal current programming lock

Byte offset	Data type	Data	Access	Default setting
0	Byte	0 = lock inactive 1 = lock active 2 = no change	r/w	0

#### 7.2.1.2 Global user interface lock (index 000C<sub>hex</sub>)

The global user interface lock ensures that operation of the circuit breaker modules via the buttons and nominal current rotary switches is blocked. Twisting the selector switch causes the channel LED to flash. When the lock is active, it is not possible to program the nominal current or to switch the channel on or off via a button.

Table 7-6 Global user interface lock

Byte offset	Data type	Data	Access	Default setting
0	Byte	0 = lock inactive 1 = lock active 2 = no change	r/w	0

#### 7.2.1.3 Global switch-on delay (index 000D<sub>hex</sub>)

The switch-on delay configures the time interval between switching on channels. The values listed below can be selected in the engineering with the GSD. The switch-on delay can also be freely programmed with the acyclic WRREC block (except for value 65535/FFFF<sub>hex</sub>).

The delay applies to all circuit breaker modules in the system.

Table 7-7 Global switch-on delay

Byte offset	Data type	Data	Access	Default setting
0	Word	Delay (HIGH byte)	r/w	50
1		Delay (LOW byte)		

Possible settings:  
 0 = minimum delay\*  
 25 = 25 milliseconds  
 50 = 50 milliseconds  
 100 = 100 milliseconds  
 150 = 150 milliseconds  
 200 = 200 milliseconds  
 500 = 500 milliseconds  
 65535 = no change

\* Depending on the system, there is always a delay of a few milliseconds

**7.2.1.4 Global operating mode (index 000E<sub>hex</sub>)**

This index configures the operating mode of the device after the voltage reset. In independent operation, the channels that were switched on prior to the voltage reset are switched on again. In the case of the “Wait for fieldbus” option, the output channels are only switched on again once the PROFINET connection has been established.

Table 7-8 Global operating mode

Byte offset	Data type	Data	Access	Default setting
0	Byte	0 = independent operation 1 = wait for fieldbus 2 = no change	r/w	0

**7.2.1.5 Resetting the application parameters to factory default settings (index 000F<sub>hex</sub>)**

This index allows the application parameters to be reset to factory default settings and is not part of the startup parameterization. For example, the WRREC block is used to write to this index. Only application parameters are reset with this index. The communication parameters, such as the station name, I&M data, and IP addresses are retained.

Table 7-9 Resetting the application parameters to factory default settings

Byte offset	Data type	Data	Access	Default setting
0	Byte	10 = reset power module 20 = reset power module and all circuit breaker modules	w	-

## 7.2.2 Parameters and acyclic data slot 1 ...16 (CAPAROC E2 12-24V/2-10A)

Read and write access for the following parameters is always 4 bytes long.

### 7.2.2.1 Nominal current setting (index 0001<sub>hex</sub>)

This index can be used to read and write the nominal current setting. The read or write command must be issued to the slot that corresponds to the module position in the system. The subplot is always "1".

Table 7-10 Nominal current setting (CAPAROC E2 12-24V/2-10A)

Byte offset	Data type	Data	Access	Default setting
0	Byte	0 = no change {1 ... 10} = nominal current channel 1*	r/w	2
1		0 = no change {1 ... 10} = nominal current channel 2*		
2		0 (reserved)		
3		0 (reserved)		

\* The nominal current is only adopted if the rotary switch is in the "RC" position (see [Section , "CAPAROC E2 ... circuit breaker"](#))

### 7.2.2.2 Local nominal current programming lock (index 0002<sub>hex</sub>)

This index can be used to read and write the local nominal current programming lock. The read or write command must be issued to the slot that corresponds to the module position in the system. The subplot is always "1".

Table 7-11 Local nominal current programming lock

Byte offset	Data type	Data	Access	Default setting
0	Byte	0 = channel 1 lock inactive 1 = channel 1 lock active 2 = no change	r/w	0
1		0 = channel 2 lock inactive 1 = channel 2 lock active 2 = no change		
2		0 (reserved)		
3		0 (reserved)		

### 7.2.2.3 Switch channels (index 0003<sub>hex</sub>)

This index can be used to switch the channels of a module on and off. The read or write command must be issued to the slot that corresponds to the module position in the system. The subplot is always "1".

Table 7-12 Switch channels

Byte offset	Data type	Data	Access	Default setting
0	Byte	0 = switch off channel 1 1 = switch on channel 1 2 = no change	r/w	0
1		0 = switch off channel 2 1 = switch on channel 2 2 = no change		
2		0 (reserved)		
3		0 (reserved)		

**7.2.2.4 Error counter (index 0004<sub>hex</sub>)**

This index can be used to read and reset the error counter for each channel. The read or write command must be issued to the slot that corresponds to the module position in the system. The subplot is always "1".

Table 7-13 Error counter

Byte offset	Data type	Data	Access	Default setting
0	Byte	0 ... 255 = error counter channel 1	r/w	0
1		0 ... 255 = error counter channel 2		
2		0 (reserved)		
3		0 (reserved)		

To reset the error counter for just one channel, the write command must be 4 bytes long. The counter to be reset must include a "0" in the byte.

**Example**

Clear error counter for channel 1 and retain error counter for channel 2:

Table 7-14 Only clear error counter for channel 1

Byte	Data
0	0
1	Any number from 1 ... 255
2	0
3	0

---

## 8 After use

### 8.1 Device replacement

In the event of a defect, replace the CAPAROC modules.

If you want to replace a CAPAROC module, proceed as follows:

- Observe the safety notes in [Section 4.1, "Safety notes for mounting and removal"](#).
- If necessary, disconnect the wiring as shown in [Section 5.3, "Removing cables"](#).
- Replace the CAPAROC module in your application with a new module. See [Section 4.5, "Replacing a module"](#).
- If necessary, connect the supply and the I/O devices. See [Section 5, "Connecting or removing cables"](#)

#### Observe the device type and version

To ensure system functionality, the new module must meet the following requirements:

- Same device type or number of channels
- Same or later version

### 8.2 Device defect and repairs

#### Do not open the housing

Repairs may only be carried out by Phoenix Contact. Do not open the housing. If the housing is opened, the function of the device can no longer be ensured.

#### Defective devices

Please contact Phoenix Contact.

### 8.3 Maintenance

CAPAROC modules are maintenance-free.

## 8.4 Decommissioning and disposal

Carry out decommissioning in accordance with the requirements of the machine or system manufacturer. When decommissioning, ensure the following for the CAPAROC modules used:

**The device will continue to be used as intended:**

- Observe the storage and transport requirements. See [Section 3, “Transport and un-packing”](#).

**The device is not used any more:**

**Device disposal**

- Do not dispose of the device with household waste; it should instead be disposed of in accordance with the currently applicable national regulations.

**Packaging disposal**

Dispose of packaging materials that are no longer needed (cardboard packaging, paper, bubble wrap sheets, tubing, etc.) with household waste in accordance with the currently applicable national regulations.

# A Appendix for document lists

## A 1 List of figures

### Section 2

Figure 2-1:	Example of a CAPAROC system .....	8
Figure 2-2:	PM PN and PM S-R power modules .....	10
Figure 2-3:	Example: 1-channel, 2-channel, and 4-channel circuit breaker modules .....	11
Figure 2-4:	Example: CR 20 and CR EXT8 Current-Rail .....	12
Figure 2-5:	Housing versions .....	13
Figure 2-6:	Design of CAPAROC PM PN .....	14
Figure 2-7:	Dimensional drawing of CAPAROC PM PN .....	14
Figure 2-8:	Design of CAPAROC PM S-R .....	15
Figure 2-9:	Design of CAPAROC E1 ... ..	16
Figure 2-10:	Dimensional drawing of CAPAROC E1 ... ..	16
Figure 2-11:	Design of CAPAROC E2 ... ..	17
Figure 2-12:	Dimensional drawing of CAPAROC E2 ... ..	17
Figure 2-13:	Design of CAPAROC E4 ... ..	18
Figure 2-14:	Dimensional drawing of CAPAROC E4 ... ..	18
Figure 2-15:	Design of CAPAROC PD 0V .....	19
Figure 2-16:	Dimensional drawing of CAPAROC PD 0V .....	19

### Section 4

Figure 4-1:	Placing and removing the module vertically .....	23
Figure 4-2:	Snapping on the modules .....	25
Figure 4-3:	Removing the Current-Rail .....	26
Figure 4-4:	Mounting distances for the CAPAROC system .....	27

### Section 5

Figure 5-1:	Connecting the CAPAROC power supply .....	30
-------------	---	----



## A 2 List of tables

### Section 1

Table 1-1:	Available documents .....	6
------------	---------------------------	---

### Section 2

Table 2-1:	Overview of power modules .....	10
Table 2-2:	Overview of adjustable circuit breaker modules.....	11
Table 2-3:	Overview of non-adjustable circuit breaker modules (fixed values) .....	11
Table 2-4:	Overview of Current-Rails.....	12
Table 2-5:	Overview of housing versions .....	13

### Section 4

Table 4-1:	Maximum number of circuit breaker modules .....	24
------------	---	----

### Section 6

Table 6-1:	1- and 4-channel visual signaling.....	31
Table 6-2:	2-channel visual signaling.....	33
Table 6-3:	Visual signaling of the PROFINET power module (PM PN) .....	34
Table 6-4:	Visual signaling of the power module status-reset (PM S-R) .....	34

### Section 7

Table 7-1:	Input process data slot 0/subslot 2 .....	37
Table 7-2:	Output process data slot 0/subslot 2.....	38
Table 7-3:	Input process data of CAPAROC E2 12-4DC/2-10A.....	39
Table 7-4:	Output process data of CAPAROC E2 12-24DC/2-10A.....	40
Table 7-5:	Global nominal current programming lock .....	41
Table 7-6:	Global user interface lock .....	41
Table 7-7:	Global switch-on delay .....	42
Table 7-8:	Global operating mode .....	42
Table 7-9:	Resetting the application parameters to factory default settings .....	42
Table 7-10:	Nominal current setting (CAPAROC E2 12-24V/2-10A).....	43
Table 7-11:	Local nominal current programming lock .....	43
Table 7-12:	Switch channels.....	44
Table 7-13:	Error counter.....	44

Table 7-14: Only clear error counter for channel 1 ..... 44

---

## Please observe the following notes

### **General Terms and Conditions of use for technical documentation**

Phoenix Contact reserves the right to alter, correct, and/or improve the technical documentation and the products described in the technical documentation at its own discretion and without giving prior notice, insofar as this is reasonable for the user. The same applies to any technical changes that serve the purpose of technical progress.

The receipt of technical documentation (in particular user documentation) does not constitute any further duty on the part of Phoenix Contact to furnish information on modifications to products and/or technical documentation. You are responsible to verify the suitability and intended use of the products in your specific application, in particular with regard to observing the applicable standards and regulations. All information made available in the technical data is supplied without any accompanying guarantee, whether expressly mentioned, implied or tacitly assumed.

In general, the provisions of the current general Terms and Conditions of Phoenix Contact apply exclusively, in particular as concerns any warranty liability.

This manual, including all illustrations contained herein, is copyright protected. Any changes to the contents or the publication of extracts of this document are prohibited.

Phoenix Contact reserves the right to register its own intellectual property rights for the product identifications of Phoenix Contact products that are used here. Registration of such intellectual property rights by third parties is prohibited.

Other product identifications may be afforded legal protection, even where they may not be indicated as such.

---

## How to contact us

### Internet

Up-to-date information on Phoenix Contact products and our Terms and Conditions can be found on the Internet at:

[phoenixcontact.com](http://phoenixcontact.com)

Make sure you always use the latest documentation.

It can be downloaded at:

[phoenixcontact.net/products](http://phoenixcontact.net/products)

### Subsidiaries

If there are any problems that cannot be solved using the documentation, please contact your Phoenix Contact subsidiary.

Subsidiary contact information is available at [phoenixcontact.com](http://phoenixcontact.com).

### Published by

PHOENIX CONTACT GmbH & Co. KG

Flachsmarktstraße 8

32825 Blomberg

GERMANY

Should you have any suggestions or recommendations for improvement of the contents and layout of our manuals, please send your comments to:

[tecdoc@phoenixcontact.com](mailto:tecdoc@phoenixcontact.com)



PHOENIX CONTACT GmbH & Co. KG  
Flachmarktstraße 8  
32825 Blomberg, Germany  
Phone: +49 5235 3-00  
Fax: +49 5235 3-41200  
E-mail: [info@phoenixcontact.com](mailto:info@phoenixcontact.com)  
**phoenixcontact.com**

© PHOENIX CONTACT 2020-11-06

109745\_en\_00  
Order No. — 00