



Lightning and surge protection basics

From the generation of surge voltages
right through to a comprehensive protection concept

In dialog with customers and partners worldwide

Phoenix Contact is a globally present, Germany-based market leader. Our group is synonym for future-oriented components, systems, and solutions in the fields of electrical engineering, electronics, and automation. A global network across more than 100 countries, and 14,500 employees ensure a close proximity to our customers, which we believe is particularly important.

The wide variety of our innovative products makes it easy for our customers to find future-oriented solutions for different applications and industries. We especially focus on the fields of energy, infrastructure, process and factory automation.

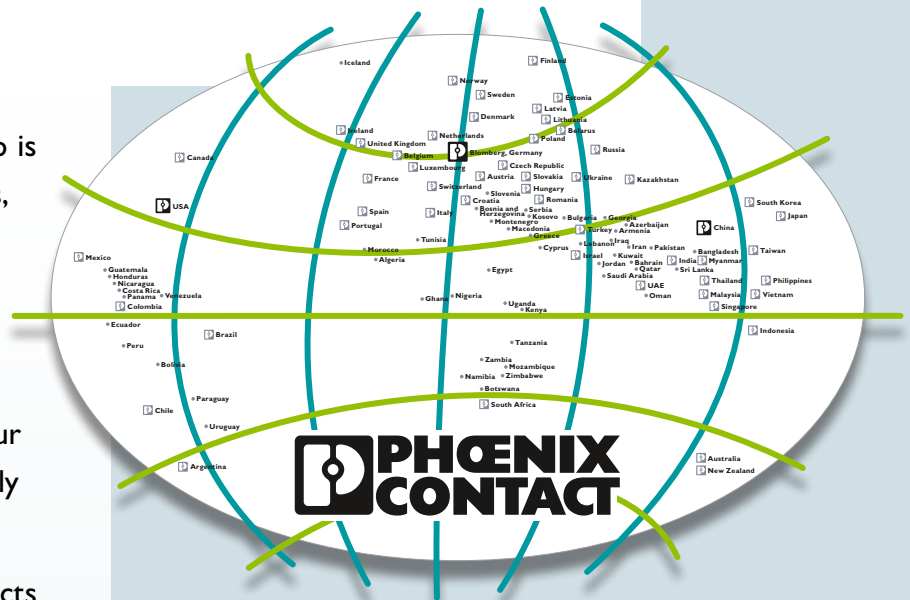



Lightning and surge protection basics

We don't just want to support you with excellent solutions, but also to be on hand with help and advice. This includes basic information about engineering and electronics topics. This brochure provides you with an overview of lightning and surge protection for electrical systems. Discover the most important facts in a nutshell. Have a look at the solutions available for the diverse challenges facing this sector. Or deepen your knowledge of the interrelationships and background; something only the specialists know.

We wish you – in the truest sense of the word – an electrifying read!

The very latest solutions

At Phoenix Contact, particular emphasis is placed on development expertise and a high degree of manufacturing capability. All key technologies, from full engineering, to tool manufacturing, metal processing, and plastic production, right through to electronics development and manufacturing are available in-house. Phoenix Contact has been developing and manufacturing surge protective devices since 1983 and is the technology leader in this area today.

The company provides many innovative solutions for every industry and application, among others, for

- Power supply
- Measurement and control technology
- Data technology and
- Transceiver systems

Phoenix Contact is distinguished by many years of experience in this area as well as by extensive expertise in both development and manufacturing. The accredited in-house lightning and high-current laboratory, the most sophisticated in the world, is just one part of this. It lays the foundation for precise, continually adjusted test procedures and basic research tailored to the application, and therefore for solutions that implement current findings from theory and practice.

In short, products with the highest levels of quality and cutting-edge technology.

Questions and answers

You probably have a great deal of questions – ranging from basic queries as to how surge voltages even occur, to technical details about grid systems or individual components of a surge protection concept, right through to the device itself. Here you can find answers to questions such as:

**What is a surge voltage?
How does it occur?**

→ Section 1, Page 6

**What damage can
surge voltages cause?**

→ Section 1.5, Page 9

How does surge protection work?

→ Section 2.1, Page 10

**What legal or standard requirements
are there for surge protection?**

→ Section 2.2, Page 11

**What makes up a consistent surge
protection concept?**

→ Section 2.3 et seqq., Page 13

**How can the quality of surge
protective devices be verified?**

→ Section 3.3, Page 18

→ Section 4, Page 22

**In which applications is surge
protection particularly important?**

→ Section 6, Page 28

Explanation of terms

→ Section 7, Page 64



Contents

1. Surge voltages	6
1.1 The phenomenon of surge voltage	6
1.2 Causes	7
1.3 Coupling types	8
1.4 Direction of action	8
1.5 Effects and damage	9

2. Surge protection: what should be considered?	10
2.1 How surge protection works	10
2.2 Lightning and surge protection standards	11
2.3 Basic protective measures and equipment	13
2.4 Lightning protection zones	14
2.5 The protective circle principle	15

3. Classification and testing of surge protective devices	16
3.1 Requirements in accordance with IEC 61643	16
3.2 Important parameters for surge protective devices	17
3.3 Maintenance and testing in accordance with IEC 62305	18
3.4 Pulse and high-current testing technology	20

4. Quality features of surge protective devices	22
4.1 CE declaration of conformity	22
4.2 Independent product certifications	23
4.3 Expertise in surge protection	24

5. Lightning monitoring system	26
5.1 Smart monitoring	26
5.2 Lightning current detection	27

6. Fields of application	28
6.1 Protection of AC systems with linear voltage sources	28
6.2 Protection of DC systems with linear voltage sources	41
6.3 Protection of DC systems in photovoltaic systems	43
6.4 Protection of signal transmission circuits in MCR technology	48
6.5 Protection of signal transmission circuits in information technology	60
6.6 Protection of signal transmission circuits in telecommunications technology	62
6.7 Protection of signal transmission circuits in transceiver systems	63

7. Glossary	64
--------------------	-----------

8. References	67
----------------------	-----------

1 Surge voltages

Various types of surge voltages can occur in electrical and electronic systems. They differ mainly with respect to their duration and amplitude. Depending on the cause, a surge voltage can last a few hundred microseconds, hours or even days. The amplitude can range from a few millivolts to some ten thousand volts. Lightning strikes are a special cause of surge voltages. Direct and indirect strikes can result not only in high surge voltage amplitudes, but also particularly high and sometimes long current flows, which then have very serious effects.

1.1 The phenomenon of surge voltage

Every electrical device has a specific dielectric strength against surge voltages. If the level of a surge voltage exceeds this strength, malfunctions or damage can occur. Surge voltages with very high amplitudes in the kilovolt range are generally transient overvoltages, which means they have a comparatively short duration, ranging from a few microseconds to several hundred microseconds. The high amplitude and

short duration, in turn, mean very abrupt voltage increases and high voltage differences, the effects of which can be protected against only with surge protection.

Although the operator of an electrical system can use corresponding insurance to fix material damage to the system, there is a separate risk for the time the system is down until it is repaired. This downtime is often not covered by

insurance and, within a short period of time, can become a heavy financial burden, especially in comparison to the cost of a lightning and surge protection concept.

1.2 Causes

The typical duration and amplitude of a surge voltage varies depending on the cause.

Lightning strikes

Lightning strikes (lightning electromagnetic pulse, LEMP) have the greatest destructive potential out of all the causes of surge voltages. They cause transient overvoltages that can extend across great distances and are often associated with high-amplitude surge currents. Even the indirect effects of a lightning strike can lead to a surge voltage of several kilovolts and result in a surge current of tens of thousands of amperes. Despite its very brief duration, from a few microseconds to several hundred microseconds, such an event can lead to total failure or even the destruction of the affected installation.

Switching operations

Switching operations generate electromagnetic pulses (switching electromagnetic pulse, SEMP), which in turn can lead to induced surge voltages that can spread to electrical cables. The current flows that are extremely high for a brief period during a short-circuit or when activating consumers with high



Fig. 1: Lightning strikes have an extremely high potential for destruction

switch-on currents can induce transient overvoltages.

Electrostatic discharges

Electrostatic discharges (ESD) occur if exposed conductive parts with different electrostatic potential approach each other, resulting in a charge exchange. This may result in electrostatic charge generation in an exposed conductive part within electrical and electronic systems. Ultimately, the electrostatic charge reaches a level high enough to spark over to an exposed conductive part of a different potential. This

sudden charge exchange leads to a brief surge voltage. This presents a hazard, especially for sensitive electronic components.



Fig. 2: High-powered electric motors induce surge voltages due to high switch-on currents

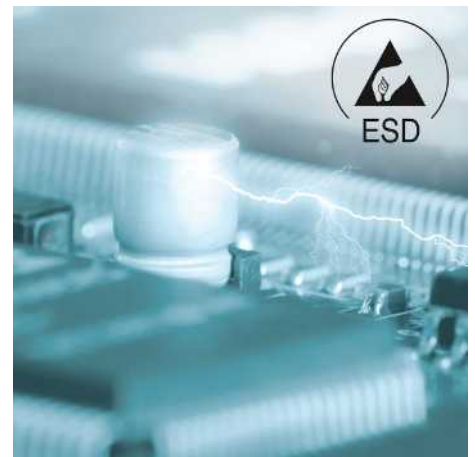

Fig. 3: Electrostatic discharges present a danger, particularly to sensitive electronics

1.3 Coupling types

Surge voltages can reach a circuit in various ways. In reality, it is usually a case of an overlap between individual coupling types.

Galvanic coupling

Two circuits that are connected to each other in an electrically conductive way can directly and mutually influence each other. A change in voltage or current in one circuit generates a corresponding reaction in another circuit.

Inductive coupling

A rapidly increasing flow of current through a conductor generates a magnetic field, with a level of strength around the conductor that quickly

changes. If another conductor is located in this magnetic field, then according to the induction principle, a voltage difference occurs here due to the change in the magnetic field strength.

Capacitive coupling

An electrical field occurs between two points with different potential. The charge carriers of exposed conductive parts within this field are arranged based on the field direction and strength according to the physical principle of influence. As such, a potential difference also occurs within the exposed conductive part, in other words, a voltage difference.

1.4 Direction of action

Normal-mode voltage (symmetrical voltage, differential mode voltage)

Symmetrical surge voltages present a hazard primarily to equipment that is located between two active potentials. They can cause damage if the electric strength of the equipment is exceeded.

Common-mode voltage (asymmetrical voltage)

Common-mode surge voltages primarily present a hazard to equipment that is located between active potentials (phase conductors and neutral conductors) and the ground potential. They can cause damage if the dielectric strength of the equipment is exceeded.

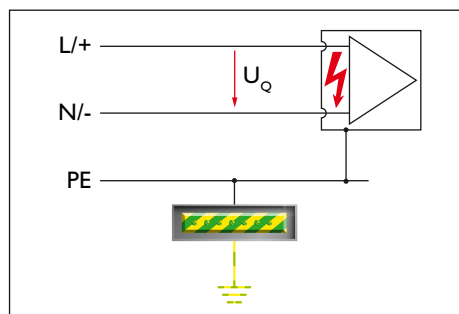

Fig. 4: Normal-mode voltage

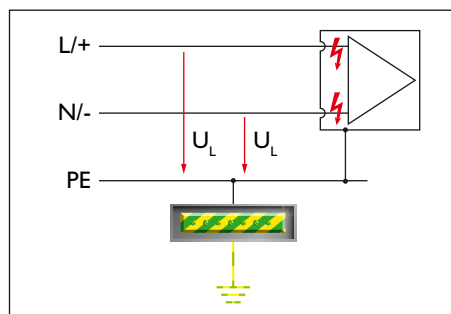

Fig. 5: Common-mode voltage

1.5 Effects and damage

The German Insurance Association (GDV) regularly publishes statistics, allowing conclusions to be drawn on the total losses resulting from various causes. According to these statistics, after fires and storms, lightning strikes and surge voltages cause the most damage. In 2012, their share of damage to all insured items totaled 18%. In other words, almost a fifth of insured damage can be traced back to a surge voltage.

Device failure or defects caused by surge voltages are more frequent than expected. According to statistics from the GDV, surge voltages are in fact the most frequent cause of this damage. These figures only apply to damage that resulted in fire.

Fig. 6 shows that the amount of damage caused by lightning and surge voltages in 2013 as reported to the GDV has dropped by about 20% in comparison to the previous year. The financial payments by insurance providers, however, fell by just 10%. If the values

from the comparable year of 2010 are taken as a basis, this amounts to a cost increase of approximately 20%. Insurers consider one of the causes to be that increasingly sensitive electronic devices are finding their way into households. On average, an individual lightning strike or damage from a surge voltage amounted to 800 euros in 2013. This is the highest amount since statistics began.

For commercial systems, however, the consequences of a failure (such as downtime or data loss) are generally much more serious. The failure of a device or a machine that is used in a professional environment often leads to costs that are many times higher than repairing the defective device.

For example, if a cell tower fails, the cost for the operator can lie in the range of several euros per second. Calculated over the course of a day, this corresponds to damages of more than 100,000 euros.

For this reason, a consistent surge protection concept is urgently required for industrial and business systems. It is not just a case of having effective protection for fire and personnel, but also about eliminating the possibility of large financial risks.

An additional factor that will underscore the need for lightning and surge protection in the future is the increase in the probability of lightning strikes, as shown by statistics. Various studies have already shown that as part of global climate change, the frequency of storms is set to increase. This development is not limited only to regions that already have a high risk of strikes, but extends to all regions on Earth.

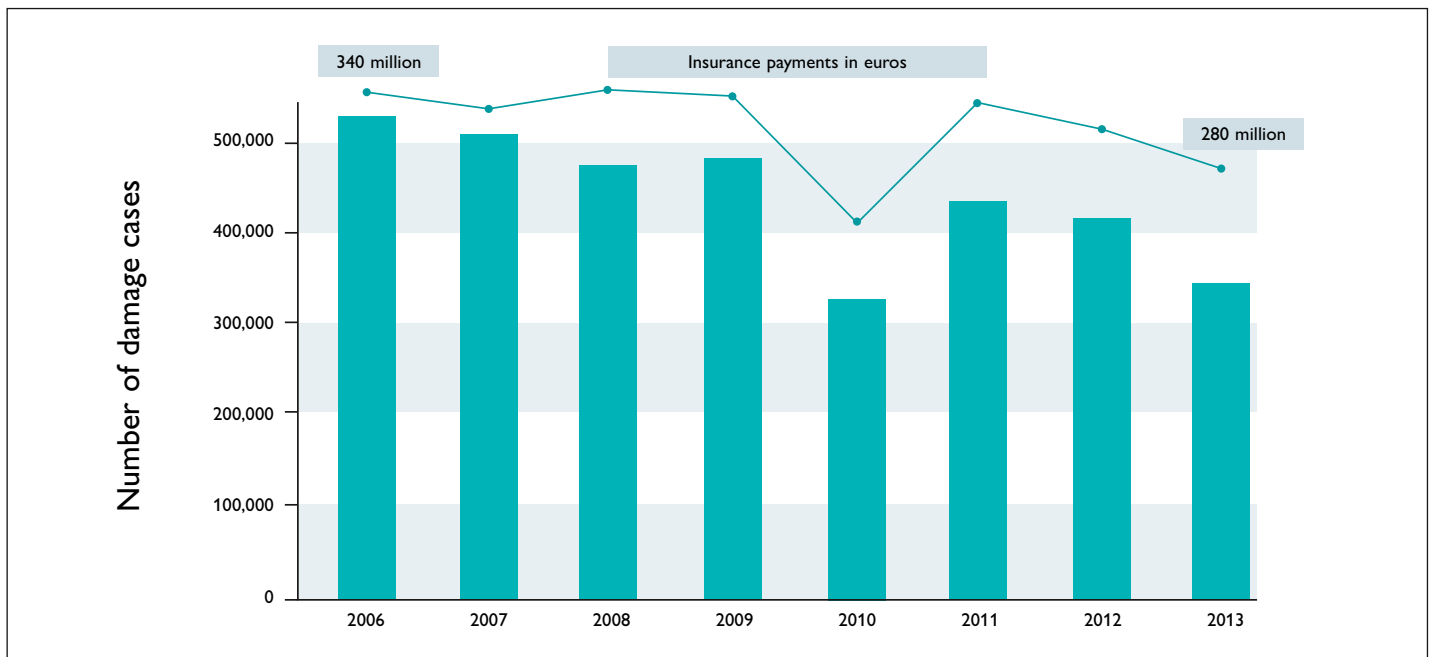

Fig. 6: Number of damage cases caused by lightning strikes and surge voltages and cost of insurance payments

2

Surge protection: what should be considered?

Effective surge protection is not just simply installed. It has to be individually coordinated based on the system that is to be protected and the ambient conditions that are prevalent on site. For this reason, the design and concept must be consistent. This means that many details must be taken into account, for everything from standards and stipulations to creating a lightning protection zone concept.

2.1 How surge protection works

Surge protection should ensure that surge voltages do not cause damage to installations, equipment or end devices.

As such, surge protective devices (SPDs) chiefly fulfill two tasks:

- Limit the surge voltage in terms of amplitude so that the dielectric strength of the devices is not exceeded.
- Discharge the surge currents associated with surge voltages to a distant ground.

The way in which the surge protection works can be easily explained by means of the equipment's power supply diagram (Fig. 7).

As described in Section 1.4, a surge voltage can arise either between the active conductors as normal-mode voltage (Fig. 8) or between active conductors and the protective conductor or ground potential as common-mode voltage (Fig. 9).

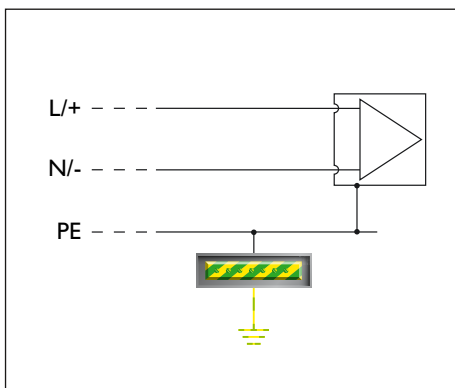

Fig. 7: Schematic power supply of a piece of equipment

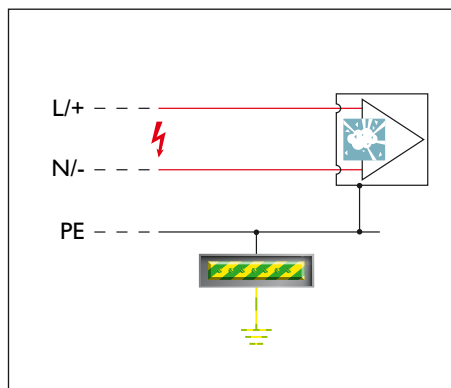

Fig. 8: Effects of a surge voltage as normal-mode voltage

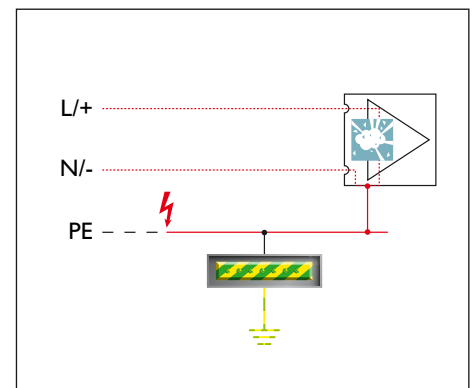

Fig. 9: Effects of a surge voltage as common-mode voltage

With this in mind, surge protective devices are installed either in parallel to the equipment, between the active conductors themselves (Fig. 10) or between the active conductors and the protective conductor (Fig. 11).

A surge protective device functions in the same way as a switch that turns off for the brief time of the surge voltage. By doing so, a sort of short circuit occurs; surge currents can flow to ground or to the supply network. This limits the difference in voltage (Fig. 12 and 13). This short circuit of sorts only lasts for the duration of the surge voltage event, typically a few microseconds. As such, the equipment to be protected is safeguarded and continues to work unaffected.

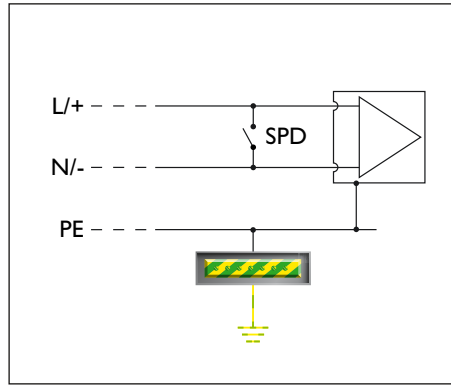

Fig. 10: SPD between the active conductors

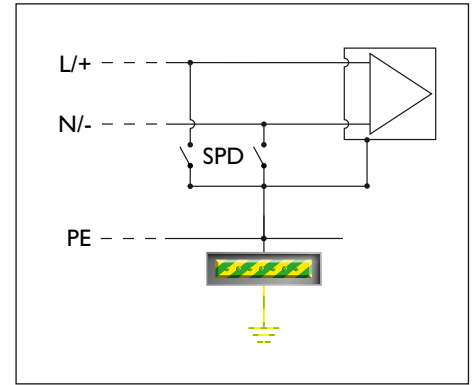

Fig. 11: SPD between active conductors and the protective conductor

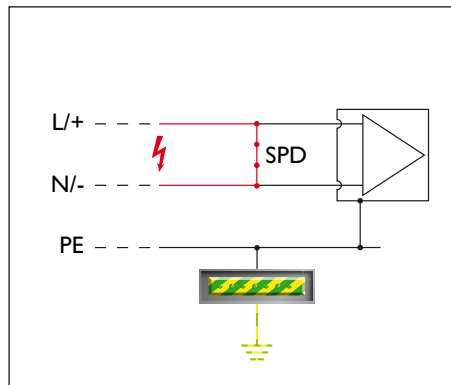

Fig. 12: SPD between the active conductors in the case of normal-mode voltage

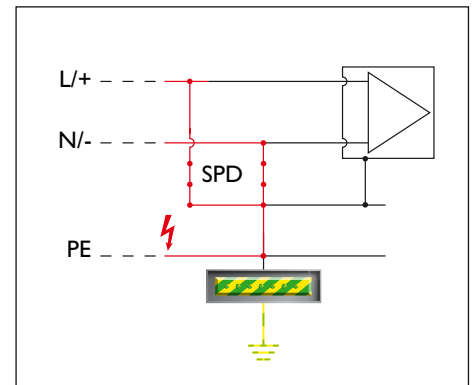

Fig. 13: SPD between active conductors and the protective conductor in the case of common-mode voltage

2.2 Lightning and surge protection standards

National and international standards provide a guide to establishing a lightning and surge protection concept as well as the design of the individual protective devices. A distinction is made between the following protective measures:

- Protective measures against lightning strike events: stipulated in lightning protection standard IEC 62305 [1] [2] [3] [4]. A key component of this is an extensive risk assessment regarding the necessity, scope, and cost-effectiveness of a protection concept.

- Protective measures against atmospheric influences or switching operations: stipulated in IEC 60364-4-44 [5]. In comparison with IEC 62305, it is based on a shortened risk analysis and uses this as the basis for deriving corresponding measures.

In addition to the standards mentioned, it may be necessary to observe other legal and country-specific stipulations, which often make the use of surge protection a compulsory requirement. The following sections do not address the individual particularities of standards

in various countries. Normative references are made, to the extent possible, based on the international IEC documents.

2.2.1 Lightning protection in accordance with IEC 62305

Part 1: Characteristics of lightning strikes

In Part 1 of this standard [1], the characteristic properties of lightning strikes, the likelihood of occurrence, and the potential for hazard are taken into account.

Part 2: Risk analysis

The risk analysis according to Part 2 of this standard [2] describes a process with which, first of all, the need for lightning protection for a physical structure is analyzed. Various sources of damage, e.g., a direct lightning strike in the building, come into focus, as do the types of damage resulting from this:

- Impact on health or loss of life
- Loss of technical services for the public
- Loss of irreplaceable objects of cultural significance
- Financial losses

The financial benefits are determined as follows: how does the total annual

cost for a lightning protection system compare to the costs of potential damage without a protection system?

The cost evaluation is based on the expenditures for the planning, assembly, and maintenance of the lightning protection system.

Parts 3 and 4: Planning aids and specifications

If the risk assessment determines that lightning protection is required and cost-effective, then the type and scope of the specific measures for protection can be planned based on Parts 3 [3] and 4 [4] of this standard. The lightning protection level determined by risk management is decisive for determining the type and scope of the measures.

For physical structures that require an extremely high level of safety, almost all strikes must be captured and conducted away safely. For systems where a higher residual risk is acceptable, strikes with lower amplitudes are not captured.

Fig. 14 shows the lowest current amplitudes of lightning strikes that can still be captured safely as well as the

highest current amplitudes of lightning strikes that can be conducted away safely depending on the lightning protection level. This is described by means of lightning protection classes I to IV.

Furthermore, these describe the probability of capturing lightning strikes relative to the overall occurrences of lightning strikes. The highest class, lightning protection class I, corresponds to a 99% probability of capturing a strike.

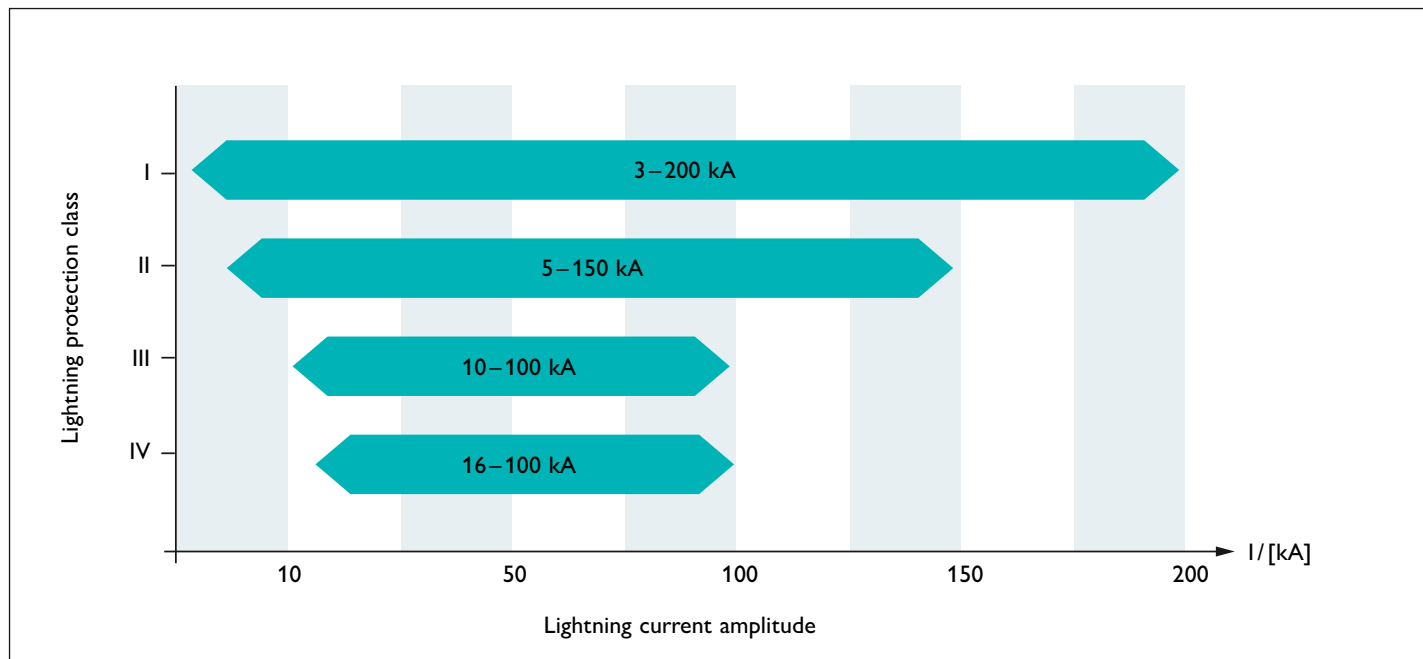

Fig. 14: Lightning protection classes in accordance with IEC 62305-1 [1] with corresponding minimum and maximum values of lightning current amplitude

2.2.2 Surge protection in accordance with IEC 60364-4-44

IEC 60364-4-44 [5] includes a description of the requirements for protecting the electrical installation against transient overvoltages caused by atmospheric influences.

The standard's area of application includes transient overvoltages that are transmitted by the power supply system. In addition to surge voltages (such as those arising from switching operations), this includes a direct lightning strike on the supply line. However, direct lightning strikes on or near a physical structure are not taken into consideration; in these cases, refer to IEC 62305 [1-4].

Likewise, the standard does not apply to installations if the consequences from surge voltages affect:

- Physical structures with a risk of explosion
- Physical structures that, if damaged, could impact the environment (such as chemical systems or nuclear power plants).

Surge protective devices must be used in accordance with IEC 60364-4-44 if transient overvoltages could have an impact on the following:

- Human life; for example, systems for safety purposes, medical areas
- Public and cultural institutions; for example, failure of public services, telecommunications centers, museums

- Industrial or trade activities; for example, hotels, banks, industrial firms, trade markets, agricultural enterprises

In all other cases, a risk assessment must be carried out in line with the international standard.

However, there are country-specific deviations in which the use of surge protection is generally obligatory, making a risk assessment unnecessary.

2.3 Basic protective measures and equipment

In order to ensure the total protection of a physical structure from the effects of lightning strikes and surge voltages, various protective measures or equipment that are tailored to one another are required. A broad classification is shown below:

- External lightning protection
- Internal lightning protection
- Grounding and equipotential bonding
- Coordinated SPD system

2.3.1 External lightning protection

External lightning protection (Fig. 15) aims to divert strikes which come near to the object to be protected and to transmit the lightning current from the point where it hits to ground. Dangerous spark formation must be prevented. Damage due to thermal, magnetic or electrical effects must be prevented as well through proper design and dimen-

sioning. External lightning protection is a system that consists of the air terminal, the arresters, and the grounding system.

Part 3 of standard IEC 62305 [3] is essential for planning and erecting external lightning protection systems. Identifying and determining the lightning protection class is the basis for this. This is derived from the risk analysis. If there are no regulations or specifications for external lightning protection, a lightning protection class of at least class III is recommended.

The location of the air terminals on the building must also be determined. There are three methods of doing so:

- Rolling sphere method
- Protective angle method
- Mesh method

To insulate the external lightning protection system, a minimum distance between electrical lines and metal installations must be kept, referred to as the separation distance.



Fig. 15 External lightning protection, here on a private residence, for example

2.3.2 Internal lightning protection

The internal lightning protection system should prevent dangerous spark formation inside the system. Sparks can be caused by lightning-induced surge voltages in the external lightning protection system or in other conductive parts of the physical structure.

The internal lightning protection system consists of the equipotential bonding system and electrical insulation due to sufficient distances or suitable materials from the external lightning protection system.

The lightning protection equipotential bonding is intended to prevent dangerous potential differences. For this purpose, the lightning protection system is primarily connected to metal installations, internal systems, as well as electrical and electronic systems within the system. This occurs by means of equipotential bonding lines, surge protective devices or isolating spark gaps.

2.3.3 Grounding and equipotential bonding

The grounding system aims to distribute and discharge the captured lightning current to ground. For this process, the geometry of the grounding system is crucial for effectively deriving lightning current (not the grounding resistance value). Effective equipotential bonding is also important. Equipotential bonding connects all electrically conductive parts with each other via cables. Active conductors are integrated into the equipotential bonding via surge protective devices.

2.3.4 Coordinated SPD system

A coordinated SPD system is understood to be a multi-level system of surge protective devices that are coordinated with each other.

The following points are recommended in order to achieve a high-performance SPD system:

- Divide the physical structure into lightning protection zones
- Incorporate all cables that cross between different zones into the local equipotential bonding using suitable SPDs
- Coordinate different types of SPDs: The devices must operate with each other in a coordinated manner to prevent individual SPDs from overloading
- Use short supply lines for connecting SPDs between active conductors and the equipotential bonding
- Lay protected and unprotected cables separately
- For surge protection of signal transmission circuits, it is recommended to ground equipment only via the respective SPD

2.4 Lightning protection zones

The installation locations of surge protective devices within a physical structure are determined using the lightning protection zone concept from part 4 of lightning protection standard IEC 62305 [4].

It divides a physical structure into lightning protection zones (LPZ), and does so from outside to inside with decreasing lightning protection levels. In external zones only resistant equipment can be used. However, in internal zones, sensitive equipment can also be used.

The individual zones are characterized and named as follows:

LPZ 0_A

Unprotected zone outside of a building where direct lightning strikes are possible. The direct coupling of lightning currents in cables and the undamped magnetic field of the lightning strike can lead to danger and damage.

LPZ 0_B

Zone outside the building that is protected from direct lightning strikes, for example, by an air terminal. The undamped magnetic field of the lightning strike and induced surge currents can cause hazards and damage.

LPZ 1

Zone inside the building where high-energy surge voltages or surge currents and strong electromagnetic fields are still to be expected.

LPZ 2

Zone inside a building where surge voltages or surge currents and electromagnetic fields that have already been significantly weakened are to be expected.

LPZ 3

Zone inside the building where surge voltages or surge currents are expected to be only extremely low or entirely absent and electromagnetic fields are expected to be only very weak or non-existent.

All cables that cross between zones must use coordinated surge protective devices (Fig. 16). Their discharge capacities are based on the lightning protection class to be achieved, which has been determined according to legal requirements and requirements from government agencies and insurance companies, or by a risk analysis. When it comes to selecting surge protective devices, use the standard as a basis, assuming that 50% of the lightning current will be discharged to ground. The other 50% of the lightning current is directed to the electrical installation via the main equipotential bonding and from there must be conducted away from the SPD system.

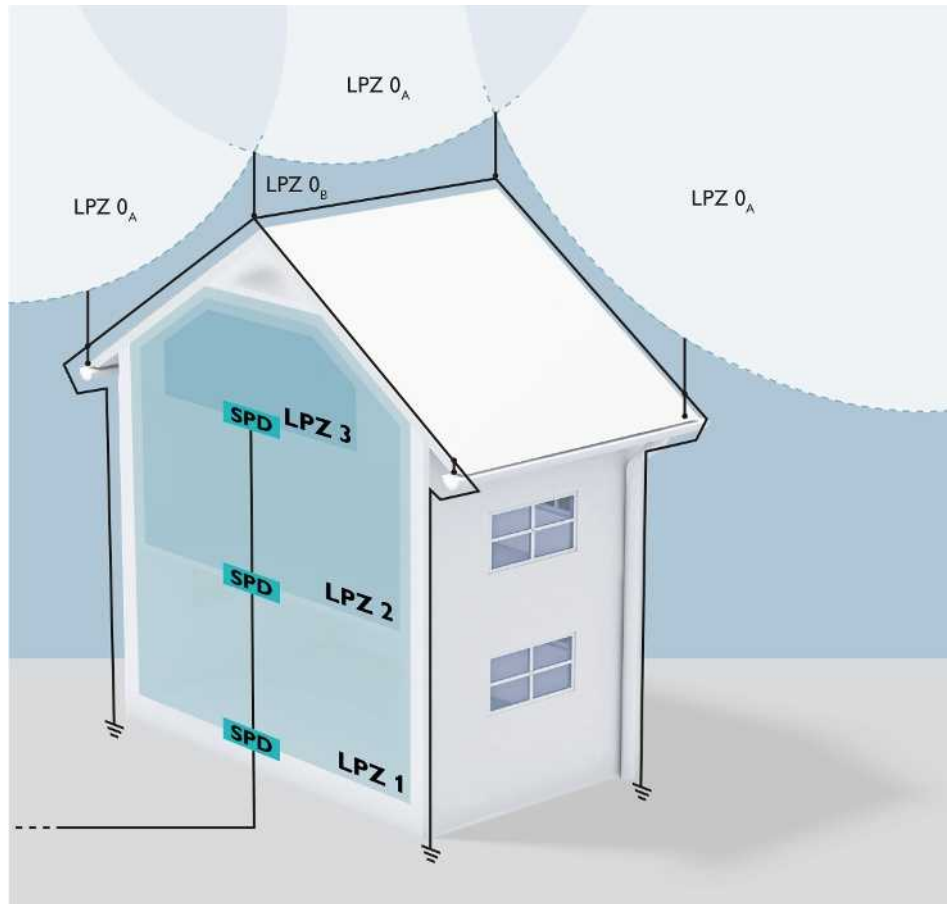

Fig. 16: Lightning protection zone concept with coordinated SPDs at the respective zone transition points

2.5 The protective circle principle

A clear depiction of the lightning protection zone concept is shown by the protective circle (Fig. 17). An imaginary circle should be drawn around the object to be protected. Surge protective devices should be installed at all points where cables intersect this circle. This secures the area inside the protective circle. Couplings of line-bound surge voltages are moderated to achieve effective protection.

The protective circle must include all electrical and electronic transmission lines in the following areas:

- Power supply
- Measurement and control technology
- Information technology
- Transceiver systems

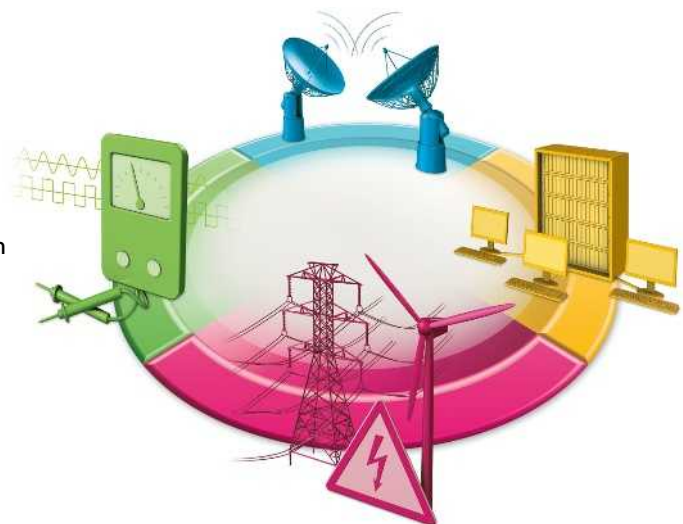

Fig. 17: Protective circle

3 Classification and testing of surge protective devices

Surge protective devices must have defined protection functions and performance parameters to make them suitable for use in corresponding protection concepts. As such, they are developed, tested, and classified according to their own international series of product standards. Yet even during use at a later stage, proper operation and therefore adherence to the protective function must be checked at regular intervals, as is also required of other safety-related components in electrical installations and electronic systems.

3.1 Requirements in accordance with IEC 61643

Surge protective devices (SPDs) are generally classified according to their performance values, depending on the protection class and location of use; this classification is found in product standard IEC 61643. It contains definitions of terms, general requirements, and testing procedures for surge protective devices. Some of the standards in the series are:

- IEC 61643-11: Surge protective devices connected to low-voltage power systems – Requirements and test methods [6]
- IEC 61643-21: Surge protective devices connected to telecommunications and signaling networks – Performance requirements and test methods [7]

- IEC 61643-31: Surge protective devices connected to low-voltage power systems – Requirements and test methods for surge protective devices to be used in photovoltaic installations [8]

In the future, the following standard will be added to this series:

- IEC 61643-41: Surge protective devices connected to low-voltage DC systems – Requirements and test methods



Fig. 18: IEC 61643 – the product standard for surge protective devices

3.2 Key characteristics for surge protective devices

Nominal voltage (U_N)

The nominal value of the voltage of the current or signal circuit based on the use envisaged for the SPDs.

The nominal voltage stated for an SPD corresponds to the system voltage of the typical SPD installation site for a standard three-phase system, e.g., 230/400 V AC. Systems with lower system voltages can also be protected by the SPD. In the event of higher system voltages, it must be decided on a case-to-case basis as to whether the SPD can be used and if there are restrictions to observe.

Nominal load current (I_L)

Maximum r.m.s. value of the nominal current, which allows a connected load to flow to one of the protected outputs of the SPD.

This maximum value is specified by the parts carrying operational current within the SPDs; these must be able to withstand the continuous thermal current load.

Short-circuit withstand capability (I_{SCCR})

Maximum prospective short-circuit current of the electrical network, for which the SPD is rated in conjunction with the upstream overcurrent protective device.

The short-circuit withstand capability indicates the maximum prospective short-circuit current at which the SPD can be used at the installation location. The corresponding tests to determine this value are carried out in connection with the maximum permissible upstream overcurrent protective device (OCPD). In the event that the special surge protective devices for photovoltaic systems correspond to the value I_{SCPV} , this is the maximum direct current short-circuit current of a system at which the SPD may be used.

Maximum continuous voltage (U_C)

Maximum r.m.s. value of the voltage that is allowed to be continuously applied to the terminals of the SPD.

The maximum continuous voltage must be at least 10% higher than the value of the nominal voltage. In systems with greater voltage deviations, SPDs with a greater difference between U_C and U_N must be used.

Voltage protection level (U_p)

Maximum voltage that can occur on the connection terminal blocks of the SPD while loaded with a pulse of specific voltage steepness and a discharge surge current of specified amplitude and wave form.

This value characterizes the surge voltage protective effect of the SPD. In the event of a surge voltage or surge current within the performance parameters of the SPD, the voltage is safely limited to a maximum of this value at the protected connections of the SPD.

Lightning surge current (I_{imp})

Peak value of the current flowing through the SPD with pulse shape (10/350 μ s).

The pulse shape (10/350 μ s) of a surge current is used for simulating the current flow of direct lightning strikes. The value of the lightning surge current is used for special testing of an SPD to demonstrate its load capacity with regard to high-energy lightning currents. Depending on the lightning protection class assigned to a lightning protection system, the SPDs must have minimum values that correspond to this peak value.

Nominal discharge current (I_n)

Peak value of the current flowing through the SPD with pulse shape (8/20 μ s).

The pulse shape (8/20 μ s) of a surge current is characteristic of the effects of an indirect lightning strike or switching operation. The value of the nominal discharge current is used for a variety of tests on an SPD, including those used to determine the voltage protection level. Depending on the lightning protection class assigned to a lightning protection system, the SPDs must have minimum values that correspond to this peak value.

Off-load voltage (U_{OC})

Off-load voltage of the hybrid generator at the terminal points of the SPD.

A hybrid generator creates a combined surge; e.g., in off-load. It supplies a voltage pulse with a defined pulse shape, generally (1.2/50 μ s), and in a short circuit, a current pulse with a defined pulse shape, generally (8/20 μ s). The combined surge is characteristic of the effects of an induced surge voltage. Depending on the protection class assigned to a lightning protection system, the SPDs must have minimum values that correspond to this value.

Normative surge current and voltage surge pulses

The voltage-limiting function of the SPDs is tested, for example, using surge currents with a pulse shape of (8/20 μ s) (Fig. 19), i.e., with a rise time of 8 μ s and a decay time to half value of 20 μ s. This pulse shape also provides information about the dynamic response behavior of the SPD. For voltage-switching SPDs, such as spark gaps or gas-filled surge protective devices, this response behavior is also tested using a very fast

voltage surge pulse with the pulse shape of (1.2/50 μ s) (Fig. 20).

SPDs that are designed to protect against direct lightning currents are additionally tested using surge currents with a pulse shape of (10/350 μ s) (Fig. 21).

The amplitude is based on the lightning surge current specified by the manufacturer for the device. This pulse shape contains several times the electrical load in comparison to the (8/20 μ s) pulse shape, at the

same amplitude. Therefore, it places a considerably higher load on the SPD in terms of energy.

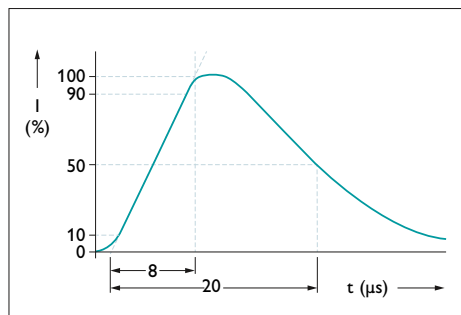

Fig. 19: Curve for a (8/20 μ s) surge current pulse

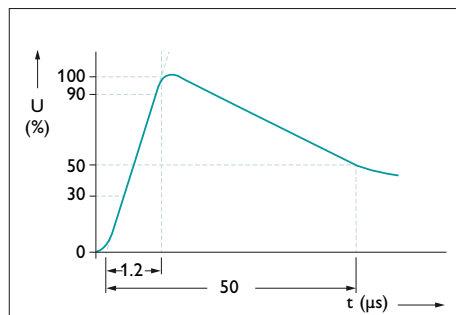

Fig. 20: Curve for a (1.2/50 μ s) voltage surge pulse

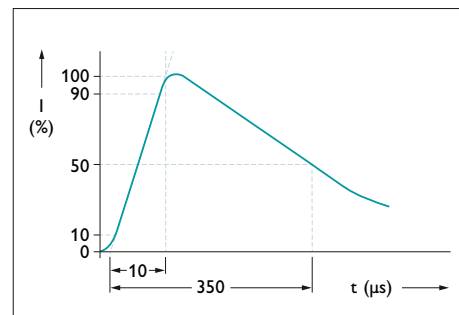

Fig. 21: Curve for a (10/350 μ s) surge current pulse

3.3 Maintenance and testing in accordance with IEC 62305

To achieve high system availability, system operators must regularly inspect and maintain their electrical system (Table 1). This is stipulated by legislators, supervisory authorities or professional associations based on the respective system type. Regular testing and maintenance of lightning protection systems (external and internal

lightning protection) is also required in Appendix E.7 of the lightning protection standard IEC 62305-3 [3]. Specialist knowledge is required in order to carry out professional testing of lightning protection systems. For this reason, this test must be carried out by a lightning protection expert. Inspecting the SPDs is also part of this. The standard also

demands that maintenance is properly documented. The three following points are particularly important to note:

Lightning protection class	Visual check (years)	Comprehensive testing (years)	Comprehensive testing in critical situations (years)
I and II	1	2	1
III and IV	2	4	1

Table 1: Testing intervals in accordance with IEC 62305-3 [3]

- "Comprehensive testing in critical situations" relates to physical structures that contain sensitive systems or systems with a large number of persons.
- Explosion-protected, physical structures should undergo a visual check every 6 months. The electrical test of the installations should be carried out once a year.
- For systems with strict requirements in terms of safety technology, for example, the legislator can prescribe a comprehensive check. This can be necessary if there has been a lightning strike within a certain radius of the respective system.

3.3.1 Electrical test

At this point the question arises as to what exactly should be covered by a comprehensive test. A visual check alone often cannot reliably provide an idea of the functional efficiency of an SPD. An electrical test, however, can clearly verify the performance capacity of the SPD.

When an electrical test is carried out on SPDs and simulates a real surge voltage, the test voltage is selected such that the SPD "works", that is, becomes conductive. The measurement results are then compared to reference values and evaluated.

3.3.2 CHECKMASTER 2 test device

The CHECKMASTER 2 (Fig. 22) is a portable, robust, and easy-to-operate high-voltage test device from Phoenix Contact for pluggable surge protective devices. It carries out an automatic, electrical test of pluggable SPDs.

Advantages

The intelligent test device with a modular design is equipped with an operating screen, a barcode scanner, and a programmable logic controller as well as a current-limiting, high-voltage power supply unit that can be controlled remotely. Thanks to the use of test adapters, the CHECKMASTER 2 can easily be adjusted to different surge protective devices. These test adapters are easy to replace without tools, and there is no need to switch off the test device.

The CHECKMASTER 2 not only detects defective surge protective devices. It is also able to detect previously damaged surge protective devices with electrical parameters that are at the limit of the defined tolerance range.

In order to also be able to check surge protective devices that will be developed in the future, software updates can be carried out via USB stick. These are available for component databases, the firmware, and operating languages.

The test record with test results, installation locations, and alphanumeric

values is stored in a failsafe manner and can be saved on a USB stick via a USB interface. It can be further processed using standard Office software (MS Word, MS Excel, etc.).

CHECKMASTER 2

The CHECKMASTER 2 enables convenient, fully-automated testing of pluggable surge protective devices. Already damaged or overloaded surge protective devices are reliably detected and can be replaced as a preventive measure. All test results are documented in line with standards.



Fig. 22: CHECKMASTER 2 high-voltage test device

3.4 Pulse and high-current testing technology

Surge protective devices are more effective the more precisely they are tailored to the requirements and special features of their area of application. Therefore, the development of surge protective devices requires laboratory simulation of the operating conditions – or more specifically, of the electrical conditions and the surge voltage events to be anticipated.

Realistic simulation of surge voltage events

For the test-based technical certification of high-performance SPDs of all types, the short-circuit behavior of high-performance, low-voltage power supply systems must be simulated. This is accomplished using an adjustable three-phase transformer with adjustable short-circuit behavior. This simulation is coupled with a surge current generator, which generates surge currents that are typically produced by transient surge voltage events. It is only with a test arrangement of this type that the performance of the protective devices can be determined, as well as their

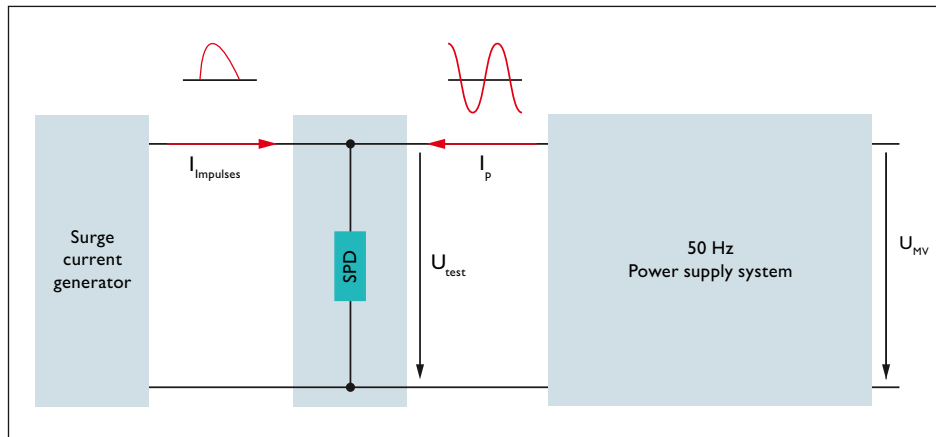

Fig. 24: 50 Hz high-current testing system for simulating different low-voltage power supply systems

interactions with different power supply systems. The IEC 61643-11 standard [6] describes a testing procedure in this context that is referred to as an operating duty test. During this test, the surge protective device is subjected to surge pulse currents while it is simultaneously connected to a specifically parameterized power supply system. The basic structure of such a testing system, which generally consists of a

surge current generator, surge protective device, and line-frequency power supply system, is depicted in Fig. 24.

Simulation of lightning surge currents

Surge current generators (Fig. 27) are key components of a high-current laboratory; they help to determine the discharge capacity, test components for external lightning protection, and



Fig. 23: Resistance and inductance on the high- and low-voltage side of the testing transformer



Fig. 25: Testing stations of the high-current testing system



Fig. 26: Fully automated testing system for determining the overload and failure behavior of surge protective devices in accordance with IEC 61643-11 [6]



Fig. 27: Lightning surge current generator

also demonstrate the function of surge voltage protection concepts. They simulate lightning surge currents with amplitudes of up to 100 kA with a pulse shape of (10/350 μ s) and surge currents, for example, consisting of switching surge voltages with amplitudes of 200 kA or higher with a pulse shape of (8/20 μ s).

Fully automated testing

The requirements for surge protective devices in accordance with IEC 61643-11 [6] call for tests (Fig. 26) that evaluate the overload and failure behavior. A key test that simulates aging of the surge protective device as a result of increasing leakage currents is the test of thermal stability. This test can take several hours. Similar time-intensive and resource-intensive testing sequences are defined in IEC 61643-21 [7] for SPDs for use in signal transmission circuits.

Accreditation in accordance with DIN EN ISO/IEC 17025

It is not only the technical equipment of the testing laboratory that counts. Just as important are the technical expertise of the employees, the effectiveness of the management system

in terms of quality assurance, as well as the independence and impartiality of the testing criteria. The essential requirements in terms of expertise for testing and calibration laboratories are described in DIN EN ISO/IEC 17025. Implementation of and adherence to this standard may, for example, be checked and confirmed by the German Accreditation Body (DAkkS).

Laboratory operation at the highest level

- Every surge voltage event can be simulated. Phoenix Contact can simulate all low-voltage power supply systems with realistic characteristics, using its in-house, three-phase 50 Hz high-current testing system. It generates maximum short-circuit currents of up to 50,000 A. Furthermore, the testing parameters can be very finely graduated and adjusted – the ideal basis for developing tailor-made surge voltage protection systems.
- Testing results that are easy to reproduce and efficient testing operation. The Phoenix Contact laboratory is automated to a high degree and is therefore suitable for ongoing quality monitoring.
- Proven to be the highest, independently verified quality. Phoenix Contact's pulse and high-current laboratory is accredited in accordance with DIN EN ISO/IEC 17025.

4 Quality features of surge protective devices

The quality and performance of surge protective devices are hard for a customer to assess. Correct functioning can only be tested in labs with appropriate equipment. Thus, aside from the external appearance and haptics, only the technical data provided by the manufacturer can provide any guidance. Even more important is a reliable statement from the manufacturer regarding the performance of the SPD and successful completion of the tests established in the respective part of the IEC 61643 standard series.

4.1 CE Declaration of Conformity

An initial statement of quality is the CE Declaration of Conformity. It certifies that the product complies with the 2014/35/EU Low-voltage Directive of the European Union. Fulfillment of the testing requirements in the EN 61643 standard series, which are based on the IEC 61643 series, serves as the primary basis for assessing surge protective devices.

Please note: The CE conformity assessment and declaration is issued by the manufacturer. It is therefore by no means a seal of approval by an independent institute or other

attestation of an examination or evaluation of the product by a third party. The CE mark only means that the manufacturer has confirmed adherence to the relevant regulations with regard to its product. If non-adherence to the relevant regulations or misuse of the CE marking is proven, legal steps can be initiated that may even result in prohibition of market launch under the European Union's supervision.



Official CE logo to mark products

4.2 Independent product certifications

A true mark of quality is a product certification from an independent testing institute. These can confirm fulfillment of the respective testing requirements specified in standards. Furthermore, they can also document additional characteristics of the products, such as resistance to the effects of shocks and vibrations or safety requirements of specific domestic markets.

The regulatory requirements placed on SPDs sometimes require highly complex tests that only a few testing laboratories in the world are fully capable of carrying out. For increasingly more manufacturers and providers of SPDs, specifically in the lower pricing segment, the specifications regarding the performance of the devices are also to be taken into account. As such, the independent certification of SPDs,

and therefore also the confirmation of performance specifications, is becoming increasingly more important.

KEMA, VDE, ÖVE, and more

These certification marks from independent testing institutes confirm, for example, that the current version of the respective testing requirements from the IEC 61643 standard series has been fulfilled.

UL, CSA, EAC, and more

These certifications are examples of requirements for certain domestic markets.

What's more, in their own standards, UL and CSA place safety requirements on the products for the North American markets or areas influenced by American markets. In contrast, EAC is primarily an

administrative approval of the products for the Eurasian Economic Area. It is the same as the CE Declaration of Conformity and can also be obtained on this basis.

GL, ATEX, IECEx, and more

These approvals certify the behavior of the products in specific ambient conditions.

GL certifies the products' resistance to external influences in the maritime environment as well as at sea, e.g., shocks, vibrations, humidity or salt concentration levels.

ATEX and IECEx, in turn, confirm the products' suitability for use in potentially explosive areas, such as those that frequently exist in the process industry.



Fig. 28: Product certifications by independent testing institutes

Independently verified quality

Phoenix Contact has a large part of its surge protection product range certified by independent testing institutes. By doing so, compliance with standards and maximum product quality are verified for the user.

4.3 Expertise in surge protection

Understanding the application

Further development of electrical systems and system technology always leads to new technologies and, as a result, to completely innovative technical solutions that place very specific requirements on surge protection. One example is the system technology for using renewable energies (photovoltaics and wind power). For this reason, it is important to fully understand the system to be protected and its environment, in order to develop tailor-made surge protective devices.

Research and development

The basis for ongoing development is intensive commitment to fundamental research and technological development. The following tasks are part of this:

- Determine the precise requirements placed on surge protective devices (protection objectives)
- Research new, appropriate materials available for applications

- Develop and master innovative basic technologies
- Structure development processes
- Develop new protection concepts as well as devices with tailor-made properties

Testing and qualification

Testing systems that simulate real conditions are essential in order to develop surge protection concepts and devices. This also applies to technical laboratory trials.

Manufacturing and quality assurance

Manufacturing surge protective devices suitable for the market with the highest quality levels demands that aspects relating to processes and procedures are taken into account during the development phase of these products. This requires early interlinking of product development activities with process and procedure development.

Measures to ensure quality are critical and should be carried out in series manufacturing as part of routine testing. For surge protective devices it can be useful, for example, to perform destructive testing that records product characteristics right up to the performance limit and beyond. In this way, any possible deviations in manufacturing processes and consequently in product quality can be detected at an early stage.



Fig. 29: Practical application

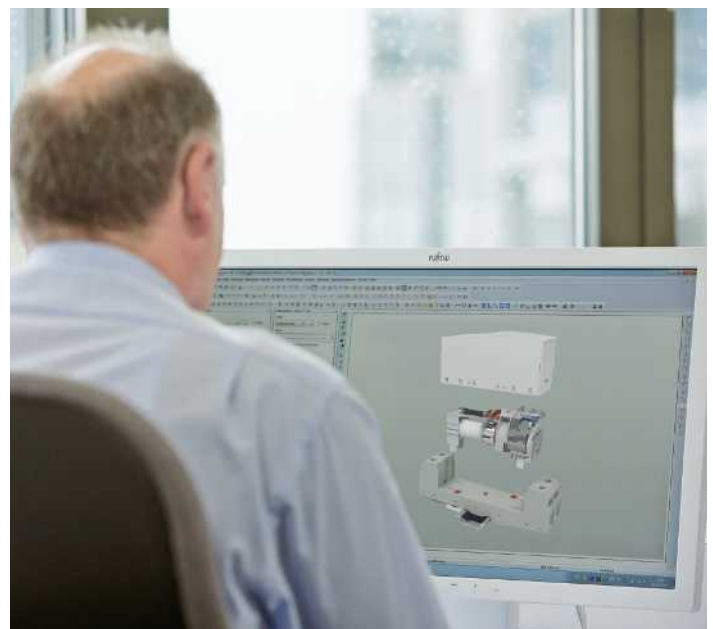

Fig. 30: Development shaped by research

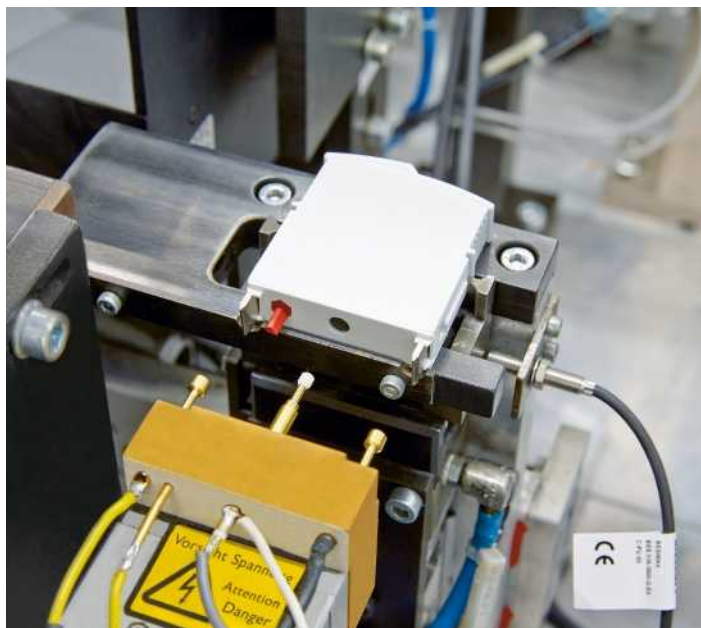

Fig. 31: Quality assurance in the production process



Fig. 32: Realistic testing conditions

A partner with experience and expertise

With Phoenix Contact as your solution provider in the field of surge protection, you benefit from many advantages:

- Basic research and technological development in-house, which open up new technologies and materials for surge protection in a targeted way and make them usable.
- Product development as part of a network, driven by collaborations with technology developers and universities as well as active involvement in relevant national and international councils and working groups.
- Operation of an in-house pulse and high-current laboratory accredited in accordance with ISO/IEC 17025, which makes it possible to fully certify surge protective devices in accordance with all current standards in the area of lightning and surge protection.
- Close interlinking of product, procedure, and process development makes it possible to implement all manufacturing aspects that are required in order to guarantee products at the highest quality level from the word go, when the product is created.
- Standardized quality tests that are carried out as automated routine testing alongside the manufacturing process as well as batch-based tests within the scope of a destructive sample test, thus ensuring products with the highest level of safety and quality.

5 Lightning monitoring system

Lightning strikes cause devastating damage to buildings and systems. They are a particular hazard for exposed structures such as offshore wind parks, radio masts, leisure facilities or high buildings. It is practically impossible for employees to continuously monitor exposed or large-scale systems, which means that damage is detected too late.

The LM-S lightning monitoring system can detect and analyze lightning strikes in real time. It provides information online about the intensity of the strike based on the influencing parameters of lightning strikes. By consolidating the system operating parameters and the measuring data, the system provides a substantiated basis for making decisions regarding control and maintenance.

5.1 Smart monitoring

Lightning strikes can cause devastating damage to buildings and systems. They can result in extensive destruction, which can also cause consequential damage.

The damage is essentially dependent on the charge of the strike. But the design of the lightning and surge protection concept also has a bearing on the extent of damage.

Systems that are particularly at risk of lightning strikes are those in exposed locations or with a large surface area, e.g., wind turbine generators, power generation systems, industrial operations covering a large area, and rail systems. In such systems, complete lightning protection is generally very difficult, or

even impossible, to implement. Damage or destruction to the system is often only monitored once consequential damage has occurred.

As a result, smart monitoring systems are used more and more. They are constantly monitoring the condition of a system. They immediately report unusual events and parameter deviations to a central evaluation unit. This helps facilitate a fast reaction to possible malfunctions or damage and, consequently, the prevention of subsequent damage and long downtimes.



Fig. 33: The lightning monitoring system

5.2 Lightning current detection

The LM-S lightning monitoring system (Fig. 33) offers the option of lightning detection: If lightning strikes a lightning rod, a magnetic field then forms around the lightning-carrying discharge. The Faraday effect dictates that such a magnetic field is able to change the polarization of light waves. The LM-S ultimately uses this effect to measure the lightning current. For this process, a light signal in front of the measuring path of the sensor is polarized. The polarization plane of the light signal is then rotated within the measuring path as it passes through the magnetic field. Using an additional polarization filter, the rotation of the light's polarization plane can be determined and subsequently the strength of the magnetic field that acted on the measuring path. In this way, the characteristics of lightning events – amplitude, lightning current slope, specific energy and charge – can

be calculated by the evaluation unit and stored along with the date and time of the lightning strike.

If lightning strikes are measured in wind turbines or buildings, conclusions can be drawn at any time from the relation between the lightning parameters and the associated harm or destruction.

Lightning information systems are used to collect information on lightning strikes for claims settlement. These systems can locate a lightning strike with a precision of up to 200 m. Whether and at what point the lightning strikes a building or system can only be determined with a lightning monitoring system such as the LM-S.

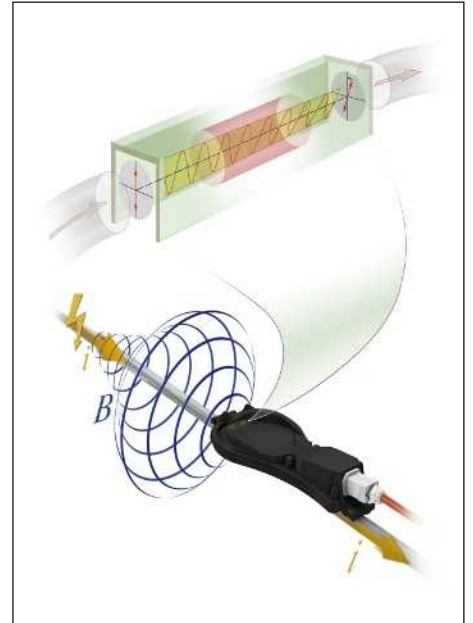

Fig. 34: Operating principle, Faraday effect



LM-S lightning monitoring system

The lightning monitoring system detects lightning strikes in the lightning protection system of a building or system. All measured data can be accessed remotely via various interfaces such as the integrated web interface or Modbus. The measured variables of the lightning strike include:

- Amplitude I_{peak}
- Gradient di/dt
- Load Q
- Specific energy W/R



Fig. 35: Burj Khalifa, LM-S application

6 Fields of application

The IEC 61643 series of standards divides the areas of application in which surge voltage protective devices are implemented into low-voltage systems, telecommunications and signal processing networks and photovoltaic installations. In general, all areas have very different individual system prerequisites. Correspondingly, the solutions or steps involved can vary greatly. It is worth examining these applications in closer detail.

6.1 Protection of AC systems

6.1.1 SPD types and technologies

The lightning protection zone concept provides coordinated surge protective devices for all cables that cross between zones. Their power values are based on the protection class to be achieved.

As such, different SPDs are required based on the zone transition points (see Table 2). The requirements for the individual SPD types are defined in the standard IEC 61643-11 [6] for surge protective devices used in low-voltage systems.

A multi-level protection concept is derived from this (Fig. 36).

Zone transition	SPD type	Designation
LPZ 0 _A → LPZ 1	Type 1	Lightn. current arrester/protective device
LPZ 0 _B → LPZ 1	Type 2	Surge protective device
LPZ 1 → LPZ 2	Type 2	Surge protective device
LPZ 2 → LPZ 3	Type 3	Device protection

Table 2: Lightning protection zone transition and corresponding SPD type

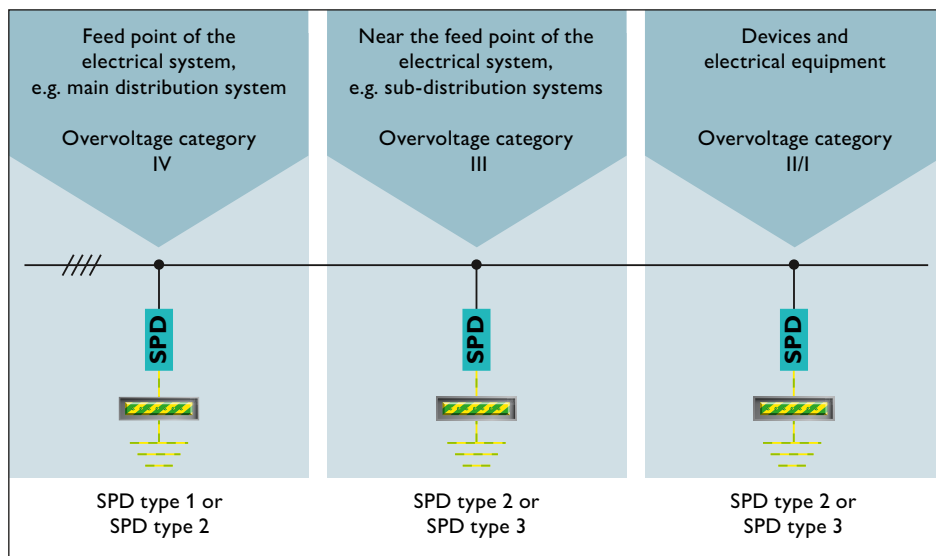

Fig. 36: Multi-level protection concept

The multi-level functionality limits the lightning protection level from zone to zone. The amplitudes and specific energy levels of the surge voltages or surge currents to be expected gradually decrease. The voltage value to which the individual SPDs must limit the surge voltages also decreases. This is achieved by correspondingly low voltage protection levels that are based on the dielectric strength of the equipment to be protected in the immediate vicinity. The dielectric strength is specified in accordance with IEC 60664-1 [9] in the overvoltage categories I to IV (Table 3).

6.1.2 Type 1: Lightning current arrester/combination protective device

Type 1 surge protective devices must fulfill the highest requirements regarding amplitude and specific energy from surge currents, as they are supposed to protect against the effects of direct lightning strikes. The demand placed on the short-circuit withstand capability is also very high in a typical main distribution installation environment. Powerful technology is needed in order to meet these requirements, such as spark gap technology.

Spark gap technology

The operating principle of a spark gap is initially very simple: Two electrodes are located at a set distance from one another. They are separated by a medium, such as air, so this arrangement initially has an isolating effect (Fig. 37). If voltage is present between the two electrodes that exceeds the electric strength of the air (approx. 3 kV/mm) in this space due to the surge voltage, an electric arc is formed. Compared with an insulating state with a resistance in the giga-ohm range, the impedance of the electric arc is extremely low and so the voltage drop across the spark gap is as well.

Nominal voltage of the power supply system		Conductor-neutral conductor voltage derived from the total nominal AC voltage or nominal DC voltage	Rated surge voltage			
Three-phase	Single-phase		Overvoltage category			
V	V	V	I	II	III	IV
		50	330	500	800	1500
		100	500	800	1500	2500
	120 – 240	150	800	1500	2500	4000
230/400		300	1500	2500	4000	6000
277/480		300	1500	2500	4000	6000
400/690		600	2500	4000	6000	8000
1000		1000	4000	6000	8000	12000

Table 3: Overvoltage categories based on the nominal voltage

This characteristic is ideal for discharging lightning currents: the lower the residual voltage of the spark gap, the lower the energy input to be managed. The non-linear characteristic regarding the abrupt change of impedance, and therefore also the voltage difference across the spark gap, is referred to as voltage switching. A significant advantage that arises from the low residual voltage is the low load on the equipment to be protected as a result of voltages above the specified nominal voltage or maximum continuous voltage. For the comparatively long duration of lightning currents, the residual voltage of a spark gap is very low, in the range of the maximum continuous voltage of the device to be protected. Type 1 SPDs with voltage-limiting components are often several hundred volts above this value – a significantly greater load for the protected equipment.

Modern spark gaps are generally encapsulated in robust steel housings, so that no ionized gases generated by the electric arc can escape into the environment during the discharge process. Furthermore, the spark gaps are triggered often. They have additional wiring to support the ignition of the

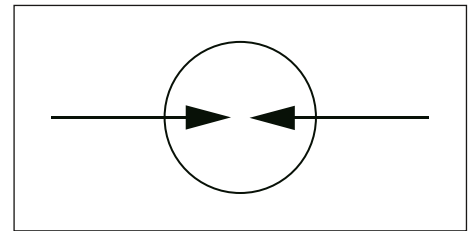

Fig. 37: Graphic symbol of an enclosed spark gap

spark gap. This limits the residual voltage to a very low level, far below the voltage that would result based on the electric strength of the air alone. Even if the installation environment of type 1 SPDs does not generally require it, the voltage protection level of modern, triggered spark gaps is often at the level of the lowest overvoltage category I (based on the nominal voltage of the system).

Follow current interrupt rating

A special characteristic for spark gaps is known as the follow current interrupt rating I_{fi} . If a spark gap is ignited by surge voltage, it forms a sort of short circuit for the connected supply network through which the current is driven.

The spark gap must therefore be in the position to suppress or interrupt the line current automatically after the discharge process, without triggering the upstream overcurrent protective device. The follow current interrupt rating indicates the maximum prospective short-circuit current at which this is guaranteed at the installation location. Modern spark gaps must therefore fulfill two functions:

- Discharging high-energy lightning currents
- Suppressing follow currents for powerful supply networks

In the case of lightning currents, the impedance of the spark gap is ideally very low, in order to keep the energy input as low as possible and minimize wear. In the case of follow currents,

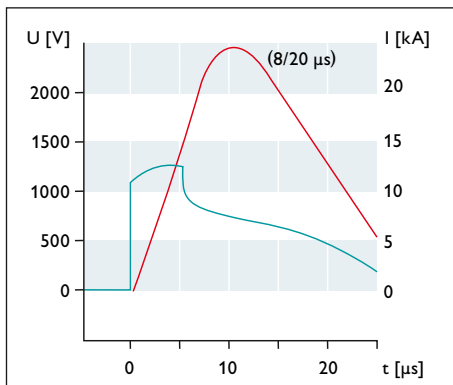

Fig. 38: Typical residual voltage curve of a triggered spark gap when loaded with a (8/20 μ s) pulse

however, the impedance must be as high as possible in order to ensure fast elimination.

In order to withstand high lightning current amplitudes of up to 50 kA on supply networks with possible short-circuit currents up to 100 kA, today's spark gaps are therefore often complex designs and consist of many individual functional parts (Fig. 39).

Spark gap technology without line follow current

For maximum system availability, limiting the line follow currents is essential:

- Upstream overcurrent protective devices are not triggered unnecessarily by line follow currents
- The installation is not loaded by additional high current flows
- Wear on the spark gap is minimized

For the first time, Phoenix Contact has been able to develop and offer a spark gap on the market that is completely free of line follow currents, featuring Safe Energy Control technology (see 6.1.10).

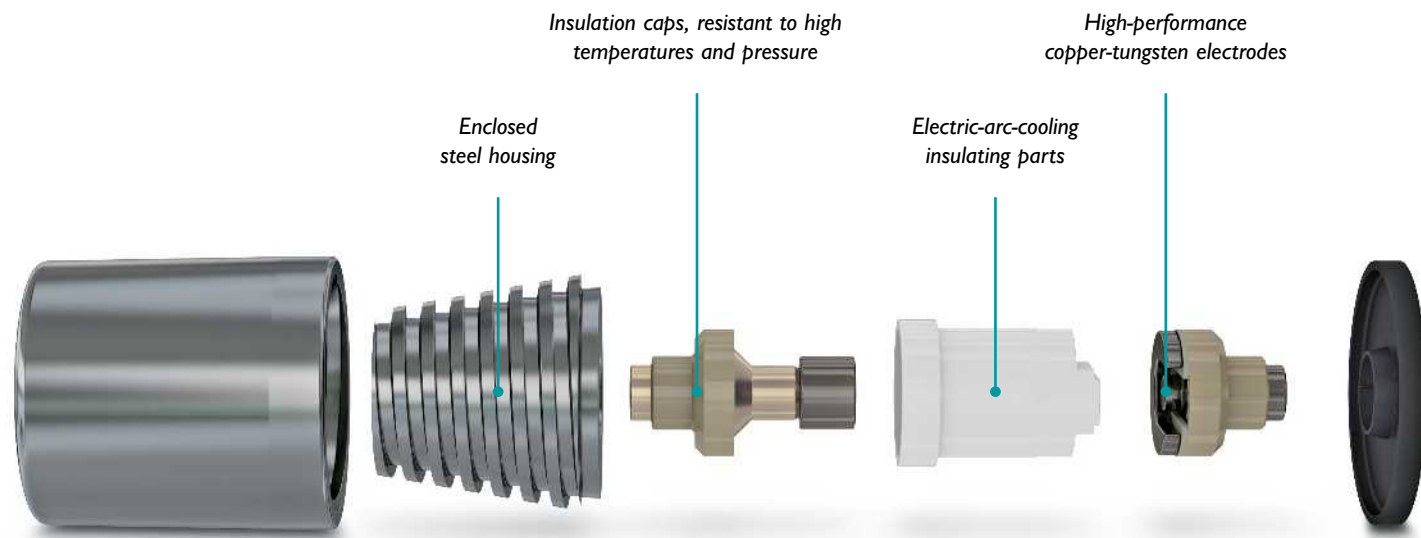

Fig. 39: Individual components of a modern, enclosed spark gap

6.1.3 Type 2: Surge protective device

Type 2 surge protective devices are generally installed in sub-distributions or machine control cabinets. These SPDs must be able to discharge induced surge voltages from indirect lightning strikes or switching operations but not handle direct lightning currents. As such, the energy input to be managed is significantly lower. In any case, induced surge voltages caused by switching operations are often very dynamic. Here, discharge technology such as varistor technology with fast response behavior stands up to the test.

have no spark gap technology often use varistors as type 1 SPDs to meet the requirements of lightning protection class I. This concept has serious defects, however. If the characteristics of the varistors connected in parallel do not match precisely, a requirement that is very hard to meet, the individual paths are placed under differing loads during the process. Correspondingly, they age very differently. The difference between loads becomes increasingly larger over time. This ultimately leads to varistor overload and consequently the failure of the entire SPD.

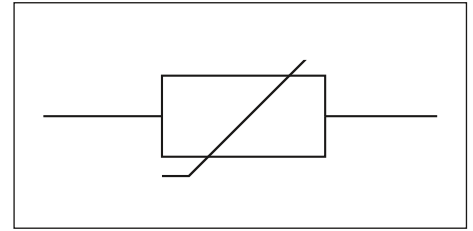

Fig. 40: Graphic symbol of a varistor

Varistor technology

Varistors (variable resistor or metal oxide varistor, MOV) (Fig. 40) are semiconductor components made from metal oxide ceramics. They exhibit a non-linear current-voltage characteristic curve (Fig. 41). In low voltage ranges, the resistance of a varistor is very high. However, in higher voltage ranges, the resistance drops away rapidly to allow very high currents to be discharged without any problems.

For this reason, the characteristics of varistors are referred to as voltage-limiting. With a typical response time in the lower nanosecond range, varistors are very well suited even to limiting particularly dynamic surge voltage phenomena.

Varistors that carry lightning current

High-performance varistor ceramics can even exhibit a pulse discharge capacity of 12.5 kA (10/350 μ s) in acceptable installation spaces. As a result, they are also suitable as type 1 SPDs for environments with low protection levels.

For a higher pulse discharge capacity of 25 kA to 50 kA (10/350 μ s), multiple varistors generally need to be used in a parallel connection. As a result, surge protection manufacturers who

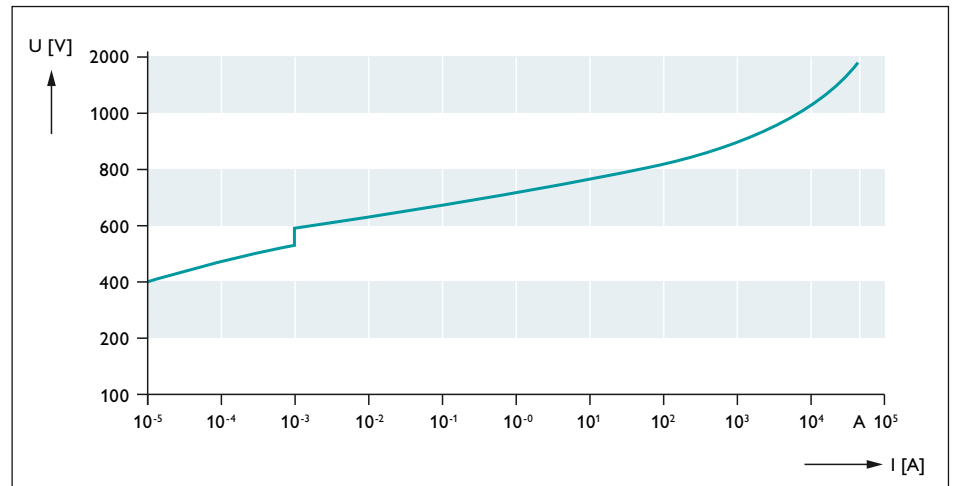

Fig. 41: Voltage-current characteristic curve of a varistor with 320 V AC rated voltage (min. and max. tolerance before and after the mA point)

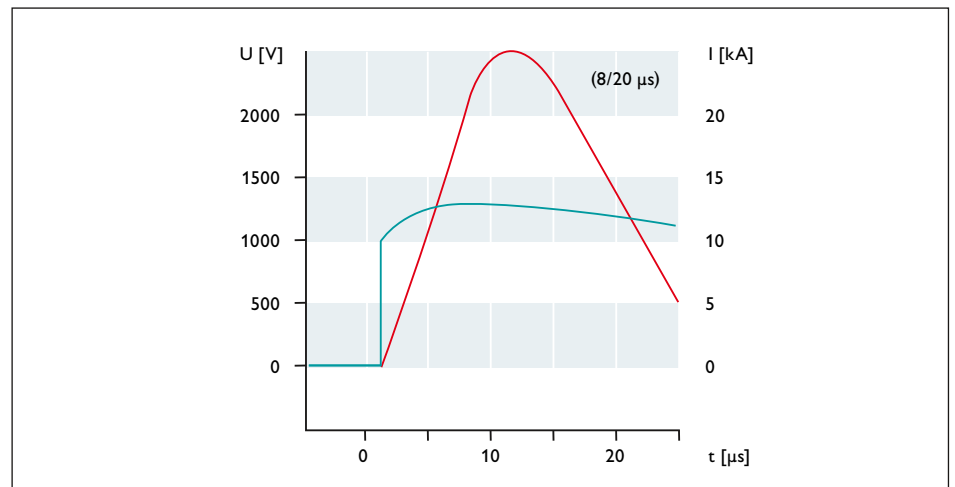

Fig. 42: Residual voltage of a varistor with 350 V AC rated voltage under a load of 25 kA (8/20 μ s)

6.1.4 Type 3: Device protection

Type 3 surge protective devices are generally installed right in front of the end devices to be protected. Due to differing installation environments, type 3 SPDs are available in a wide range of designs. In addition to standard DIN rail mounting, there are devices for installation in sockets or for direct mounting on a PCB of the end device. Technologically, type 3 SPDs are most similar to type 2, which are based on varistors, but the requirements in terms of discharge capacity in comparison to type 2 are even lower.

It is often useful to combine the protection of the power supply to the protection of other interfaces in the end device, such as data or communication lines. There are combined devices for this purpose. They take on the surge protection for all corresponding (supply) cables.

6.1.5 Coordinating different SPD types

The lightning protection zone concept provides coordinated surge protective devices for all cables that cross between zones. Their power values are based on the protection class to be achieved.

Depending on the zone transition, different types are therefore required (see Table 2). The requirements for individual SPD types are defined in the product standard for surge protective devices, IEC 61643-11 [6].

A multi-level protection concept can be derived from this (Fig. 43).

Starting from the internal protection zones, a type 3 SPD and an upstream type 2 SPD are to be coordinated. It must be ensured that type 3 SPDs do not experience energy overload. As only surge voltages of low amplitudes are to be measured in lightning protection zone 2, coordination can be accomplished using just the response behavior of the SPDs. The type 3 SPD and the components used in this device must be designed so that they only react to higher voltage values than the type 2 SPD.

In the direction of the external lightning protection zones, the coordination between type 2 SPDs and upstream type 1 SPDs must once again be ensured. As the possibility of direct lightning strikes or partial lightning strikes must be considered here that can only be borne by type 1 SPDs, it is particularly important that the SPDs are addressed selectively. Otherwise, the type 2 SPD may be overloaded.

The technologies used for type 1 SPDs are very different, so there are no generally applicable conditions for coordination. Type 1 SPDs based on spark gaps provide a clear advantage in this area. Their comparatively low residual voltage of just a few hundred volts throughout most of the duration of the lightning current ensures that almost all of the current flow is absorbed.

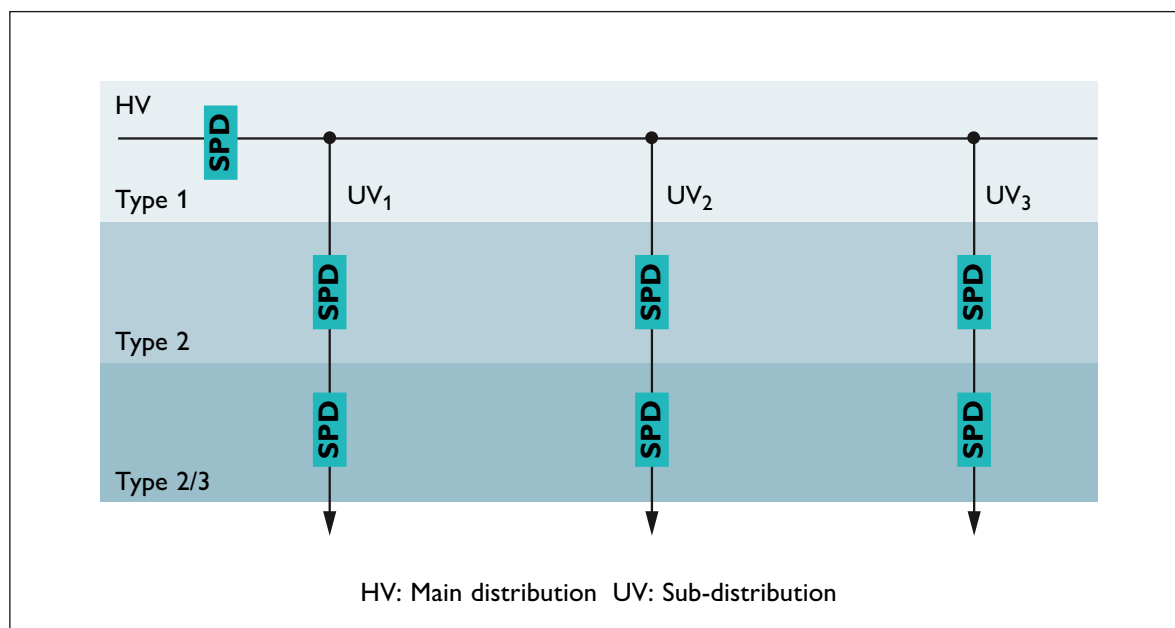

Fig. 43: Multi-level protection concept with various consecutive SPD types

6.1.6 Grid systems in accordance with IEC 60364

The design of a surge protection concept for three-phase current systems depends on the existing grid system, among other factors. These systems can vary depending on the design of the grounding of the transformer providing the supply, the consumer system, and their connection to one another.

The directive for establishing low-voltage power supply systems, IEC 60364-1 [10], lists the following system configurations:

TN-S system

In this grid system, a point of the transformer supplying the energy is grounded directly, usually the neutral point. The neutral conductor (N) and protective conductor (PE) are routed to the consumer system in separate conductors. A three-phase power supply consists of five conductors: L1, L2, L3, N, and PE (Fig. 44).

TN-C system

In this grid system, the neutral point of the transformer supplying the energy is directly grounded. The neutral conductor and protective conductor are routed to the consumer system in one conductor (PEN). A three-phase power supply consists of four conductors: L1, L2, L3, and PEN (Fig. 45).

TT system

In this grid system, the grounded point of the transformer is routed to the system solely as a neutral conductor. The parts of the electrical system are connected to a local grounding system that is separated from the grounded point of the transformer. The neutral conductor and the local protective conductor are routed to the consumer system in separate conductors. A three-phase power supply consists of five conductors: L1, L2, L3, N, and local PE (Fig. 46).

IT system

In this grid system, the neutral point of the transformer supplying the energy is not grounded, or only grounded via a high impedance. The exposed conductive parts of the electrical system are connected to a local grounding system. If a neutral conductor is also routed from the neutral point of the transformer supplying the energy, it is routed separately from the local protective conductor. A three-phase power supply consists of four or five conductors: L1, L2, L3, if appropriate, N, and local PE (Fig. 47).

One peculiarity of the IT system is that an insulation fault to ground may occur for a limited period of time. The ground fault in a phase must be simply detected by insulation monitoring and reported so that it can be promptly rectified. Only in the event of a second ground fault would this lead to a short circuit between two phases and the relevant surge protection equipment would trip. Surge protective devices for use in IT systems must therefore be able to withstand the phase-to-phase voltage of the system as well as the tolerance. This is ensured by the normative requirement that only SPDs with a maximum continuous voltage of at least the phase-to-phase voltage plus tolerance may be used between the phase and PE in IT systems.

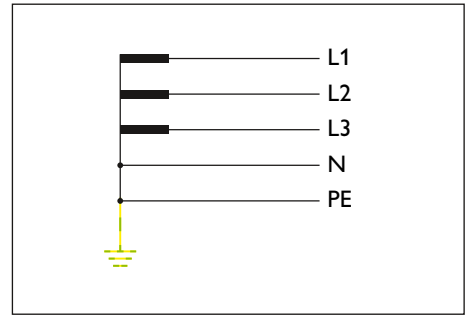

Fig. 44: TN-S system

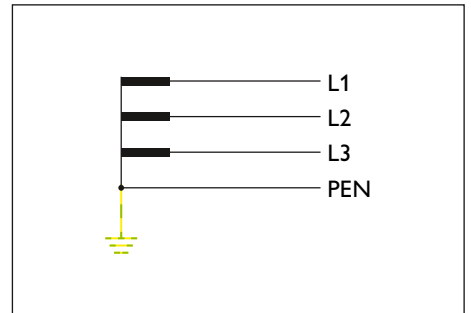

Fig. 45: TN-C system

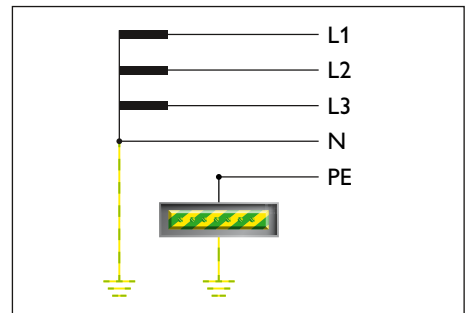

Fig. 46: TT system

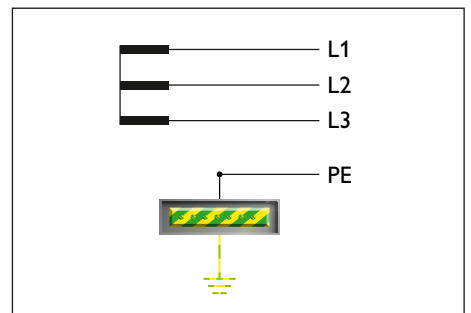

Fig. 47: IT system

6.1.7 American grid systems

Other grid systems are used, especially in the North and Central American regions. The most important are:

- Wye system
- Delta system
- Split-phase system

Wye system

These systems largely correspond to the TN systems. The neutral point of the supplying transformer is directly grounded, and from there, the protective conductor (grounding conductor, GND) is routed to the consumer system. Insulated Wye systems do exist, but there are comparatively few. Generally, a possible neutral conductor is first tapped within the consumer system. This then corresponds to a TN-C-S system. A three-phase power supply consists of four or five conductors: L1, L2, L3, if appropriate, N, and GND (Fig. 48).

Delta system

Grounding in this system either takes place via one of the phases (corner-grounded) or via a center tap between two phases (high-leg). The GND is routed from the respective grounding point to the consumer system. Insulated delta systems do exist, but there are comparatively few.

The neutral conductor is, if required, usually first tapped within the consumer system, as well. A three-phase power supply consists of four or five

conductors: L1, L2, L3, if appropriate, N, and GND (Fig. 49).

Split-phase system

This widely used two-phase system is grounded by means of a center tap on the transformer winding and a neutral conductor is routed from there. A two-phase power supply consists of four conductors: L1, L2, N, and GND (Fig. 50).

6.1.8 Connection scheme

Surge protective devices are part of the equipotential bonding of a physical structure. In the event of a surge voltage, they connect the active conductors in electrical installations with the grounding.

Depending on the grid system of the consumer system, different SPDs can be used. They are combined in various connection schemes (CT) in order to establish this connection.

In the installation directive for surge protection, IEC 60364-5-53 [11], the following types are specified:

- CT1 connection scheme: a combination of SPDs that have a mode of protection between each active conductor (outer conductor and neutral conductor, if present) and PE conductor. This connection scheme is often designated as a x+0 circuit, where x represents the number of active conductors (Fig. 51).

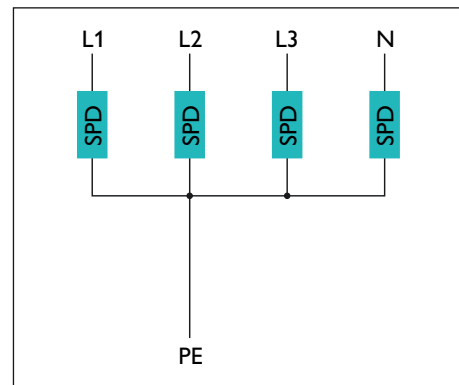

Fig. 51: CT1 connection scheme or 4+0 circuit

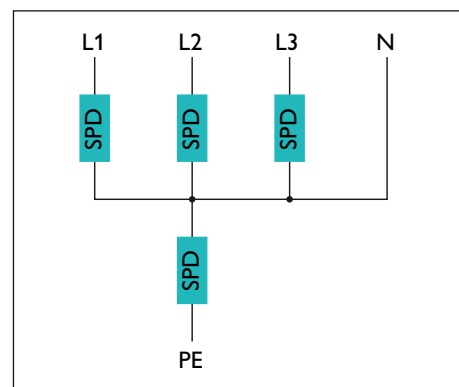

Fig. 52: CT2 connection scheme or 3+1 circuit

- CT2 connection scheme: a combination of SPDs that have a mode of protection between each outer conductor and neutral conductor and a mode of protection between the neutral conductor and the PE conductor. This connection scheme is often designated as a x+1 circuit, where x represents the number of outer conductors (Fig. 52).

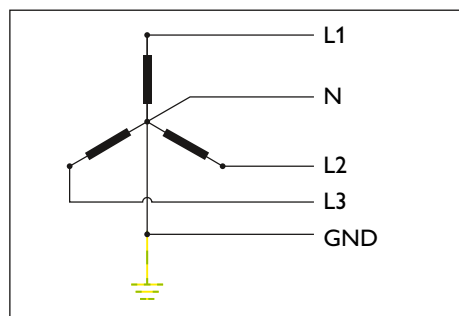

Fig. 48: Wye system

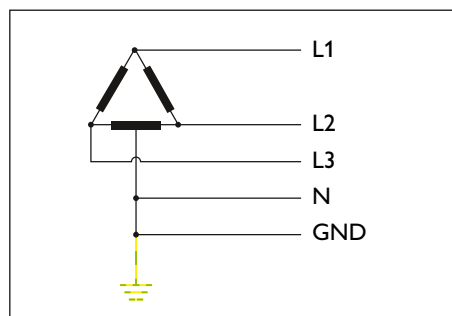

Fig. 49: Delta system (high-leg)

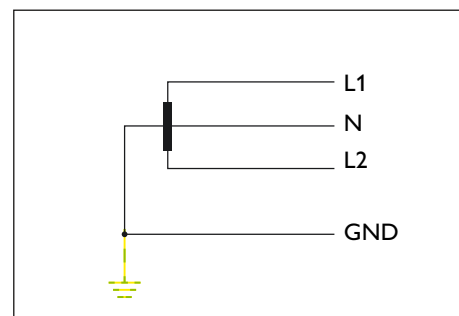

Fig. 50: Split-phase system

The possible uses of the connection schemes in the individual grid systems are listed in Table 4. When using SPDs between neutral and protective conductors in IT systems, note that the short-circuit withstand capability and, if applicable, the follow current interrupt rating of the SPD must at least match the expected short-circuit current at the installation location in the event of a two-phase ground fault.

CT2 connection scheme

For TN and TT systems, Phoenix Contact mainly provides SPDs with the CT2 connection scheme. The advantages of this connection scheme are:

- Can be used universally in all countries worldwide
- Lower voltage protection level between outer and neutral conductor
- No leakage current to the protective conductor due to the use of spark gaps between the neutral and protective conductor

6.1.9 Connection and overcurrent protection of SPDs

If transient overvoltages occur, an inductive voltage drop can result on the electrical conductors. This additional voltage drop in the connecting cables can weaken the protective effect, particularly when connecting surge protection. For this reason, the connecting cables of the SPDs are always to be routed as short as possible, avoiding small bending radii.

SPDs can essentially be connected in two different ways:

- Branch wiring (stub wiring), see Fig. 53
- V-wiring (V-shaped wiring, Kelvin connection), see Fig. 54

In both cases, the total cable lengths of a, b and c must not exceed 0.5 m whenever possible, in accordance with IEC 60364 part 5, chapter 53, section 534 [11]. This is particularly easy to ensure in the case of V-wiring, as only length c is relevant. In this way, the overall voltage protection level, consisting of the SPD voltage protection level and voltage drop along the connecting cables, can be minimized as much as possible.

In the case of branch wiring, the SPD can and must be protected, depending on the nominal value of the F1 upstream overcurrent protective device, with a second additional overcurrent protective device, F2, of a lower nominal value. This wiring enables use in systems with nominal currents of any strength, provided the prospective short-circuit current on the SPD installation location does not exceed its short-circuit withstand capability.

The V-wiring can only be used up to a nominal value of the F1 upstream overcurrent protective device or a nominal current of the system that does not exceed the continuous current capacity of the connecting cables and the SPD connection terminal blocks.

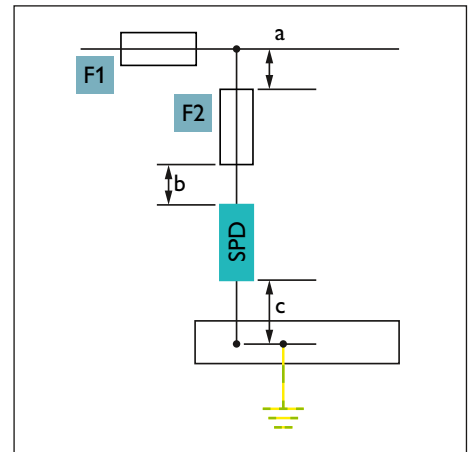

Fig. 53: Branch wiring

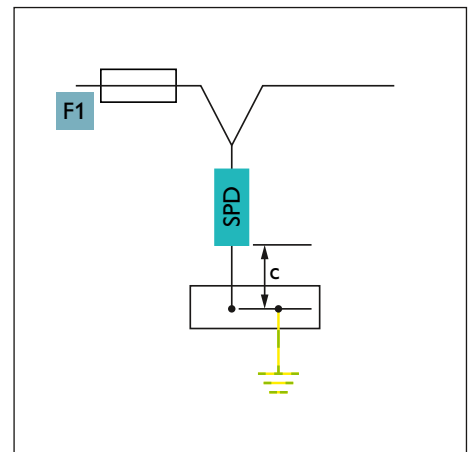

Fig. 54: V-wiring

Grid system at the SPD installation location	Connection scheme	
	CT1	CT2
TN system	✓	✓
TT system	Only downstream of a residual current operated device	✓
IT system with routed neutral conductor	✓	✓
IT system without routed neutral conductor	✓	Not applicable

Table 4: Connection schemes and grid systems

As part of the electrical installation, corresponding legal or regulatory requirements are to be fulfilled for the connection and overcurrent protection of surge protective devices. These predominantly aim to guarantee the operational reliability of the system. Furthermore, specific conditions regarding connection and fuse protection are to be taken into account for correct surge protection function.

The requirements are based on various parts of IEC 60364 for creating low-voltage systems: on the one hand, Part 5, Section 53, Main Section 534 [11], regarding the selection and setup of surge protective devices, and on the other, Part 4, Section 43 [12], regarding protective measures against overcurrent, as well as the product standard for surge protective devices, IEC 61643-11 [6].

Connection cross sections

If these requirements are combined, this results in the following conditions for dimensioning the connecting cables of SPDs (based on PVC-insulated copper cables):

- The minimum cross sections for the SPD connecting cables initially result from the requirements for installing surge protective devices, depending on the active conductor connection or the main grounding busbar/ protective conductor (PE(N)) as well as the type of the SPD:
 - Connection cross section of the active conductor for type 1 SPDs: min. 6 mm²
 - Connection cross section of the active conductor for type 2 SPDs: min. 2.5 mm²
 - Connection cross section for the main grounding busbar or the protective conductor for type 1 SPDs: min. 16 mm²
 - Connection cross section for the main grounding busbar or the protective conductor for type 2 SPDs: min. 6 mm²

- Over a specific nominal value of the upstream overcurrent protection, the minimum cross sections are determined by the connecting cables' need for short-circuit withstand capability
- If the SPD connecting cables carry operating current, then the continuous current load can be used to determine the minimum cross section as of a certain current value

Overcurrent protection

When designing the overcurrent protection of SPDs, the following elements must first be prioritized:

- Priority of the system supply: Branch wiring with separate F2 overcurrent protective device in the branch
- Priority of the system surge protection: V-wiring or branch wiring without separate F2 overcurrent protective device

In the first case, the F2 separate overcurrent protective device ensures that this is triggered in the event of an SPD failure, e.g. due to a short circuit. The F1 upstream overcurrent protective device is not triggered so that the supply of the equipment to be protected is not interrupted. In this case, however, the equipment is no longer protected from subsequent overvoltage events.

In the second case, the F1 upstream overcurrent protective device takes on the overcurrent protection in the event that the SPD fails. In this process, the failure of the supply is accepted so that no damage can arise from subsequent overvoltage events.

When dimensioning the overcurrent protection, the following points should be kept in mind:

- Selectivity of the respective overcurrent protective device to upstream overcurrent protective devices.
- The final overcurrent protective device before the SPD must not

exceed the maximum nominal value of the upstream overcurrent protective device as specified by the SPD manufacturer.

- The upstream overcurrent protective device is intended to be able to carry the amplitudes of lightning and surge current required by the lightning protection class when possible. Especially with regard to high-energy lightning currents, under-dimensioned fuses can pose a risk, as they can be destroyed in a very short time due to high-energy inputs.

Adhering to the selectivity is therefore the top priority. In the simple case that the two overcurrent protective devices to be taken into account are gG fuses, then a nominal value of 1250 A applies, which must be $F2 \times 1.6 = F1$. If one or both of the overcurrent protective devices is a circuit breaker or miniature circuit breaker, then their tripping characteristics must be compared with each other or with the fuse characteristics and, if applicable, tailored to each other. This is the case if the curves do not touch or overlap (Fig. 55 and 56). Furthermore, they must have a sufficient time interval in areas with short-circuit currents so that the respective downstream overcurrent protective device can address the other two devices and switch them off.

A similar scenario applies in the event that a miniature circuit breaker or circuit breaker is intended to provide the overcurrent protection for the SPD as F1, without a separate F2 overcurrent protective device. Then, the switching-off characteristics of the switch must be compared with the characteristics of the maximum overcurrent protection specified for the SPD by the manufacturer. This must not be exceeded in the range for short-circuit currents.

It is difficult to make general statements on this point. Statements can only be made regarding comparatively low nominal currents of switches

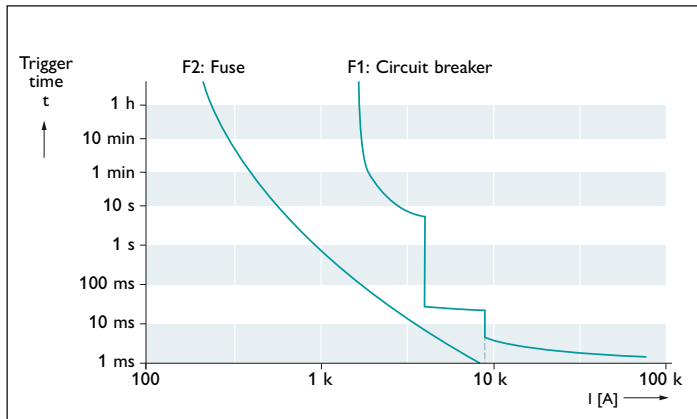

Fig. 55: Switching-off characteristics of a circuit breaker (F1) and a selective gG fuse (F2)

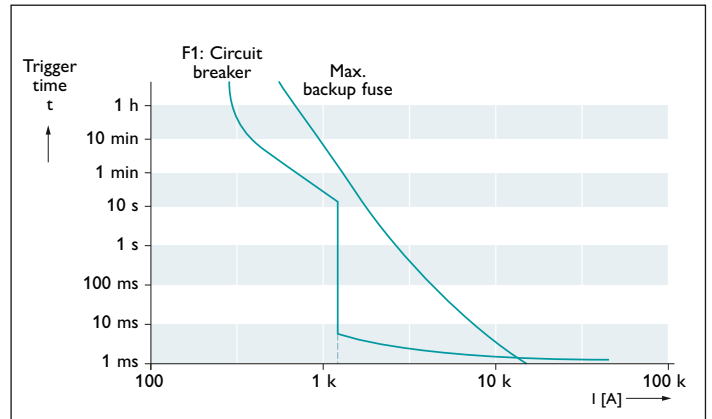

Fig. 56: Switching-off characteristics of a circuit breaker (F1) that is suited as an upstream overcurrent protective device for an SPD with maximum backup fuse of 315 A gG

compared with the nominal currents of the maximum gG backup fuses that are typical for SPDs. If, for example, a maximum backup fuse of 315 A gG is specified, then in comparison only a 125 A miniature circuit breaker of the C characteristic can generally serve as a backup fuse for the SPD. Switches with higher nominal currents or other characteristics must be considered on an individual basis and checked if necessary (Fig. 56).

SPDs with integrated overcurrent protection

A particularly simple solution for installing SPDs in view of overcurrent protection are products that already contain the corresponding fuses, such as the FLASHTRAB SEC HYBRID.



Fig. 57: FLT-SEC-H-T1-1C-264/25-FM

FLASHTRAB SEC HYBRID

Thanks to the integrated fuse, no external protection elements are required, and space and costs are significantly reduced. The protective effect is increased, as the voltage difference resulting from the fuse is already contained in the voltage protection level of the SPD. The short connecting cables required for SPDs can be easily implemented (Fig. 57).

6.1.10 Safe Energy Control technology (SEC)

Phoenix Contact provides SPDs which are perfectly matched with other items from the range and that allow multi-level protection concepts to be easily implemented. Surge protective devices with Safe Energy Control technology (SEC) combine maximum performance with a long service life, so that electrical fittings are always reliably protected and maintenance costs are reduced. Installing SPDs with SEC technology is easy, cost-effective, and space-saving. The individual SPD types can be found in the product ranges as shown in Table 5.

Impact-free and durable

A consistent surge protection concept requires a powerful type 1(2) lightning current arrester/combination protective device. Conventional type 1 spark gaps burden the installation with high line follow currents, which can also cause upstream overcurrent protection to be triggered. The SEC technology lightning current arresters/combination protective devices are the first to

SPD type	Product range
Type 1	FLASHTRAB SEC (FLT-SEC)
Type 2	VALVETRAB SEC (VAL-SEC)
Type 3	PLUGTRAB SEC (PLT-SEC)

Table 5: Product ranges with Safe Energy Control technology

feature spark gap technology with no line follow current. The prevention of line follow currents benefits the entire installation. This means that not only the protected equipment, but the entire supply, including the SPD, are placed under minimal load by the discharge process exclusively. Maximum system availability is guaranteed because the fuse protection upstream is not triggered.

Backup-fuse-free solution for every application

The powerful lightning current arresters/combination protective devices and surge protective devices with Safe Energy Control technology provide a solution for all common applications without using a separate arrester backup fuse. For applications where protecting the installation is the top priority, type 1 and type 2 SPDs can be used for main fuse ratings of 315 A gG without separate overcurrent protection. For applications beyond this scope, products are available with an integrated surge-proof fuse, such as the FLASHTRAB SEC HYBRID. The type 3 SPDs from the PLUGTRAB SEC product range can be operated in branch wiring without any kind of backup fuse, which is also thanks to the integrated surge-proof fuses.

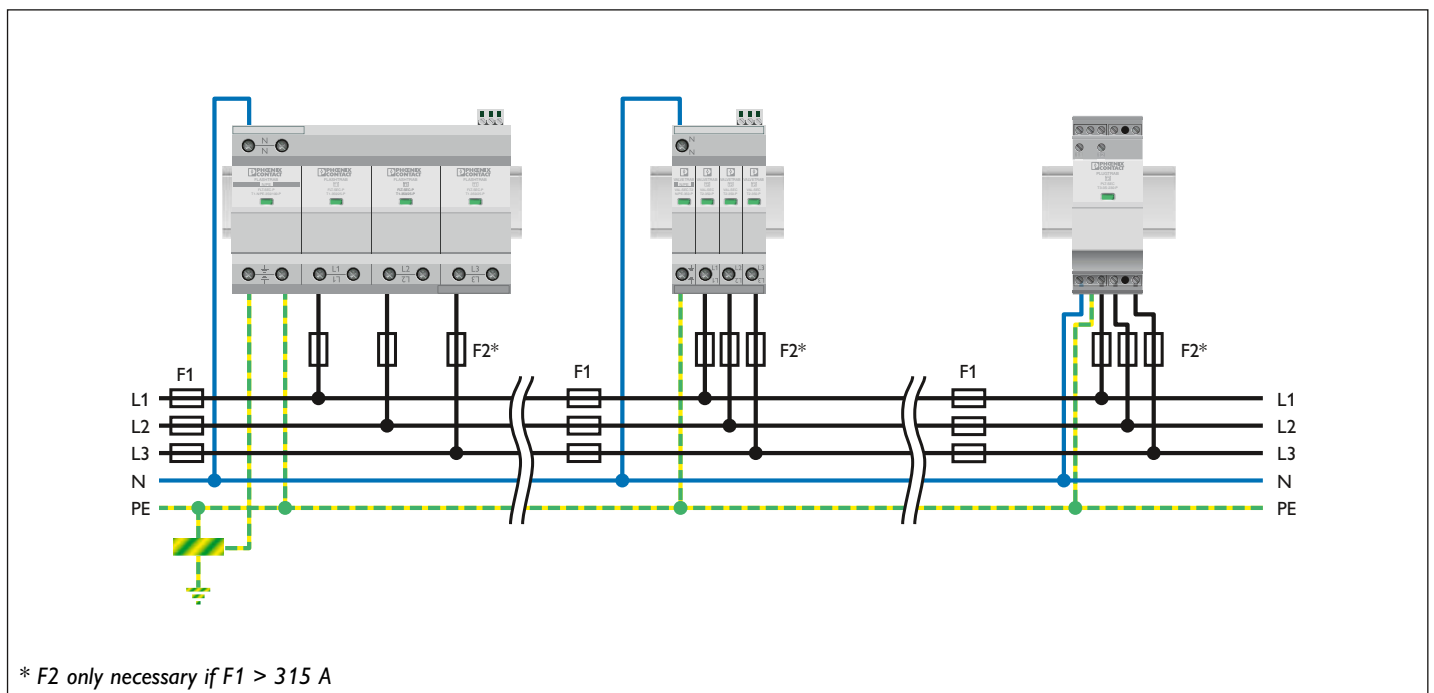

Fig. 58: Example connection of surge protective devices in a TN-S system

Compact and consistent pluggable design

The SEC range offers the most compact type 1 spark gap for this nominal voltage with the FLASHTRAB SEC PLUS 440 and the narrowest type 2 SPD with the VALVETRAB SEC. The FLASHTRAB SEC T1+T2 is the only directly coordinated combination comprised of type 1 spark gaps and type 2 varistor arrester in the smallest spaces. All products in the SEC portfolio are pluggable, making maintenance a great deal easier.

6.1.11 Multi-level protection concepts

Thanks to the SPDs from the SEC range, it is extremely easy to assemble multi-level protection concepts for standard installations. Parameters such as the maximum continuous voltage, voltage protection level and discharge capacity are ideally tailored to one another.

Industrial production system with external lightning protection system

The protective zone transition $0_A \rightarrow 1$ is provided by a type 1 SPD from the FLASHTRAB SEC product range at the point where the supply lines enter the building in the area of the low-voltage main supply. Depending on the grid system, the connection type to be selected, and the voltage level of the supply, there are various SPD types and circuit versions. If, for example, it is a three-phase 230/400 V AC TN-C system, the FLT-SEC-P-T1-3C-350/25-FM is ideal (Fig. 60).

Alternatively, the protective device combination of FLASHTRAB SEC T1+T2 (Fig. 61) can also be used here. This directly coordinated combination of a type 1 SPD on a spark-gap basis and a type 2 SPD on a varistor basis provides many advantages when used directly in the main distribution.

In further sub-distributions of the production system for machine halls and offices, the protective zone transition $1 \rightarrow 2$ is provided by type 2 SPDs from the VALVETRAB SEC product range.

A feed-in in the form of a TN-C system, as used in this example, normally becomes a TN-S system starting at the main distribution. Consequently, the rest of the installation is completed with separately laid neutral and protective conductors. The VAL-SEC-T2-3S-350-FM is offered as a type 2 SPD (Fig. 62). In machine control cabinets and in offices, the $2 \rightarrow 3$ protective zone transition is provided by means of type 3 SPDs from the PLUGTRAB SEC range, directly upstream of sensitive end devices. For an end device operated with 230 V nominal voltage, the PLT-SEC-T3-230-FM can then be used (Fig. 63).

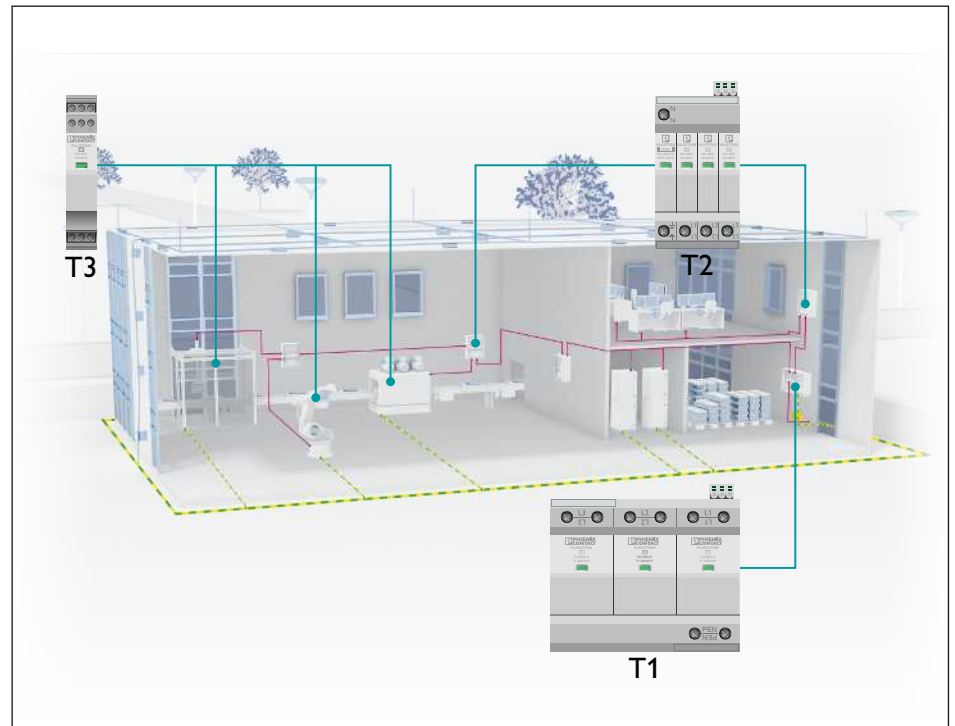

Fig. 59: Multi-level protection concept based on the example of an industrial production system

FLASHTRAB SEC

The type 1 SPDs from the FLASHTRAB SEC family all use spark gap technology that is free of line follow currents. They thereby guarantee maximum system availability, as upstream overcurrent

protection systems are not triggered as part of the discharge process, and exhibit an exceptionally long product lifetime.



Fig. 60: FLT-SEC-P-T1-3C-350/25-FM

FLASHTRAB SEC T1+T2

The unique protective device combination on the market, FLASHTRAB SEC T1+T2, optimally protects sensitive equipment by means of:

- Powerful SEC spark gap to discharge direct lightning currents

- Varistor arrester to limit dynamic surge voltages
- Ideal energy distribution between type 1 and type 2 SPDs



Fig. 61: FLT-SEC-T1+T2-3C-350/25-FM

VALVETRAB SEC

The best feature of the VALVETRAB SEC T2 is the powerful, internal thermal disconnect device, in addition to the narrow design – just 12 mm per position. The SPD can therefore be used up to 315 A gG without an additional backup fuse. It

is also possible to operate the SPD in networks that exhibit prospective short-circuit currents of up to 50 kA at the installation location.



Fig. 62: VAL-SEC-T2-3S-350-FM

PLUGTRAB SEC

The PLUGTRAB SEC T3 has integrated surge-current resistant fuses. As such, it can be used with end devices operated with both alternating current and direct current. The integrated overcurrent protection enables connection in branch wiring

without a separate backup fuse, irrespective of the nominal current and the protection of the circuit.



Fig. 63: PLT-SEC-T3-230-FM

6.2 Protection of DC systems with linear voltage sources

The operating behavior of DC systems can deviate from one another significantly due to large differences in their source characteristics. It is therefore impossible to easily select surge protective devices without precise knowledge of the properties of the respective systems. This particularly applies to systems with limited or low short-circuit currents.

Direct current power supply systems with linear source characteristics are mainly used for the following:

- Consumers with low direct current supply voltage, e.g. programmable logic controllers or telecommunication systems
- Mobile consumers, e.g. fork-lift trucks or onboard power systems
- Battery storage in UPS systems
- Computer centers
- Rail vehicles

Typical power sources of direct current power supply systems with linear source characteristics include:

- Controlled and non-controlled rectifiers with or without smoothing
- Regulated power supply units
- Charging power supply units
- Battery sets

Selecting surge protective devices

Selecting SPDs for direct current systems is generally much more complex than for alternating current power supply systems.

In the case of AC power supply systems, there is often only one, strictly defined power source; for DC systems, however, there are often multiple power sources with different operating behaviors. This particularly applies to battery-operated DC systems.

In the majority of AC systems, the minimum short-circuit current is high enough to cause upstream overcurrent protective devices to trigger in a few milliseconds. This enables easy selection of fuses that reliably protect the system in the event of failure but also are able to carry surge currents with regard to their rating. In the case of DC systems with limited or low short-circuit currents, however, it is very important that even minimal prospective short-circuit currents at the SPD installation site are detected, in order to meet basic safety requirements. Ensuring that fuses are not triggered by surge current loads is then a secondary priority.

Significant design criteria for the selection of SPDs and corresponding overcurrent protective devices in DC systems are:

- Nominal voltage of the DC power source(s)
- Number, type and operating behavior of DC power source(s)
- Maximum and minimum prospective short-circuit current at the SPD installation location



Fig. 64: VALVETRAB SEC DC

VALVETRAB SEC DC

Phoenix Contact offers type 2 SPDs for protecting DC systems with the VALVETRAB-SEC-DC product range (Fig. 64), which features an exceptionally compact design. At an overall width of just 12 mm per position, these SPDs feature an extremely powerful disconnect device capable of separating DC currents up to 200 A. This enables the use of SPDs in the application without backup fuses, among other features. Sensitive downstream components are optimally protected, thanks to the low voltage protection level.

Protective circuits for grounded and non-grounded DC systems

The preferred circuits for SPDs in DC systems conform to the CT1 connection scheme (see Fig. 51) and are designed with either one or two positions.

A 2+0 circuit is also required for grounded TN systems if the installation location of the SPDs is far away from the system's grounding point (Fig. 67).

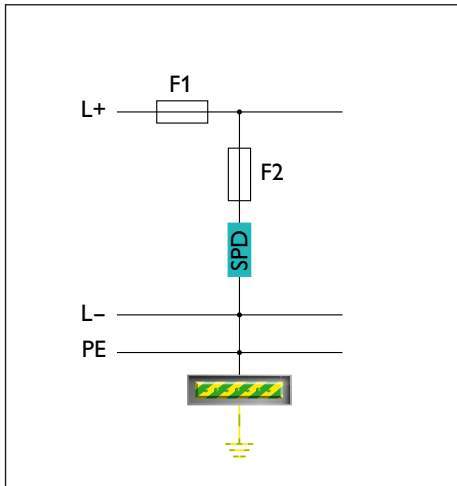

Fig. 65: 1+0 circuit for grounded TN systems at the grounding point

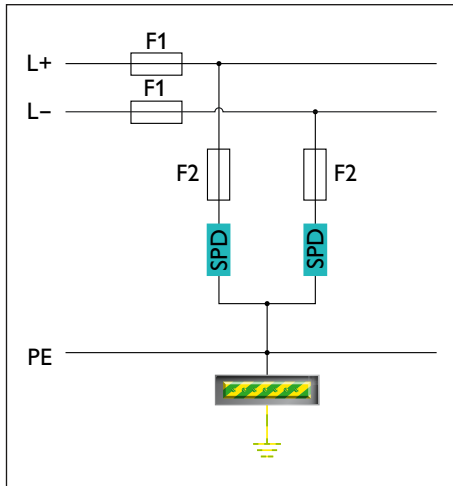

Fig. 66: 2+0 circuit for IT systems

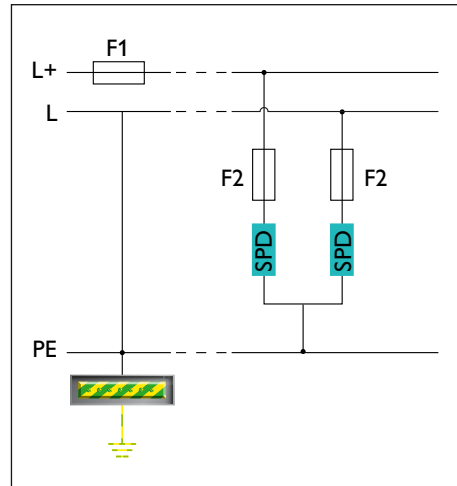

Fig. 67: 2+0 circuit for grounded TN systems that are far away from the grounding point



Fig. 68: Data center with a DC power supply system with linear source characteristics

6.3 Protection of DC systems in photovoltaic systems

The use of renewable energy sources has become increasingly important in recent years. In addition to wind turbine generators, hydroelectric plants or biomass systems, photovoltaic power generation systems (PV systems) supply a significant portion of renewable energy. PV systems are designed, for example, as rooftop systems on private homes and industrial buildings as well as free-standing systems. Due to their exposed location, these systems are susceptible to increased risk of damage by the effects of lightning. To prevent such damage and the associated loss of system availability, lightning and surge protection measures are to be considered during the design phase. Standards and directives tailored specifically to PV power supply systems make it easy to plan lightning and surge protection for these systems.

Requirements for SPDs for use in PV systems

The characteristics of PV sources impose specific requirements on SPDs for PV system protection for DC systems. Compared to conventional low-voltage power supply systems, PV systems feature the following characteristics:

- High DC system voltages up to 1500 V
- Source characteristics, which correspond to a non-linear current source
- Operating current at the optimum Maximum Power Point (MPP), which is only a few percent below the system's short-circuit current
- Dependence of the short-circuit current on ambient conditions such as irradiation and temperature

With respect to only the overload failure behavior of DC devices and components, the results have significant implications: Due to the undefined short-circuit current, it is often difficult to achieve useful coordination of overcurrent protective devices or fuses for SPDs in these systems. In addition, the non-linear source characteristics for switching operations place very high demands on the performance of switching devices, fuses and other separators.

In light of this, special requirements have been defined for using SPDs in PV systems and for testing them to verify their function. These requirements have been published for the first time in the European standard EN 50539-11. A particular focus of these standards is on the overload and failure behavior of SPDs for DC system protection. In particular, options for laboratory simulation of the source characteristics of PV systems are described in these standards. IEC 61643-31 [8] describes

this topic in terms of international standardization.

These standards form the basis for certifying SPDs for use in PV systems on the DC side with respect to their performance and especially their reliability in the event of a failure.

Selecting and installing SPDs for protection of PV systems

Effective protection against lightning currents and surge voltages is relevant for both the DC and AC parts of PV systems. Implementing this protection requires taking into account not only the general regulations for installing photovoltaic systems (IEC 60364-7-712), but also particular guidelines for selecting and installing SPDs for DC system protection. These are CLC/TS 50539-12 or subsequently CLC/TS 61643-32 as a technical specification at the European level as well as IEC 61643-32 [18] as an international counterpart.

6.3.1 PV systems on buildings

When designing and installing SPDs for protecting PV systems, it is essential to distinguish between physical structures (buildings) and free-standing systems.

In the case of physical structures, the PV system is part of a building structure and is connected to the electrical installation. The following aspects are relevant for correctly designing and installing SPDs in these systems:

- Characteristic data for supply systems, such as the network configuration, nominal voltage and short-circuit current
- Lightning protection class (LPL) to be attained
- Presence of an external lightning protection system as well as the number of protective devices that system has

- Maintaining the separation distance
- Installation location of the inverter
- Cable lengths between devices to be protected

Based on the profile of properties of the PV system to be protected, which is characterized by the above-mentioned aspects, IEC 61643-32 [18] includes recommendations for the installation locations of SPDs as well as requirements for their performance.

A distinction is made here between building installations with and without an external lightning protection system. For physical structures without an external lightning protection system, protection of the PV system is generally sufficient with one type 2 SPD with a discharge capacity of at least 5 kA (8/20 μ s) per mode of protection.

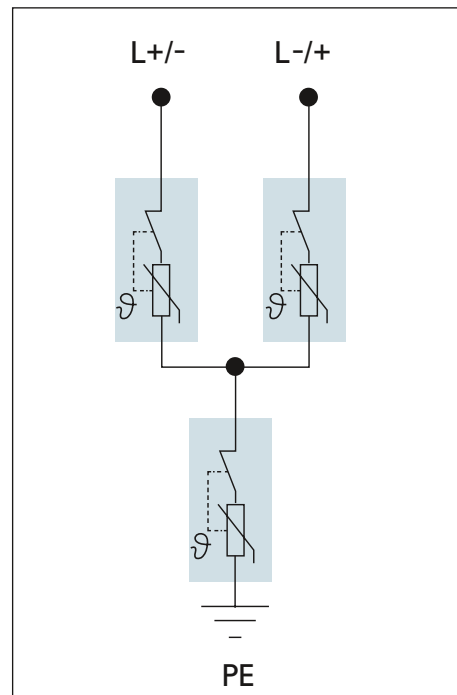

Fig. 70: Y-circuit consisting of three varistors with thermal disconnect points

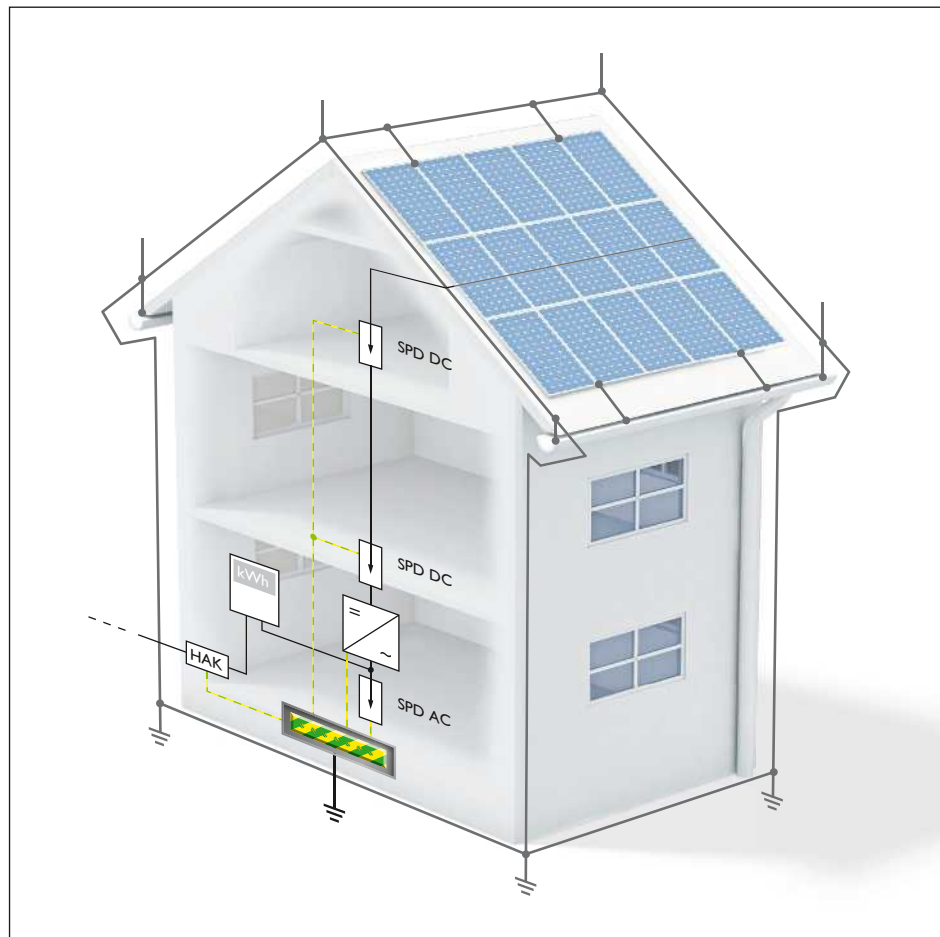

Fig. 69: Rooftop system on a private home

Advantages of the Y-circuit

All surge protective devices from Phoenix Contact for the DC-side protection of PV systems are based on the Y-circuit. This fault-resistant circuit always has two varistors with properly coordinated disconnect devices switched in series between all potentials. This ensures that even in extreme cases, when one of the varistors fails, the flow of current can reliably continue through the second without being interrupted. This ensures maximum safety.

This applies to both the DC and the AC side of the system protection, insofar as the country-specific provisions do not define any higher requirements, such as the requirement of type 1 SPDs for protecting the AC side of the system.

In the case of buildings with PV systems and an external lightning protection system for which the required separation distance between all conductive parts of the building and of the electrical installation is maintained, a type 1 SPD is required for the AC-side

system protection. Also in the case of DC-side system protection, it is sufficient to have one type 2 SPD with a discharge capacity of at least 5 kA (8/20 μ s) per mode of protection.

However, if the required separation distance is not maintained, a type 1 SPD is required for the DC-side system protection. For this purpose, IEC 61643-32 [18] defines the required discharge capacity for the SPDs to be used, depending on the lightning protection class and the SPD technology used.

The differentiation between the SPD technology used is based on the fact that the SPD itself influences the distribution of lightning current in the system and, as a result, has to discharge surge currents of different magnitudes based on the technology. IEC 61643-32 [18] makes a distinction here between voltage-limiting SPDs based on varistors and voltage-switching SPDs based on spark gaps or gas-filled surge protective devices (gas discharge tube, GDT). Combinations of these basic elements are viewed as follows: The

Voltage-limiting SPDs		 MOV MOV + GDT in series							
Lightning protection class LPL	Maximum lightning surge current (10/350 μ s)	Number of external protective devices							
		<4				≥ 4			
		Per mode of protection		I_{total}		Per mode of protection		I_{total}	
		$I_{8/20}$	$I_{10/350}$	$I_{8/20}$	$I_{10/350}$	$I_{8/20}$	$I_{10/350}$	$I_{8/20}$	$I_{10/350}$
I or unknown	200 kA	17 kA	10 kA	34 kA	20 kA	10 kA	5 kA	20 kA	10 kA
II	150 kA	12.5 kA	7.5 kA	25 kA	15 kA	7.5 kA	3.75 kA	15 kA	7.5 kA
III or IV	100 kA	8.5 kA	5 kA	17 kA	10 kA	5 kA	2,5 kA	10 kA	5 kA

Table 6: Values for voltage-limiting SPDs in the PV application on a building where the separation distance is not maintained

Voltage-switching SPDs		 GDT MOV + GDT parallel							
Lightning protection class LPL	Maximum lightning surge current (10/350 μ s)	Number of external protective devices							
		<4				≥ 4			
		Per mode of protection		I_{total}		Per mode of protection		I_{total}	
		$I_{10/350}$		I_{total}		$I_{10/350}$		I_{total}	
I or unknown	200 kA	25 kA		50 kA		12.5 kA		25 kA	
II	150 kA	18.5 kA		37.5 kA		9 kA		18 kA	
III or IV	100 kA	12.5 kA		25 kA		6.25 kA		12.5 kA	

Table 7: Values for voltage-switching SPDs in the PV application on a building where the separation distance is not maintained

series connection consisting of varistor and GDT is also viewed as voltage-limiting, while the parallel connection is viewed as voltage-switching. For effective system protection, IEC 61643-32 [18] also provides instructions on the number of SPDs to be installed and the optimum installation location. To protect the inverter, follow the recommendation to install the SPDs as close to it as possible.

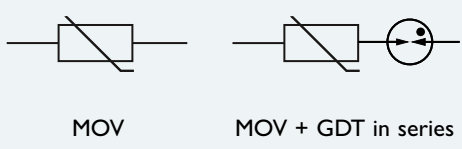
If the cable length between PV panels and inverters exceeds 10 m, install an additional protective device at the other end of the cable in the area of the PV panels to protect these effectively, too.

In systems with an external lightning protection system where the separation distance is not maintained, it is also necessary for the metal frames and carrier systems of the PV panels to be connected to the lightning protection system with connectors that are able to carry lightning current. In this case, regardless of the respective cable length, a type 1 SPD has to be installed at each installation site. The reason for this is that all cables of the PV system are considered parallel paths to the equipotential bonding lines and the building's protective devices and, connected via the SPDs, must carry partial lightning currents.

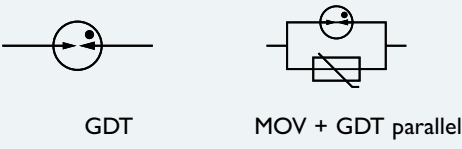
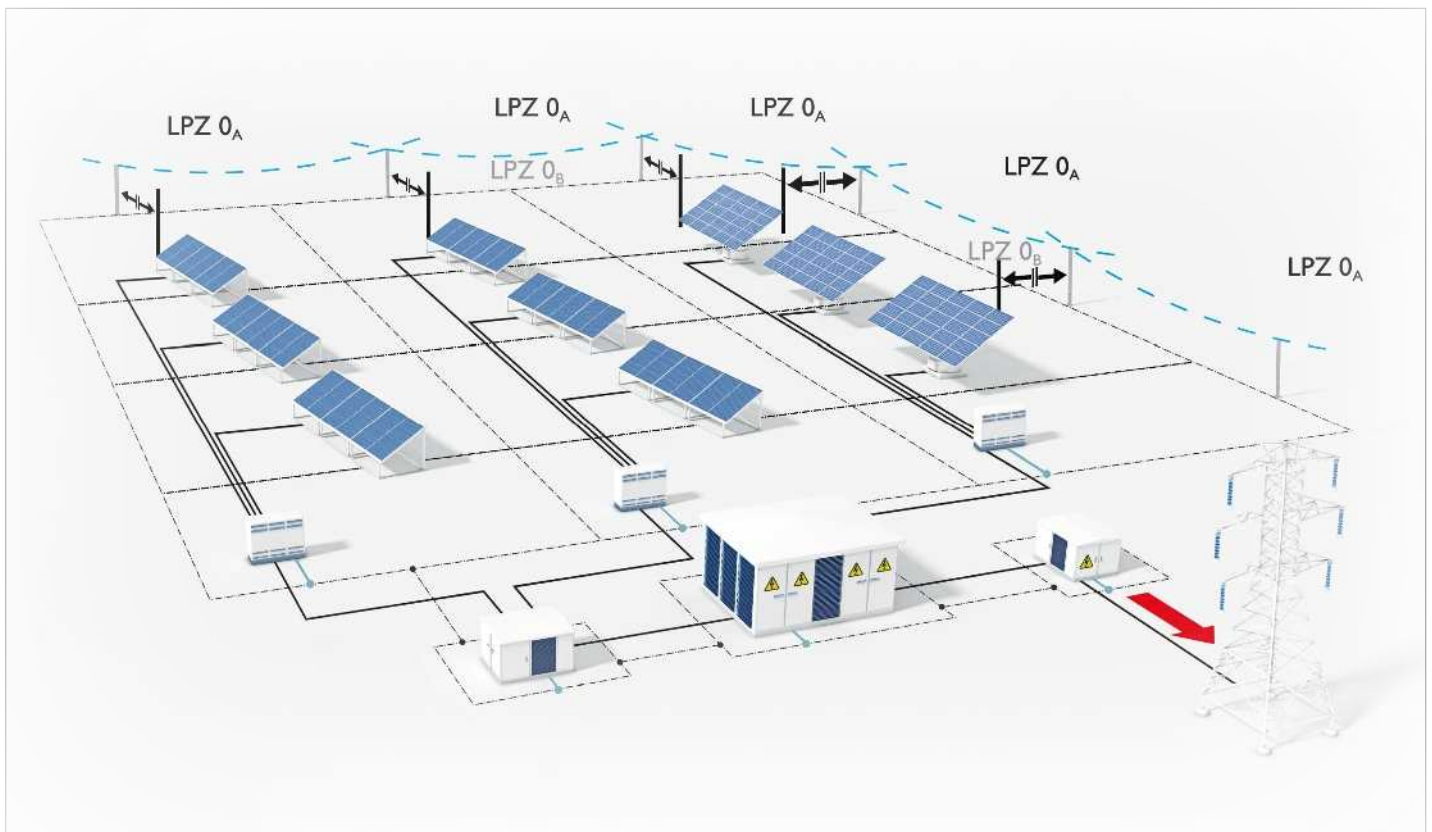

Fig. 71: Free-standing system with external lightning protection system

6.3.2 Free-standing systems

Compared to physical structures, further aspects are relevant for properly designing lightning and surge protection systems for free-standing PV systems:

- Equipotential bonding mesh width
- Design of the grounding system
- Use of inverter types (string or central power inverters)

Free-standing systems are generally characterized by a high intermeshed equipotential bonding system, which is normally equipped with numerous ground

connections. The module frames are also connected to the equipotential bonding system. The cable lengths between the PV panels and the feeding point can be several hundred meters in these systems.

If lightning strikes the external lightning protection system, partial lightning currents are coupled into the equipotential bonding system. Therefore, free-standing systems with central power inverters on the DC side are to be protected using type 1 SPDs, for which the required performance is specified in Table 8.

For free-standing systems with string inverters installed near the PV panels, the following applies:

To protect the AC side, choose SPDs with a discharge capacity analogous to the values in Table 8. To protect the DC side, it is sufficient to use type 2 SPDs with a discharge capacity of at least 5 kA (8/20 μ s) per mode of protection.





Lightning protection class LPL Maximum lightning surge current (10/350 μ s)		SPDs on the DC side I_{imp} in kA (10/350 μ s), I_n in kA (8/20 μ s)							
		Voltage-limiting SPDs			Voltage-switching SPDs				
									
		MOV		MOV + GDT in series		GDT		MOV + GDT parallel	
		$I_{10/350}$		$I_{8/20}$		$I_{10/350}$			
		Per mode of protection	I_{total}	Per mode of protection	I_{total}	Per mode of protection	I_{total}		
III or IV	100 kA	5 kA	10 kA	15 kA	30 kA	10 kA	20 kA		

Table 8: Lightning current parameters ($I_{10/350}$) and I_n ($I_{8/20}$) for SPDs on the DC side in free-standing PV systems with a central power inverter

VALVETRAB-MB-...-DC-PV

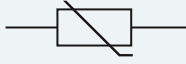
The costs of a PV system can be significantly reduced by a high DC system voltage of up to 1500 V. Fewer string combiner boxes are needed, and material costs for cable installation are also reduced.

With the VAL-MB product range, Phoenix Contact is setting new standards with high-performance SPDs for voltages up to 1500 V DC.

It features a high total discharge capacity I_{total} of 12.5 kA (10/350 μ s) and thereby satisfies all standard requirements and conditions of the installation guideline for use in lightning protection class III and IV.



Fig. 72: VAL-MB-T1/T2 1500DC-PV/2+V-FM

6.4 Protection of signal transmission circuits in MCR technology

Interference-free transmission of signals plays a central role in the field of measurement, control and regulation technology (MCR technology). Smooth operation of building services management, manufacturing or process technology demands a high level of quality and availability of the signals transmitted. However, these technologies are being exposed to an increasingly active electrical environment. This is especially true for the rather weak signals emitted by sensors. Small voltages or electric currents that must be securely transmitted, carefully conditioned or evaluated are increasingly being subjected to electromagnetic and radio frequency interference. Reasons for this are:

- An increasing number of electrically operated components in all performance classes, especially motors operated via frequency inverters and other actuators.
- The increasing miniaturization and packing density of device components.
- A growing volume of wireless communication and control equipment.
- Digital systems that work with ever higher transmission frequencies.

Insufficient consideration of these disturbance variables, inadequate adjustments to remedy faults or other planning deficiencies can all affect interference-free signal transmission.

Surge voltages, such as those caused by the effects of lightning, can also have a negative impact on the function and availability of electronic modules in MCR technology. Interference and damage caused by surge voltages in MCR technology systems can, however, be effectively prevented by using tailor-made protective devices.

Depending on the potential for risk and the requirements of the protection level, surge protective devices with combined protective circuits or with

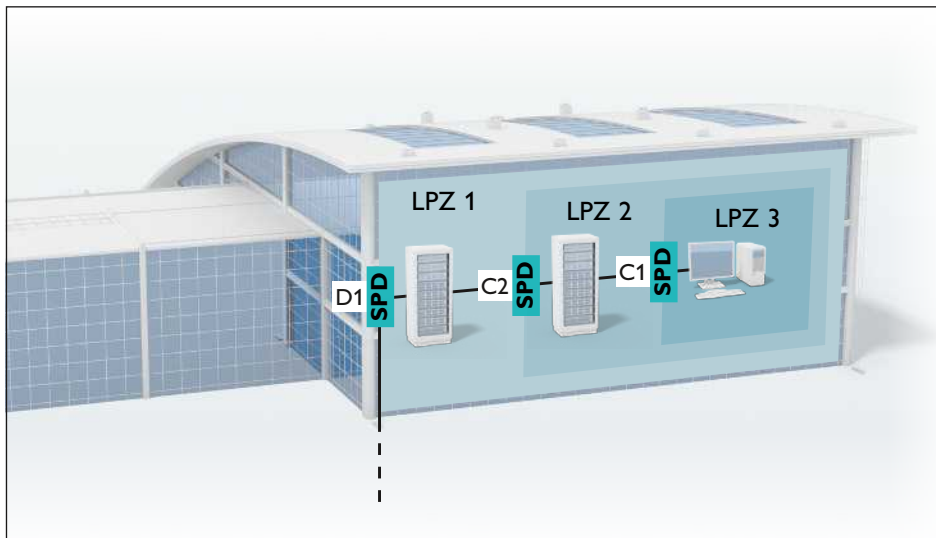

Fig. 73: Lightning protection zones and classification of protective devices for MCR and IT systems in accordance with IEC 61643-22 [16]

individual components are used. These are installed directly upstream of the signal inputs to be protected. The circuits of the surge protective devices to be used are adapted to the various signal types.

6.4.1 Function of surge protective devices

A plethora of different applications and signal forms exist in MCR technology. For this reason, various protective devices specifically tailored to the respective application are necessary. Typical components for these protective devices include gas discharge tubes (GDT) and transient voltage suppressor diodes (TVS diode). Varistors are seldom

used due to their "aging behavior" (increase of leakage current after heavy loading) and larger design.

GDTs consist of an electrode arrangement in a ceramic or glass tube. Inert gas, such as argon or neon, is located between the electrodes. When the strike voltage is reached, the component changes to a low-resistance state as a result of the gas discharge used. The strike voltage is not a constant; rather, it is dependent on the rate of rise of the surge voltage. After igniting the discharge path, arc voltage between 10 and 30 V is typically generated, which can be measured as a voltage drop at the SPD. GDTs have a high surge current discharge capacity of more than ten thousand amperes

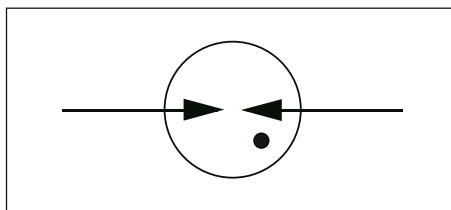

Fig. 74: Graphic symbol of a gas-filled surge arrester

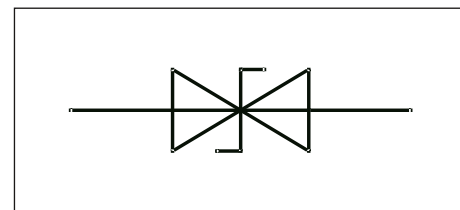

Fig. 75: Graphic symbol of a suppressor diode

(8/20 μ s). With values starting at several hundred volts, however, the voltage protection level is relatively high.

Suppressor diodes become conductive if a voltage threshold or the reverse voltage U_R is exceeded. A current of 1 mA flows through the suppressor diode at the slightly higher breakdown voltage U_{BR} . At this point, the suppressor diode starts limiting the surge voltage. The maximum limit voltage is the highest voltage that can occur at the suppressor diode in the event of surge voltage. The main advantages of TVS diodes are the reaction speed and the exceptional voltage limiting. The surge voltage discharge capacity is significantly lower than that of GDTs, however. Modern protective devices use GDTs and TVS diodes tailored to one another to make best use of their respective benefits. This way, the GDT offers a high discharge capacity and the TVS diode provides a lower voltage protection level and speedy response behavior. Achieving this requires coordinating the coupling elements between the GDT and TVS diode. The way a two-level circuit such as this works is explained in Figure 76. If a transient overvoltage occurs between the signal wires, the TVS diode assumes a low-resistance state after a short response time. This results in a flow of current over the diode and the decoupling elements found in the signal

path R_{total} . The voltage drop is limited to the value of the maximum clamping voltage at the diode and to the value of the voltage protection level U_P at the output terminal of the SPD. The optimal design for conducting current through the SPD features a voltage protection level U_P that is only slightly higher than the maximum clamping voltage. In order to discharge surge currents that exceed the maximum surge current discharge capacity of the TVS diode, the GDT must conduct the portion of the surge current that would otherwise result in an overload of the TVS diode. The current is commutated abruptly in this process after the voltage on the GDT reaches its strike voltage U_Z . When the flow of current is applied, the voltage present at the discharge path sinks to the value of the arc voltage (10 V–30 V depending on the type). The commutation behavior at the protective devices being observed (Fig. 76) is determined mainly by the resistance of the decoupling elements, which is made clear from subsequent observation. The voltage drop U_G at the GDT, which determines its ignition behavior, arises from the voltage drop along the decoupling elements (observation in terms of resistance) and the voltage drop U_S at the TVS diode. From the approximately linear relationship of the previously mentioned voltage drops, it becomes apparent that the voltage drop

at the GDT and, moreover, its response behavior and power conversion in the TVS diode can be specifically controlled by varying the resistance value of the decoupling elements. These positive characteristics linked to the increase of R_{total} are in contrast with the increase of power losses in the decoupling elements (resistances). An upper limit for the rated current of the SPD is derived from the self-heating, connected with the need to comply with maximum temperatures.

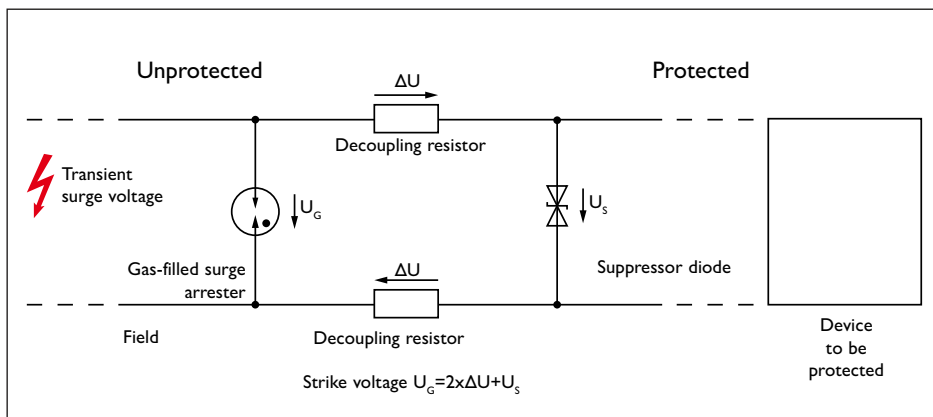

Fig. 76: Two-stage protective circuit

Basic circuits

Various protective circuits tailored to individual applications are available for MCR technology. First of all, a distinction is made between signal types that are designed as an independent closed circle (loop) and signals with a common reference potential or a shared return conductor. The independent closed circuits (loops) are often designed so that they are insulated from the ground potential for interference immunity. A frequently encountered application of this type is the 4 to 20 mA current loop for transmitting measured values. The SPDs are designed to ensure continued insulation in the application. Gas discharge tubes guarantee insulation between the signal wires and the ground potential during operation. In the event of surge voltage, the GDT effectively discharges the transients

to ground and limits the voltage so that the dielectric strength of the end device is not exceeded. Typical dielectric strength of end devices is 1.5 kV. In addition to protecting the dielectric strength, protection between signal wires is especially important for MCR applications in order to prevent exceeding the electric strength. The end devices are often much more sensitive to potential differences of this nature, as sensitive semiconductor components in the end device are directly affected. Often, the corresponding electric strength of the devices is below 100 V. The protection level reached by the SPD therefore consists of a fast-response TVS diode that implements a correspondingly low voltage protection level.

In cases where the decoupling resistors in the common mode paths are not reliable, a version of the circuit

without decoupling is needed. This can be the case with Pt 100 two-conductor measuring circuits in which the resistors can distort the measuring result. Even for actuator circuits with higher nominal currents, this type of protective circuit is used. A lower surge current discharge capacity between the signal wires nonetheless results if there is no decoupling present.

Applications with a common reference potential require a specially designed protective circuit, as the sensitive semiconductor components in the end devices can also be damaged by transient overvoltages between the signal wires and the reference potential. For this reason, in such cases the TVS diodes are switched between each wire and the reference potential. In cases where the reference potential is grounded, the SPD can be used, as

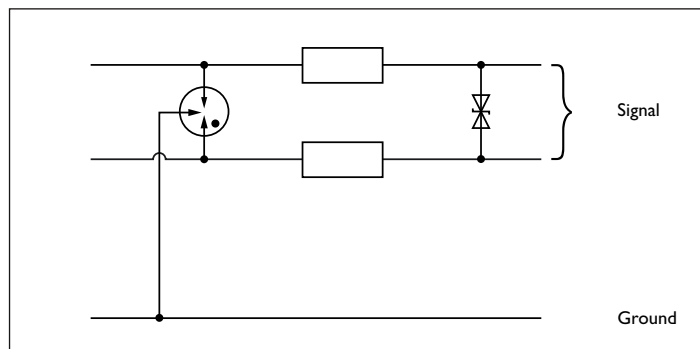

Fig. 77: Basic circuit for insulated signal circuits

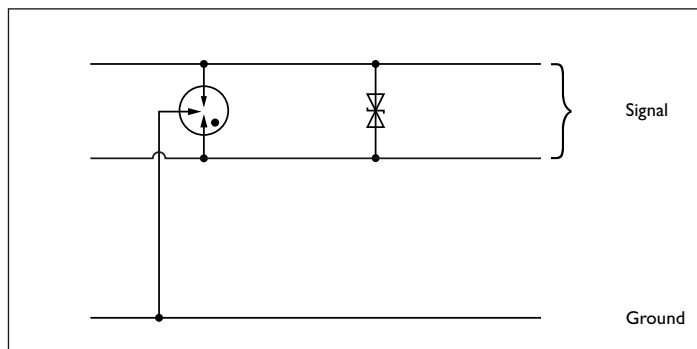

Fig. 78: Basic circuit for insulated signal circuits (without coupling resistors)

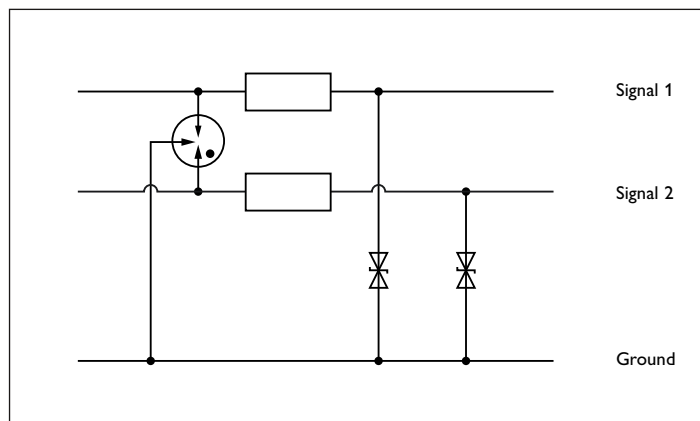

Fig. 79: Basic circuit for applications with common reference potential, directly grounded

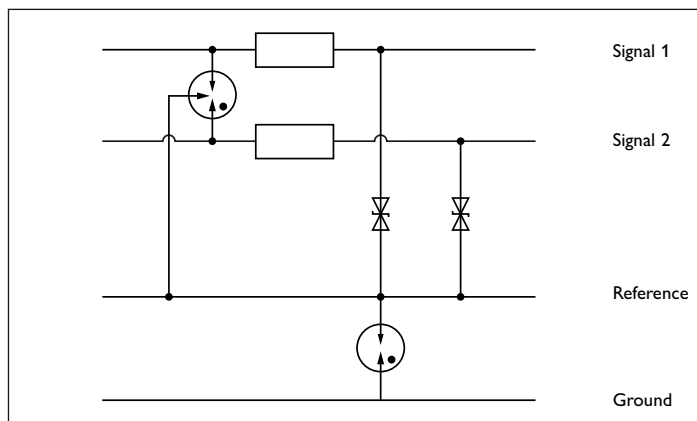

Fig. 80: Basic circuit for applications with common reference potential, indirectly grounded

shown in Fig. 79. In the majority of cases, a direct connection between the common reference potential (e.g. ground) and the ground potential is not permitted or desired. Circuit versions with an additional GDT between the reference potential and the ground are used for this application. (Fig. 80). This is referred to as indirect grounding.

6.4.2 Protection zone concept in MCR applications

The necessity for implementing surge protection is determined based on a risk analysis. SPDs are then selected using the test class prescribed by the zone transition (see Fig. 81). In order to attain the ideal optimal protective effect, the SPDs are each to be placed at the zone limits. All cables that lead into or out of the building are to be integrated into the common equipotential bonding by the corresponding SPDs. In particular, the zone concept is to be applied if there is an external lightning protection system. For example, the first protection level (j, l) primarily offers protection against destruction for installation directly at the entrance to the building. The SPDs used are to be rated according to the expected level of threat. Subsequent SPDs (k,n and m,o) then only need to reduce the interference voltages and surge currents to a value acceptable for the end device. In contrast to the SPD installation for power supply systems, an SPD must be installed at every

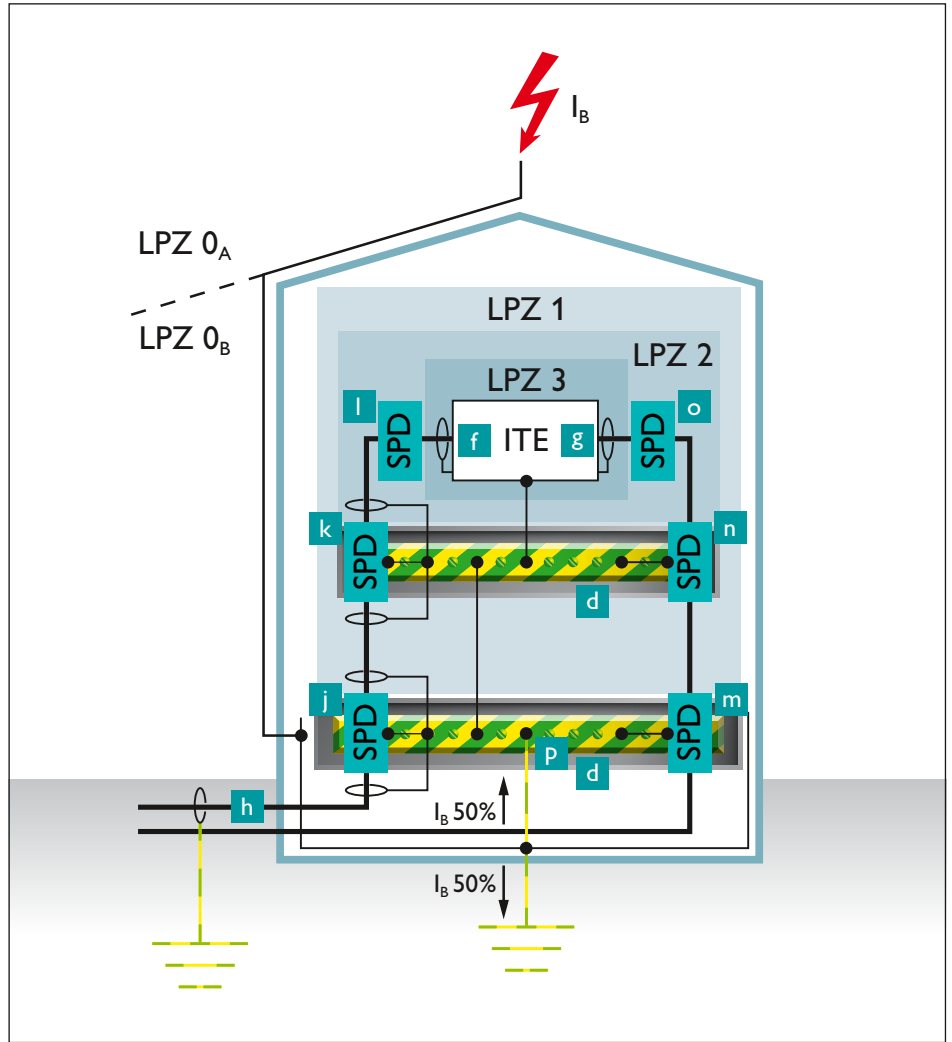

Fig. 81: Zone concept in accordance with IEC 61643-22 [16]

zone transition for MCR signals (see IEC 61643-22, [16]).

In practice, the choice is made to not separate the signal cables from the field at each zone transition. This keeps the cost of installation low. Multiple protection levels are therefore combined in one MCR SPD. As a practical solution, this protective module can be installed upstream of the device to be protected, such as the inputs of a controller. Compared to SPDs for power supply in accordance with IEC 61643-11, the distinction here is not made according to T1, T2, T3; rather, the SPDs are classified according to discharge capacity. D1 for lightning signals at the LPZ 0/1 zone limit, C2 for reduced noise pulses at LPZ 1/2 and C1 at LPZ 2/3. The

selection list (Table 9) from DIN CLC/TS 61643-22 [16] provides information about the location at which each SPD type must be installed.

Zone transition	0 _A → 1	1 → 2	2 → 3
SPD type corresponding to IEC-61643-21	D1	C2	C1
SPD type corresponding to IEC-61643-11	1	2	3

Table 9: Lightning protection zone transitions and corresponding SPD types

Surge protection for current loops

Measured values are usually transmitted using standardized processes in the field. The 4 to 20 mA signal is used especially often for applications where longer cables are in use. The measured value at the sensor is converted into a current value that runs between both transmission devices. The ohmic resistance of the cable has no influence here on the current of the measured value transmission. For current loops, two signal wires are often used which do not require an additional reference potential and are routed in an insulated state from the ground potential. In order to protect an application of this kind from transients, an SPD is needed at both end points. The respective SPD is equipped with a multi-stage protective circuit. Transient normal-mode voltages between signal wires and common-mode voltages to ground are effectively limited at both end points as a result (see Fig. 82).

Surge protection for binary signals

In control technology, modules are often used that feature a higher number of signal inputs and outputs (digital in/digital out). Furthermore, there is a common reference potential that is often simultaneously used as a common return conductor from the field. The protective circuit suitable for this type

of application is designed with two protection levels between each wire and the common reference potential. Between two "neighboring" signal wires, there is always protection through series connection of two suppressor diodes. Moreover, there is protection to the ground via a GDT so that, together, all conceivable transients are limited (see Fig. 83).

Surge protection for temperature measurements

If a temperature measurement is taken using a temperature-dependent resistor, like Pt 100, the ohmic portion of the additional cables as well as the decoupling resistors of surge protective devices specifically need to be taken into account. In the case of two-wire measurement, the resistance value of the SPD can distort the measured result. If the sum of the decoupling resistances in the measured circuit is, for example, 4 ohms, there is then a measuring error of 4% for a measurement of 0°C, as instead of 100 ohms, 104 ohms is detected. For this reason, the two-stage protective circuits are available as a version without decoupling resistors in order to minimize the influence of the SPD in this application (see Fig. 84).

Surge protection in explosion-protected areas

Explosive atmospheres can frequently occur in the chemical and petrochemical industries due to industrial processes. They are caused, for example, by gases, fumes or vapors. Explosive atmospheres are also likely to occur in mills, silos, and sugar and fodder factories due to the dust present there. Therefore, electrical devices in potentially explosive areas are subject to special directives. This also applies to SPDs that are used in these types of applications.

Potentially explosive areas are divided into standardized zones. Classification for explosive dust and gas zones is found in the standard IEC/EN 60079-11 [17]. Zones are classified based on the probability that an explosive atmosphere will arise.

The Ex i intrinsic safety type of protection is used often in the field of MCR technology. Intrinsic safety protection, as opposed to other types of protection (such as increased safety), refers not only to individual items of equipment but to the entire circuit. A circuit is described as intrinsically safe if the current and voltage are limited to such an extent that no spark or thermal effect can cause an explosive atmosphere to ignite. The voltage is limited in order to keep the energy of the spark below the ignition energy of

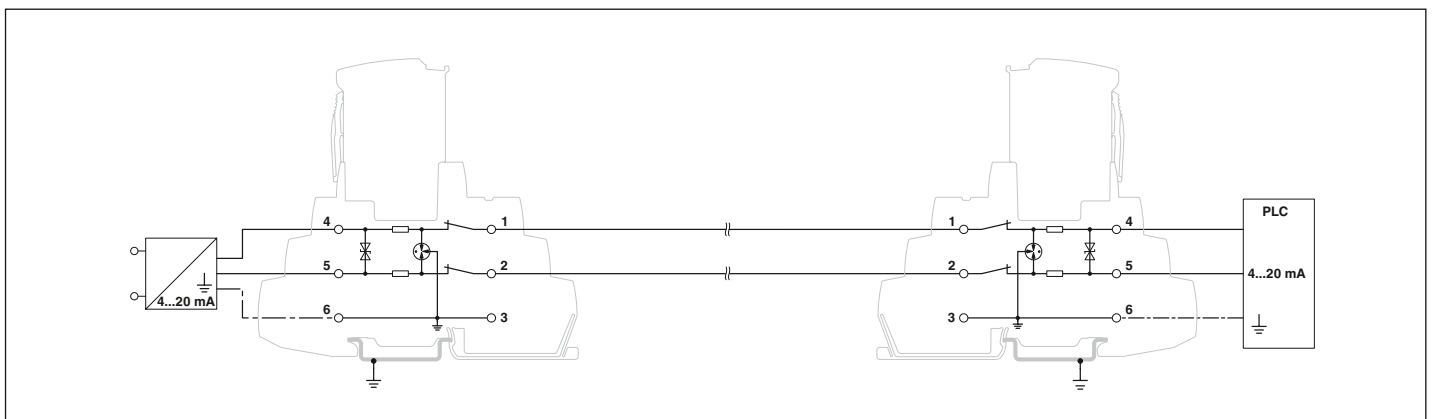

Fig. 82: Example of a measuring signal transmission (4...20 mA) with surge protection

the surrounding gas. A thermal effect, such as a surface that is too hot, is prevented by limiting the current. Energy may also be stored in the form of capacitances or inductances within the intrinsically safe circuit. This must also be taken into consideration when examining the intrinsically safe circuit. Safety level ia, ib or ic defines whether protection is maintained with two faults or one fault in the protective circuit, or whether no protection is provided in the event of a fault. Intrinsic safety is based on fault monitoring in order to rule out an explosion hazard. In relation to the surge protection of intrinsically safe circuits, it is important to ensure that a corresponding Ex i approval is present. Furthermore, the SPD must be able to discharge at least 10 signals of a surge

current of 10 kA (8/20 μ s) safely. The comprehensive description of explosion protection measures in connection with the intrinsic safety type of protection can be found in the standard IEC/EN 60079-11 [17].

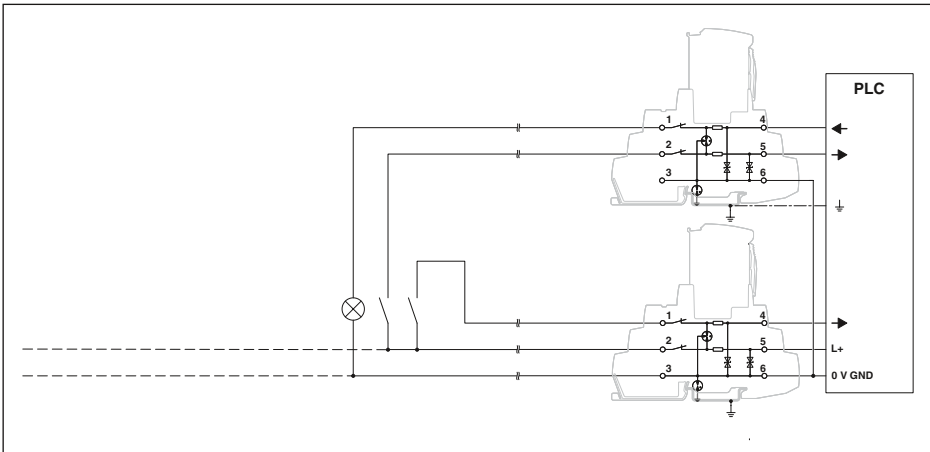

Fig. 83: Example of protected binary inputs and outputs of a controller

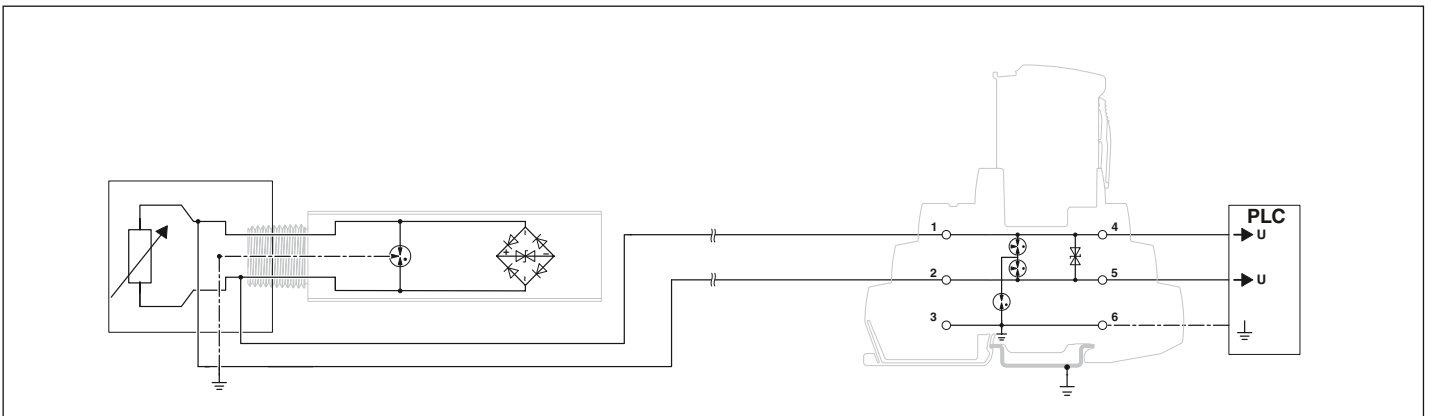

Fig. 84: Example of protected two-wire temperature measurement (Pt 100)

Zone 0

Area in which a hazardous explosive gas atmosphere is present for continuous, frequent or long periods. These conditions are usually found inside containers, pipelines, equipment and tanks.

Zone 1

Area in which a hazardous explosive gas atmosphere is to be expected only occasionally during normal operation. This includes the immediate area surrounding zone 0, as well as areas close to filling and emptying equipment.

Zone 2

Area in which a hazardous explosive gas atmosphere is not expected during normal operation; however if it does occur, it is only for a short time. Zone 2 includes areas that are used exclusively for storage, areas around pipe connections that can be disconnected and generally the intermediate area surrounding zone 1.

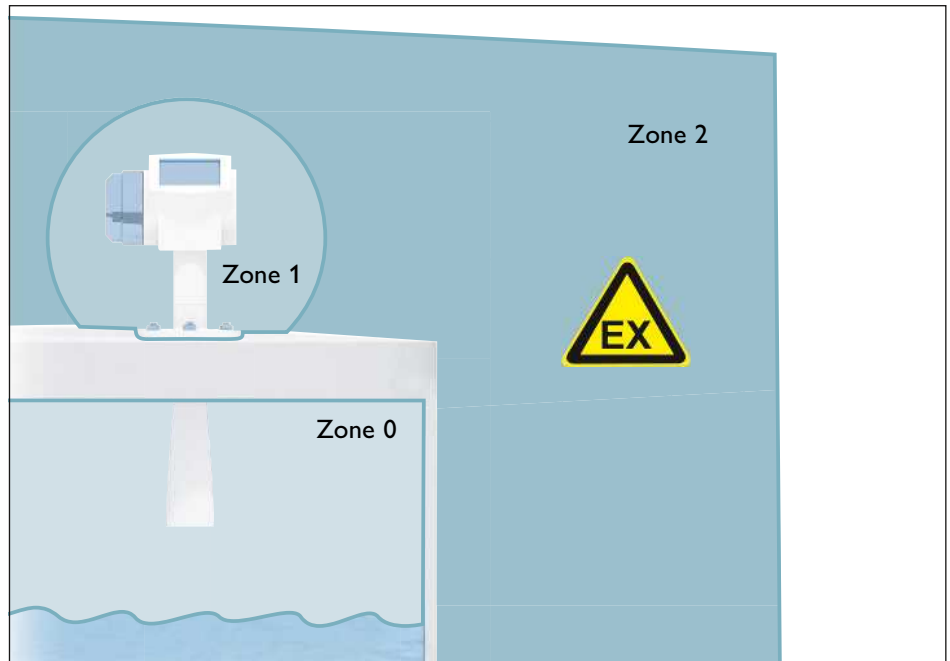

Fig. 85: Zone division based on the example of a liquid tank with fill level sensor



Fig. 86: TERMITRAB complete for protecting intrinsically safe circuits

Certified protective devices for potentially explosive areas

With the TERMITRAB complete, PLUGTRAB IQ and SURGETRAB product ranges, Phoenix Contact provides solutions that have ATEX approval in accordance with the directive 94/9/EC and that can be installed in intrinsically safe circuits up to Ex-zone 1.

Since all SPDs from Phoenix Contact for intrinsically safe circuits are classified in the "Ex ia" category, they offer the highest level of safety. In the "ia" category, an intrinsically safe circuit in an electrical device must not be capable of causing ignition in the event of voltages U_m and U_i , even under the assumption of two unrelated faults.

6.4.3 Selecting SPDs for MCR systems

There is a great variety of surge protective devices in the field of MCR technology. The selection criteria range from the obvious installation characteristics of the SPD and advantageous product features to the technical parameters of the application.

Installation characteristics

a) Mounting type

SPDs are installed on the DIN rail as standard. For installing SPDs on field devices, it is sometimes easier to screw the SPD directly onto the sensor head.

b) Connection technology

Many SPDs feature the familiar screw connection. As many wires are connected in MCR technology applications, the quicker, tool-free Push-in connection is preferred.

c) Overall width

The number of signals to be protected in an MCR application is often very large. A narrower SPD can therefore contribute considerably to allowing the entire control cabinet to be dimensioned in a smaller form.

Product features

d) Signaling and remote signaling

Overloaded SPDs no longer offer protection and must be replaced. A failed device can be detected with the aid of a status indicator on the SPD. Optional remote signaling makes it possible to transmit the status to the control room and replace the SPDs quickly. Remote signaling increases the quality of protection for the overall surge protection concept.

e) Pluggability

Pluggable SPDs can be replaced without accessing the installation. The signal is neither interrupted nor affected during plugging and disconnecting.

f) Knife disconnection

SPDs with knife disconnection offer the possibility of opening the signal path on the SPD. This way, SPD wiring to the field can be separated from wiring to the electronics. Maintenance work also becomes exceptionally simple, such as conducting insulation measurements to identify a fault in the field cabling, for instance.

Application parameters

g) Interface type

A distinction is generally made between interface types with and without reference conductors. Signals with reference conductors, e.g. digital signal inputs, require coarse and fine protection elements between the signal wire and reference conductor. Signals without reference conductors, e.g. 4 to 20 mA current loops, require a fine protection element between both signal wires, as this is where the sensitive electronics are installed, and coarse protection to the ground potential. The protective circuits are to be selected for the SPDs accordingly.

h) Nominal voltage

The nominal voltage of the application has a significant influence on the surge voltage resistance of the end device. As a rule, the lower the nominal voltage of the application is, the lower the voltage protection level of the SPD should be. The maximum voltage of the application may not exceed the highest continuous voltage U_c of the SPD, however, as it can otherwise lead to an overload.

i) Rated current

The rated current of SPDs for MCR technology is limited by the type of protective circuit. Since the nominal current in MCR technology is generally low, a low SPD rated current is sufficient in many cases. The protective circuit must be varied for applications with higher nominal currents. As a rule, the nominal current of the application is not allowed to exceed the rated current of the SPD.

j) Number of signal wires

A separate SPD can generally be used for any pair of signal wires. In order to increase the packing density, SPDs that protect multiple signal wires are useful, e.g. two digital inputs with one common reference conductor.

Online configurator for MCR surge protection

Assessing all selection criteria individually can be tedious. The online configurator from Phoenix Contact offers a simple option for selecting the suitable SPD for the respective MCR application. The configurator takes the technical suitability of the SPD into account in this process. Desired product characteristics can be added with ease and unnecessary product characteristics can be removed. As a result, the process of selecting a product is simplified considerably with this straightforward approach.



Web code: #1389

k) RF application or data interface (>1 Mbps)

Many surge protection circuits have a low-pass characteristic. Therefore, for radio-frequency applications, protective circuits are required where the signal attenuation is barely noticeable.

l) Resistance-dependent measurement

In protective circuits commonly implemented for MCR technology, decoupling resistors are used in the signal path that serve to coordinate between fine and coarse protection elements. Circuits are available for resistance-dependent measurements which do not influence the impedance of the signal path.

m) Ex application

In applications with potentially explosive atmospheres, increased requirements are placed on electrical devices. SPDs with the corresponding characteristics and approvals are necessary for these applications.

n) Protective circuit type

Multi-stage protective circuits that contain coarse and fine protection elements are used as standard. These circuits offer lightning and surge protection and can therefore be universally implemented. One-stage circuits have a simpler design but offer either only lightning or only surge protection.

Installation characteristics	Application parameters
Mounting type	Interface type
Connection technology	Nominal voltage
Overall width	Rated current
	Number of signal wires
Product features	RF application or data interface (> 1 Mbps)
Signaling and remote signaling	Resistance-dependent measurement
Pluggability	Ex application
Knife disconnection	Protective circuit type

Table 10: Selection criteria for MCR SPDs

6.4.4 Surge protection in thin layers – TERMITRAB complete

SPDs with high packing density are often required in MCR technology, since many signals may need to be protected in a single control cabinet in the process industry for example. By using especially narrow SPDs like TERMITRAB complete, space requirements can be significantly reduced and systems can be dimensioned in a smaller form.

Status indicator and remote signaling

Surge protective devices can be overloaded and experience failure. For a long-lasting, functional surge protection concept, it is crucial that overloaded SPDs be detected and replaced. To that end, TERMITRAB complete offers mechanical status indicators on the module that signal when a surge protection component is disconnected from the signal path. The status indicator

functions without additional auxiliary power. The status of the TERMITRAB complete modules can be transmitted to the control room, thanks to the optional remote signaling modules. This means information is always available via a functional surge protection system. A remote signaling module monitors the status of up to 40 neighboring TERMITRAB complete modules. For this reason, no additional wiring or programming is necessary. If a protection element is disconnected in the event of an overload, the disconnected device closes the monitoring channel and group remote signaling is triggered.

Tailored portfolio

TERMITRAB complete offers a tailored portfolio with various functions. Starting with simple terminals with one surge protection component, the range expands to include multi-stage, pluggable SPDs with status indicators and integrated knife disconnection. This makes it possible to create a concept

with the desired product characteristics based on the individual requirements. A suitable circuit and the optional functions are selected in just a few steps using the online configurator.



Fig. 87: Surge protection for all applications – TERMITRAB complete

TERMITRAB complete – ultra narrow

The TERMITRAB complete TTC product range includes the smallest surge protection device in the world for MCR technology at an overall width of just 3.5 mm. This saves space and cuts costs.

- 3.5 mm overall width
- Push-in connection technology
- Multi-stage protective circuit
- Digital and analog signals

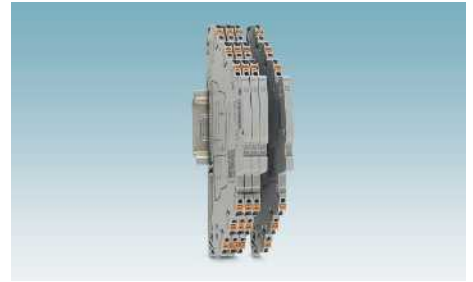

Fig. 88: TTC-3

TERMITRAB complete – narrow and pluggable

Also among the pluggable varieties, TERMITRAB complete offers the narrowest solutions on the market with an overall width of 6 mm.

- 6 mm overall width
- Can be plugged in and tested
- Integrated status indicator
- Available with knife disconnection
- Push-in or screw connection
- Multi-stage protective circuit



Fig. 89: TTC-6 pluggable versions

TERMITRAB complete – one-piece

If there is no need to plug and test the devices, the one-piece versions are the suitable alternative from the TERMITRAB complete system.

- 6 mm overall width
- Available with integrated status indicator and knife disconnection
- Push-in or screw connection
- Multi-stage protective circuit



Fig. 90: TTC-6 one-piece versions

TERMITRAB complete – one-stage

The only one-stage protection element on the market with an integrated status indicator and optional remote signaling.

- 6 mm overall width
- Integrated status indicator
- Push-in or screw connection
- One-stage protective circuit



Fig. 91: TTC-6 one-stage versions

TERMITRAB complete – remote signaling

Sender and receiver module for monitoring up to 40 protective devices from the TERMITRAB complete range.

- 6 mm overall width
- Integrated status indicator
- Push-in or screw connection
- Floating remote indication contact
- No wiring of individual protective devices

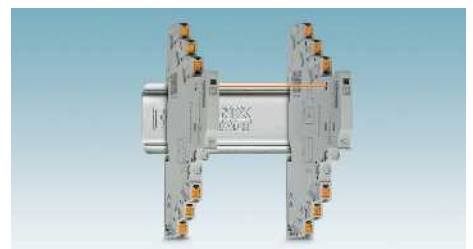

Fig. 92: TTC-6 remote signaling set

6.4.5 Surge protection with early detection

Monitoring protection elements combined with a remote signaling function is especially useful for protective devices in difficult to reach locations. A status-oriented, even preemptive maintenance strategy is possible, thanks to the continuous status acquisition and evaluation of aging indicators. Relating to the observed components of the TVS diode and GDT of the protective circuit, the methods described below, based on physical and statistical principles as well as the links between the two, can be used to detect the state of the component and the evaluation of aging processes.

a) A "direct" evaluation of the component state, i.e. a direct physical evaluation, is possible if there is a direct relationship between the measured variables and the aging state to be detected. This kind of physical relationship exists, for example, between the leakage current generated by a TVS diode and the extent of its damage.

b) Statistical evaluation procedures are used if there is established knowledge on the load-dependent aging and failure behavior for the observed component. In this case, statistical statements can be made about the state by detecting the load and comparing it with load limits described in IEC 61643-21 [7]. Here,

for example, the visual detection of gas discharge associated with a flow of current through the GDT is useful.

The visual detection of the flow of current through the GDT and detection of leakage current through the TVS diode are used for the technical implementation of state acquisition and evaluation for a 2-stage protective circuit. By collecting these measured variables, it is possible to make statements regarding prior component loads and physical component parameter changes continuously using suitable algorithms. This information is displayed via a status message. In order to provide the option of retrieving this information in a control room, for example, it is advantageous if the protection state can be signaled remotely. For this purpose, a floating contact that can be evaluated by a PLC is often used on the protective device. The result can then be forwarded to the control room using various transmission media (bus or wireless systems). Optional status detection and processing has been implemented in the PLUGTRAB PT-IQ protective device system (Fig. 93). The respective function status is reported by an intelligent monitoring system. There are LED indicators on the protective plug in green, yellow and red for this purpose. Yellow indicates that the protective device is nearing the end of its service life. However, yellow also means that the protective function is still fully guaranteed. This early warning indicator

makes it possible to plan replacement at an early stage. A replacement is recommended and must be carried out when the red LED lights up at the latest.

In order to minimize product wiring costs, a signal and supply bus runs along the DIN rail. The protection modules also contain the supply voltage and report their status to the central supply and remote signaling module (PT-IQ-PTB), which visually displays the signal and makes it available as a remote signal via a floating contact. Using this floating contact, the status of the SPDs can be forwarded using various transmission media (bus or wireless systems).



Fig. 93: Protective device system PT-IQ with function indicator display

PLUGTRAB PT-IQ

This intelligent monitoring system allows the user to know the protection status of the system at any time, regardless of location. A preemptive maintenance strategy is also possible, thanks to the three-stage display. The devices are available with screw terminal blocks or with a Push-in connection. The wiring costs of the products are minimized, thanks to a signal and supply bus located in the DIN rail. Furthermore, there are versions for use in Ex i circuits.

6.4.6 Surge protection at the field device

In order to protect field devices, SPD designs are available that can be easily installed on the objects to be protected. A free cable gland is utilized in this process and the SPD is connected with parallel wiring. If there is no free gland remaining on the field device, an SPD version with through wiring can be used.

SURGETRAB

This item range is designed especially for use in the field. Different circuit versions are optimized for measuring circuits and actuators. Screw connections with metric threads or 1/2" and 3/4" allow for use in all field device systems available around the world.



Fig. 94: SURGETRAB with through wiring on the field device



Fig. 95: SURGETRAB with parallel wiring on a field device

6.4.7 Lightning protection equipotential bonding for pipelines

A long service life is vital for the cost-effective operation of pipelines. Active corrosion protection systems are used to protect against rust. In operation, these require the metal pipes be

insulated to the ground potential. In order to protect the pipe insulation (coating) and the insulating flanges against damage caused by surge voltages, isolating spark gaps are used. If a surge voltage occurs, for example due to a lightning strike, the isolating spark gap becomes low-resistance. The lightning surge current is discharged to ground

on a defined path. Lightning protection equipotential bonding is thereby guaranteed.



Fig. 96: Typical application field: gas compression station



Fig. 97: Installation example based on an insulated flange

6.5 Protection of signal transmission circuits in information technology

Communication via data networks is a part of daily life in all areas of business.

The interfaces operate with low signal levels at high frequencies. This makes them particularly sensitive to surge voltages and can lead to the destruction of electronic components in IT systems. In addition to protection that is tailored to these systems, SPDs must also exhibit high-quality signal transmission behavior, as otherwise malfunctions are to be expected in the data transmission. This aspect is becoming increasingly important in the face of constantly increasing data transmission rates. To this end, when developing new SPDs for IT systems, the focus is on implementing high-quality signal transmission behavior. It is evaluated based on the ISO/IEC 11801 or EN 50173 standards.

Furthermore, a wide range of connection technology is seen in this area of application. For this reason, the protective devices must correspond to the electrical specifications and also be adapted to the interfaces to be protected. The SPD versions often differ only in their design and connection technology.

The protective circuits usually combine fast-responding, low-capacitive suppressor diodes with powerful gas discharge tubes. Where required by

the circuit technology, ohmic resistors decouple the two protection stages.

6.5.1 Ethernet and token ring interface

The architecture or structure of a network installation and the type of data transfer between the terminals in the data network are referred to as the topology.

In local networks, they have been tried and tested as bus, ring, and star topologies that can also be combined. To transmit information in data networks, twisted pair or fiber optics are used.

Data transmission requirements

Ethernet and token ring interfaces have been used for years. Ethernet systems have prevailed, however, due to their transmission speed and compact connectors. The transmission behavior of the Ethernet system is defined in standard IEEE 802.3. The transmission speed is up to 10 Gbps.

The transmission speed is defined (Table 11) depending on the performance categories (cat. 5 - cat. 7).

Newer systems with high transmission frequency requirements function in accordance with cat. 6 and cat. 7, and eventually cat. 8.1 or cat. 8.2.

Protective devices with RJ45 connection, where all eight signal paths are protected, are universally suited to the Ethernet, PROFINET and token ring interfaces.

Power over Ethernet (PoE)

Power over Ethernet (PoE) is a process in which the auxiliary energy for the connected devices is also transmitted via the Ethernet data cable.

The auxiliary power is applied either to the unused wire pairs (mode B, Fig. 100) or fed as phantom power (mode A, Fig. 99) between the signal wire pairs. In line with IEEE 802.3af, a maximum power of 13.5 W can be transmitted using this method. The subsequent IEEE 802.3at standard now allows 25.5 W with PoE+. PoE++ is being debated, which will make it possible to achieve even higher transmission capacities.

6.5.2 Serial interfaces

Serial interfaces allow for data exchange between computers and peripheral devices. During serial data transmission, the bits are transmitted over a cable (in series), one after the other. Particularly common are:

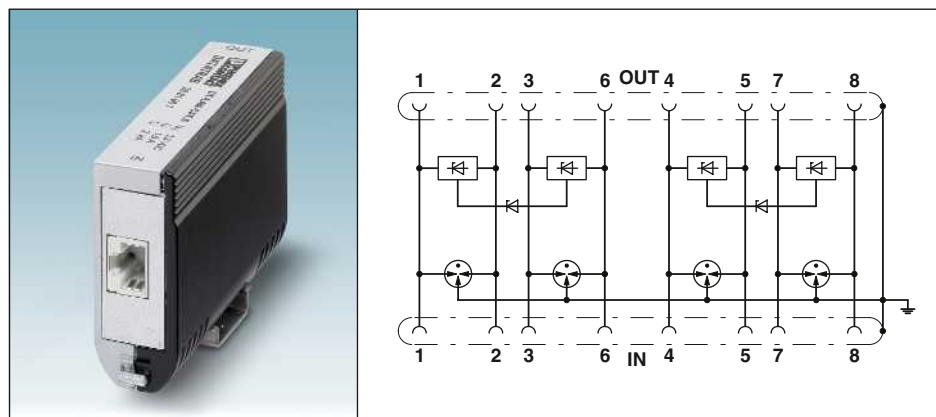

Fig. 98: DT-LAN-Cat.6+ - SPD for information technology

DT-LAN-Cat.6+

The DT-LAN-CAT.6+ protective device optimally protects sensitive equipment, as quickly reacting protective components are used for the data cabling as well as for the PoE system.

	Area of application	Category	Mbps	Cable	Connection
100 Base TX (Fast Ethernet)	LAN, structured building cabling	5	100	2- ... 4-pair twisted pair	RJ45, pairs: 1-2, 3-6, or 4-5, 7-8
1000 Base T (Gigabit Ethernet)	LAN, structured building cabling	5e, 6	1000	4-pair twisted pair	RJ45, pairs: 1-2, 3-6, + 4-5, 7-8
10 GBase T (Gigabit Ethernet)	LAN, structured building cabling	6a	10,000	4-pair twisted pair	RJ45, pairs: 1-2, 3-6, + 4-5, 7-8
10 GBase T (Gigabit Ethernet)	LAN, structured building cabling	7	10,000	4-pair twisted pair	RJ45, pairs: 1-2, 3-6, + 4-5, 7-8

Table 11: Transmission speed vs. performance categories

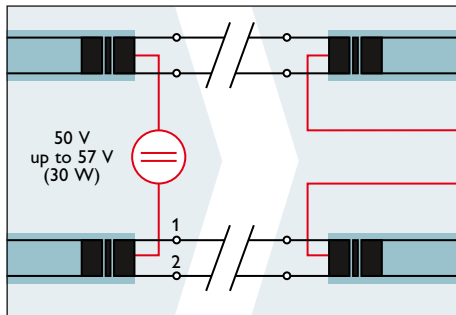

Fig. 99: Transmission of auxiliary power by means of phantom supply (mode A)

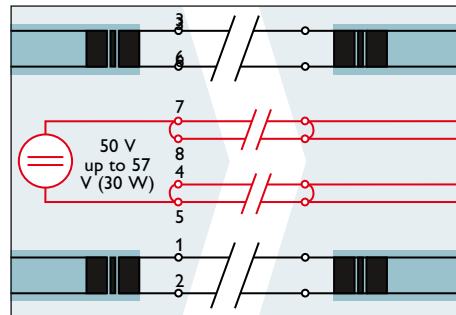

Fig. 100: Transmission of auxiliary energy via free wire pairs (mode B)

is routed as a reference potential, so that defined voltage conditions prevail at the connected interfaces.

TTY interface

The TTY interface works serially and symmetrically via two signal wire pairs. When a signal voltage of up to 24 V occurs, a current signal is analyzed. Here, 10 to 30 mA is the logical 1 and 0 to 1 mA is the logical 0. Standard data transmission rates are 9.6 or 19.2 kbps.

RS-485 and PROFIBUS interfaces

The RS-485 serial interface is used on the Intel bitbus and is closely related to RS-422. This symmetrical data transmission generally functions via a pair of signal wires. Versions with two pairs of signal wires and a ground are also used.

In older systems, the signal voltage of this interface amounts to ground -7 V and +12 V. In newer systems, a version with TTL level, i.e. +/- 5 V, is used.

The PROFIBUS interface is a further development of the RS-485 interface. It uses the physical characteristics of the RS-485, but with transmission rates of up to 12 Mbps. These interfaces are used for other applications in the time and machine data acquisition device field.

D-SUB attachment plugs for DIN rail mounting or DIN rail modules with screw terminal blocks are frequently

used as protective devices.

V.24 interface

The serial interface V.24 or RS-232 works with an asymmetrical signal transmission. One transmit and one receive signal each have a common reference potential (ground). In addition, up to five control signals can be transmitted. This yields a maximum of eight active signals including ground. Connection is usually implemented via D-SUB 25, D-SUB 9 or screw terminal blocks.

V.11 interface

The serial interface V.11 or RS-422 works on the basis of symmetrical signal transmission. The transmission path can be up to 1000 m. The transmit and receive signal are each transmitted via a pair of signal wires. In addition, a ground

6.6 Protection of signal transmission circuits in telecommunications technology

Telecommunication end devices are today an inherent part of office electronics. Today, unrestricted operational availability of modern, fast communication systems is an absolute necessity, especially in the business sector. The specific use of suitable surge protective devices can prevent the sudden and unforeseen failure of important telecommunications equipment. Suitable protective devices for DSL data transmission and for analog signal interfaces are available.

The protective circuit is mainly made up of a combination of diodes and powerful gas discharge tubes. The gas discharge tubes are designed as three-electrode gas surge protective devices. The central electrode provides common-mode voltage protection at the ground potential. Where required by the circuit technology, ohmic resistors decouple the two protection stages. To protect against voltages from the power supply network (power cross) the three-electrode gas discharge tubes are equipped with thermal protection.

6.6.1 Interfaces in telecommunications

xDSL interface

DSL interfaces (digital subscriber line) provide Internet connections with speeds of 1 Mbps (ADSL) to 100 Mbps (VDSL). The transmission frequency is between 2.2 and 17.7 MHz. The nominal voltage for the protective circuit on suitable protective devices depends on whether a DC supply is also transmitted. Typical nominal voltage values for applications are:

- Without power supply: <24 VDC
- With power supply: ≥ 110 V DC

When compared internationally, the transmission frequency in the DSL range can vary by some 100 kHz depending on the region. For this reason, their cut-off frequency should be taken into account when selecting a protective device.

Analog telecommunications interface

Today, analog telecommunication is only found in simple telephone connections. Protective devices for this should have nominal voltages of 180 V. Generally, DSL protective devices (Fig. 101) can also be used for analog telecommunication.

6.6.2 Connection technology

LSA-PLUS technology has been in use as connection technology for many years. It is an insulation displacement contact that individually presses the wires of a cable along with insulation using a special tool known as a punch-down tool. Protective modules can be plugged into these LSA-PLUS strips easily, without the use of tools. Coarse protection magazines (with GDT) or modular miniature plugs with combined coarse and fine protection elements (Fig. 102) are available for protection.



Fig. 102: COMTRAB: Modular, small and simple

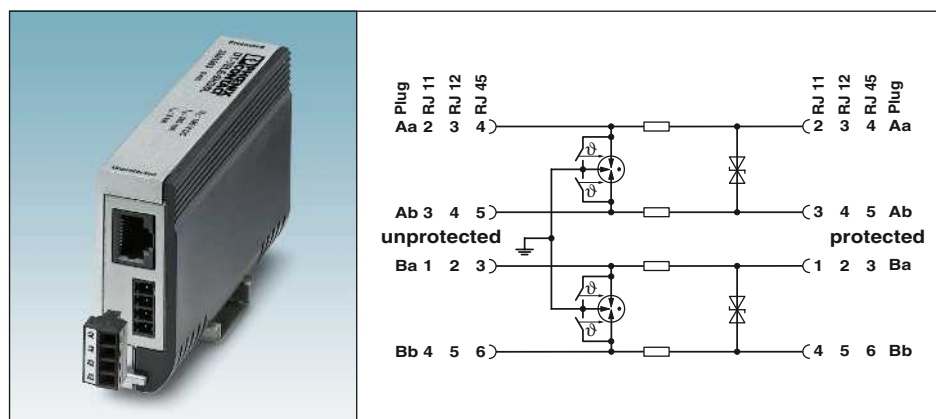

Fig 101: DT-TELE-RJ45 - SPD for telecommunications systems

DT-TELE-RJ45

The DT-TELE-RJ45 protective device protects fast VDSL connections, thanks to its exceptionally low attenuation. Thanks to the universal connection technology (RJ45, RJ12, RJ11, and pluggable screw connection) the product is ideal for any application.

6.7 Protection of signal transmission circuits in transceiver systems

Transceiver systems are generally considered to be particularly susceptible to surge voltages.

Antenna cables which extend beyond the building and are generally particularly long, as well as the antennas themselves, are directly exposed to atmospheric discharges. For this reason, cables with a coaxial design and associated favorable EMC properties are used. The shield of the antenna cable can be either grounded or floating, depending on the system conditions. However, the risk of surge voltage coupling in antenna cables is not completely eliminated. Surge voltages can even reach the sensitive interfaces of transceiver systems via this cable path.

The high frequencies of wireless transmission require the use of protective devices with low self-capacitance or low insertion loss with good impedance matching. Nevertheless, a good level of protection is required with high discharge capacity. For this reason, most protective devices are equipped with powerful gas-filled surge protective devices or with the Lambda/4 technology.

LAMBDA/4 technology

The Lambda/4 technology uses a short circuit between the inner conductor and the shield. The length of the cable between the short circuit and the inner conductor matches the frequency that is allowed to pass through without attenuation. A great advantage in this technology is achieving a very good (low) voltage protection level, as the protective device functions as a short circuit in the frequency range of surge voltages. However, it must be taken into account that the cable that is connected to the Lambda/4 protective device cannot use a DC power supply. Relatively wide bandwidth signals (e.g. 0.8 – 2.25 GHz) can be transmitted by means of RF-optimized Lambda/4 protective devices. Fig. 103 shows a typical design of a protective device with Lambda/4 technology.

The most common applications for SPDs in telecommunications are:

Antenna connection of television and radio receivers

The protective devices for radio and television devices are generally mounted between the antenna wall connection and the outgoing antenna cable. For satellite receivers, there are multi-channel protective devices for wall mounting. Broadband cable and antenna connections generally have

TV and RF connectors in accordance with DIN 45325. Satellite receivers are connected via F connectors.

Video communication

The applications in video communication extend from monitoring buildings, public areas, and institutes right through to sport and leisure facilities. The continuous availability of this monitoring equipment requires suitable surge protective devices. As a general rule, coaxial attachment plugs are used as protective devices, with BNC or TNC connectors.

Radio link and mobile phone systems

Radio link technology enables wireless transmission of data. The radio waves produced are transmitted in multiplex mode using panel antennas with a carrier frequency of between 1 and 40 GHz. Common types of antennas are parabolic reflectors, shell antennas, and horn antennas. The nominal frequencies of useful signals in this range are between 0.8 GHz and 2.7 GHz. N, SMA or 7/16 connectors are used as the connection technology for the protective devices.

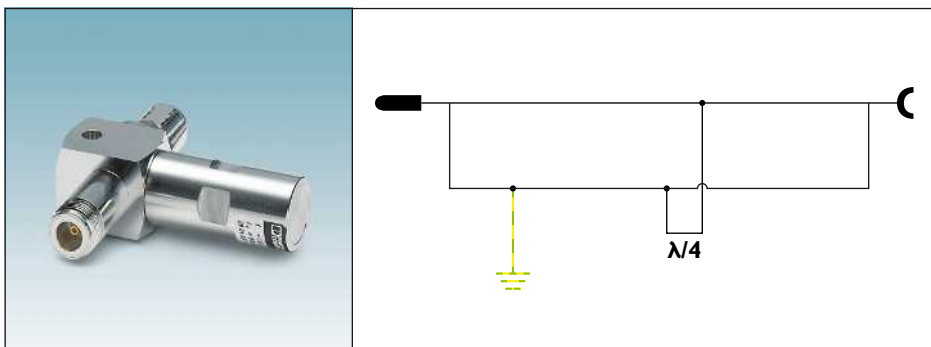

Fig. 103: CN-LAMBDA/4 - protective device with Lambda/4 technology

CN-LAMBDA/4

Using the CN-LAMBDA/4-2.25 protective device, the widest range of transmission systems can be actively protected in the GHz range. This is achieved by means of a broadband LAMBDA/4 technology.

7 Glossary

ATEX

ATEX is a widely used synonym for the ATEX directive issued by the European Union. The ATEX designation is derived from the French abbreviation for "atmosphères explosibles".

Binary signals

By binary signals, we mean digital signals that only take on the state of "high" or "low". Generally, these signals relate to a common reference potential or a shared return conductor.

Dielectric strength

Insulation strength of the electrical circuits of a piece of equipment when compared to withstand and surge voltages with amplitudes above the maximum continuous voltage.

EMC

EMC stands for electromagnetic compatibility, the capacity of an apparatus, plant or system to work satisfactorily in an electromagnetic environment, without causing electromagnetic interference itself that would be unacceptable for the apparatus, plants or system in this setting.

Follow current interrupt rating (I_{fi})

The follow current interrupt rating indicates the prospective r.m.s. value of the short-circuit current at the installation location of a voltage-switching SPD, up to which the SPD once again transitions into a high ohmic state if the maximum U_c continuous voltage is being independently applied due to a surge current, without triggering an upstream overcurrent protective device.

Gas discharge tube, GDT

Gas-filled surge protective device

Insertion loss

The attenuation value is defined as the ratio of voltages that occur immediately before and after the insertion point of the protective device to be tested. The result is expressed in decibels.

Lightning protection class

A standardized classification of lightning protection systems into classes I to IV. They are based on a set of lightning current parameter values with regard to probability, whereby the largest and smallest measured values in the event of naturally occurring strikes cannot be exceeded and the strikes can be safely discharged. Lightning protection class I thereby corresponds to the highest measured values and the greatest probability of capturing a strike. The values decrease accordingly, down to lightning protection class IV.

Lightning protection system

System consisting of external interception rods, protective devices, and grounding system, as well as equipotential bonding system and coordinated SPD system within the physical structure to protect against damage caused by surge voltages and surge currents from lightning strikes.

Lightning protection zone (LPZ)

A zone in which the electromagnetic environment is determined with regard to risk of lightning. All (supply) lines that cross zone limits must be included in the lightning protection equipotential bonding by means of corresponding SPDs. The zone limits of a lightning zone

are not necessarily physical limits (e.g., walls, floor or ceiling).

Maximum continuous voltage (U_c)

Maximum r.m.s. value of the voltage that can continuously be applied to the mode of protection of the SPDs. The maximum continuous voltage must be at least 10% higher than the value of the nominal voltage. In systems with greater voltage fluctuations, SPDs with a greater difference between U_c and U_N must be used.

Nominal discharge current (I_n)

Peak value of the current flowing through the SPD with pulse shape (8/20 μ s). The pulse shape (8/20 μ s) of a surge current is characteristic of the effects of an indirect lightning strike or switching operation. The value of the nominal discharge current is used for a variety of tests on an SPD, including those used to determine the voltage protection level. Depending on the lightning protection class assigned to a lightning protection system, the SPDs must have minimum values that correspond to this value.

Nominal load current (I_L)

Maximum r.m.s. value of the nominal current, which can flow to an ohmic load that is connected to the protected output of the SPD. This maximum value is specified by the parts carrying operational current within the SPDs; these must be able to withstand the continuous thermal current load.

Nominal voltage (U_N)

The nominal value of the voltage of the current or signal circuit based on the use envisaged for the SPDs. The nominal

voltage stated for an SPD corresponds to the system voltage of the typical SPD installation site for a standard three-phase system, e.g., 230/400 V AC. Lower system voltages can also be protected by the SPD. In the event of higher system voltages, it must be decided on a case-to-case basis as to whether the SPD can be used and if there are restrictions to observe.

Off-load voltage (U_{OC})

Off-load voltage of the hybrid generator at the terminal points of the SPD. A hybrid generator creates a combined surge, i.e. in off-load, it supplies a voltage pulse with a defined pulse shape, generally (1.2/50 μ s), and in a short circuit, a current pulse with a defined pulse shape, generally (8/20 μ s). The combined surge is characteristic of the effects of an induced surge voltage. Depending on the protection class assigned to a lightning protection system, the SPDs must have minimum values that correspond to this value.

Overcurrent protective device, OCPD

Overcurrent protective device

Overvoltage category

Division of equipment into categories I to IV depending on their surge voltage resistance. Overvoltage category I corresponds to the lowest value and consists of particularly sensitive (end) devices. These values increase accordingly, up to overvoltage category IV. The values for the individual categories also depend on the voltage level of the power supply system.

Power over Ethernet (PoE)

Power over Ethernet is a process in which the auxiliary energy for the connected devices is also transmitted via the Ethernet data cable.

Pulse discharge current (I_{imp})

Peak value of the current flowing through the SPD with pulse shape (10/350 μ s). The pulse shape (10/350 μ s) of a surge current is characteristic of the effects of a direct lightning strike. The value of the pulse discharge current is used for special SPD tests to demonstrate carrying capacity with regard to high-energy lightning currents. According to the lightning protection class assigned to a lightning protection system, the SPDs must have minimum values that correspond to this value.

Safe Energy Control technology, SEC technology

Technology for SPDs for protecting the power supply. SPDs with SEC technology are characterized by the following:

- Impact-free and durable
- Backup-fuse-free solution for every application
- Compact and consistent pluggable design

Short-circuit withstand capability (I_{SCCR})

Maximum prospective short-circuit current of the electrical network, for which the SPD is rated in conjunction with the upstream overcurrent protective device. The short-circuit withstand capability indicates the maximum prospective short-circuit current at which the SPD can be used at the installation location. The corresponding tests to determine this value are carried out in connection with the upstream overcurrent protective device. In the event that the special surge protective devices for PV systems correspond to the value I_{SCPV} , this is the maximum DC short-circuit current of a system up to which the SPD may be used.

Surge current

A pulse-shaped current that is characterized by a significant rise in current within a short period of time. Typical pulse shapes are (8/20 μ s), with which the voltage-limiting behavior of SPDs can be checked, and (10/350 μ s), with which the lightning current capacity of the SPDs can be tested.

Surge protective device, SPD

Surge protective device

Surge voltage

A pulse-shaped voltage that is characterized by a significant rise in voltage within a short period of time. A typical pulse shape is (1.2/50 μ s). The response behavior of SPDs or the surge voltage resistance of equipment can also be tested with this.

TVS

TVS stands for Transient Voltage Suppression.

Voltage protection level (U_p)

Maximum voltage that can occur on the connection terminal blocks of the SPD while loaded with a pulse of specific voltage steepness and a discharge surge current of specified amplitude and wave form. This value characterizes the surge voltage protective effect of the SPD. In the event of a surge voltage phenomenon within the performance parameters of the SPD, the voltage is safely limited to a maximum of this value at the protected connections of the SPD.

8

References

- [1] International Electrotechnical Commission. IEC 62305-1 - Lightning protection - Part 1: General principles. s.l. : VDE Verlag GmbH, 2010.
- [2] International Electrotechnical Commission. IEC 62305-2 - Lightning protection - Part 2: Risk management. s.l. : VDE Verlag GmbH, 2010.
- [3] International Electrotechnical Commission. IEC 62305-3 - Lightning protection - Part 3: Physical damage to structures and life hazard. s.l. : VDE Verlag GmbH, 2010.
- [4] International Electrotechnical Commission. IEC 62305-4 - Lightning protection - Part 4: Protection against lightning. Electrical and electronic systems within structures. s.l.: VDE Verlag GmbH, 2010.
- [5] International Electrotechnical Commission. IEC 60364-4-44 - Low-voltage electrical installations - Part 4-44: Protection for safety - Protection against voltage disturbances and electromagnetic disturbances. s.l. : VDE Verlag GmbH, 2015.
- [6] International Electrotechnical Commission. IEC 61643-11 - Surge protective devices connected to low-voltage power systems - Requirements and test methods. s.l. : VDE Verlag GmbH, 2011.
- [7] International Electrotechnical Commission. IEC 61643-21 - Surge protective devices connected to telecommunications and signaling networks - Performance requirements and testing methods. s.l. : VDE Verlag GmbH, 2000.
- [8] International Electrotechnical Commission. IEC 61643-31 - Low-voltage surge protective devices – Requirements and tests for surge protective devices to be used in photovoltaic installations. Requirements and test methods. s.l. : VDE Verlag GmbH, 2015.
- [9] International Electrotechnical Commission. IEC 60664-1 - Insulation coordination for equipment within low-voltage systems - Part 1: Principles, requirements, and tests. s.l. : VDE Verlag GmbH, 2007.
- [10] International Electrotechnical Commission. IEC 60364-1 - Low-voltage electrical installations - Part 1: Fundamental principles, assessment of general characteristics, definitions. s.l. : VDE Verlag GmbH, 2005.
- [11] International Electrotechnical Commission. IEC 60364-5-53 - Electrical installations of buildings - Part 5: Selection and erection of electrical equipment; Section 53: Switchgear and control. s.l. : VDE Verlag GmbH, 2015.
- [12] International Electrotechnical Commission. IEC 60364-4-43 - Low-voltage electrical installations - Part 4-43: Protection for safety - Protection against overcurrent. s.l. : VDE Verlag GmbH, 2008.
- [13] European Committee for Electrotechnical Standardization. CLC/TS 50539-12 - Low-voltage surge protective devices connected to photovoltaic installations - Selection and application principles. s.l. : VDE Verlag GmbH, 2013.
- [14] Phoenix Contact GmbH & Co. KG. TRABTECH surge protection - user manual for specialist electrical planners. 2015.
- [15] International Electrotechnical Commission. IEC 61643-12 - Surge protective devices connected to low-voltage power systems - Selection and application principles. s.l. : VDE Verlag GmbH, 2010.
- [16] International Electrotechnical Commission. IEC 61643-22 - Low-voltage surge protective devices - Surge protective devices connected to telecommunications and signaling - Selection and application principles. s.l. : VDE Verlag GmbH, 2007.
- [17] International Electrotechnical Commission. IEC 60079-11 (VDE 0170-7) - Explosive atmospheres - Part 11: Equipment protection by intrinsic safety "i" VDE-VERLAG GMBH, 2012
- [18] International Electrotechnical Commission. IEC 61643-32 - Low-voltage surge protective devices – Requirements and tests for surge protective devices to be used in photovoltaic installations - Selection and application. s.l.: VDE Verlag GmbH, 2015.

Open communication with customers and partners worldwide

Phoenix Contact is a global market leader based in Germany. We are known for producing forward-thinking products and solutions for the comprehensive electrification, networking, and automation of all sectors of the economy and infrastructure. With a global network, we maintain close relationships with our customers, something we believe is essential for our common success.

You can find your local partner at
phoenixcontact.com

