



POWER-TO-X

Working together to create a carbon-neutral future
with green hydrogen

Shaping a carbon-neutral future together

Power-to-X is the enabler for supplying power and, in turn, for coupling sectors that do not have any purely electrical solutions available today or in the foreseeable future. Maximum safety is key, with charging connector locking and precise temperature monitoring. The answer to decarbonization efforts in these sectors is to use hydrogen from renewable energy sources.

Our action fields

- Power-to-X
- Our solution portfolio
- Stationary fuel cells
- Fuel cells in marine and offshore applications
- Hydrogen services stations
- Electrolysis plants
- Pipelines

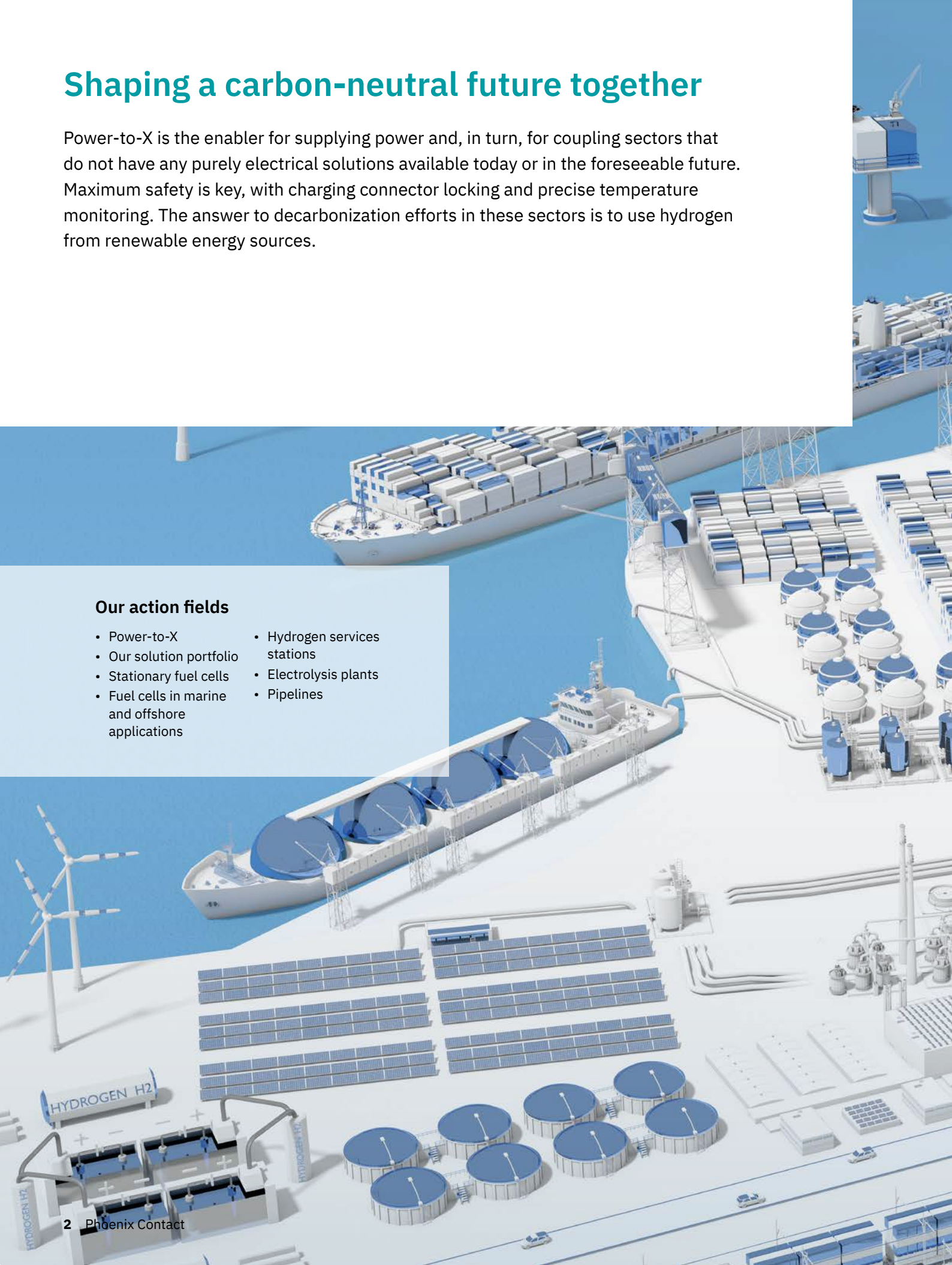

Service and compliance

- Project coordination
- Cybersecurity
- Functional safety
- Explosion protection
- Ready-to-use control cabinets with UL marking

Smart operations

- Data transparency
- Predictive maintenance
- System optimization
- Remote access
- Remote maintenance
- Redundancy concepts

Power-to-X to the All Electric Society

Solutions overview



AUTOMATION



Electrolysis
and fuel



Consulting and
Engineering and
Functional s



CONNECTORS



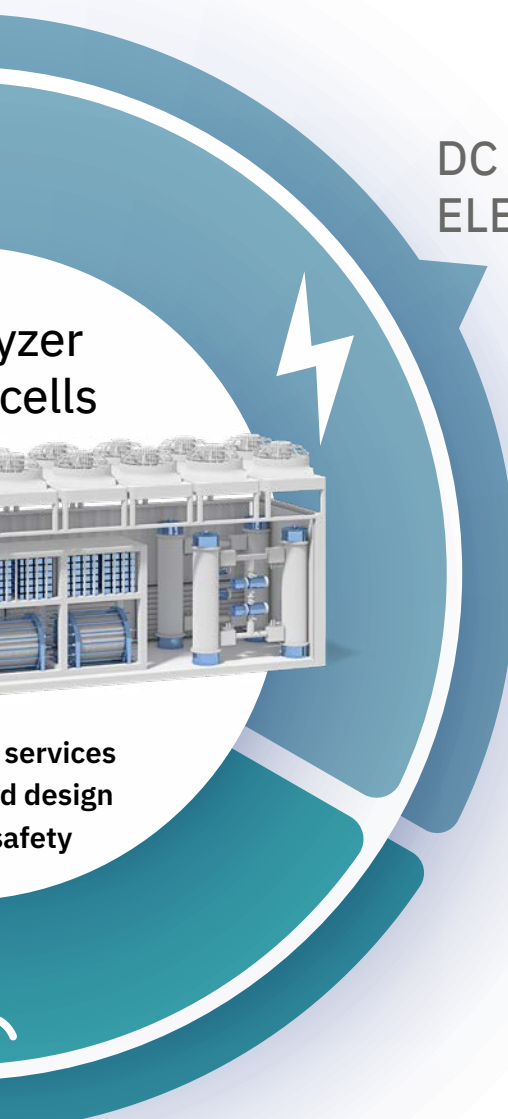

DC POWER ELECTRONICS



Our competence for a carbon-neutral future

- ✓ Solutions and products for automation, electrification and digitization from a single source
- ✓ Services for industrial security, UL marking, functional safety, and process reliability
- ✓ Decades of experience in the traditional process industry

Control solutions and safety technology

Fuel cells

The core function of a fuel cell is the production of electricity from a hydrogen-rich fuel (depending on the actual fuel cell technology, either direct hydrogen or natural gas, methanol, and others). The byproducts of this process are water and heat. In transportation applications like those with cars and trucks, this heat is typically dissipated by a cooling system. In stationary applications, the heat is sometimes recovered for cogeneration purposes (CHP) or as process heat.



Stationary applications:

- CHP applications (commercial buildings)
- Emergency power
- Off-grid electrical power

Transportation:

- Forklifts, trucks, trains, cars
- Maritime applications

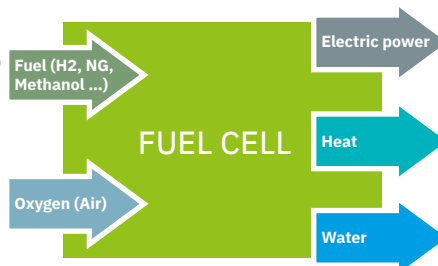

Fuel cell applications

Stationary fuel cells

- Holistic concepts for electrification, networking, and automation
- Compliant systems with certified solutions, e.g., for functional safety, explosion protection, and cybersecurity
- Open automation system for connection to external systems, remote maintenance, and cloud-based services, as well as easy integration into end-customer solutions

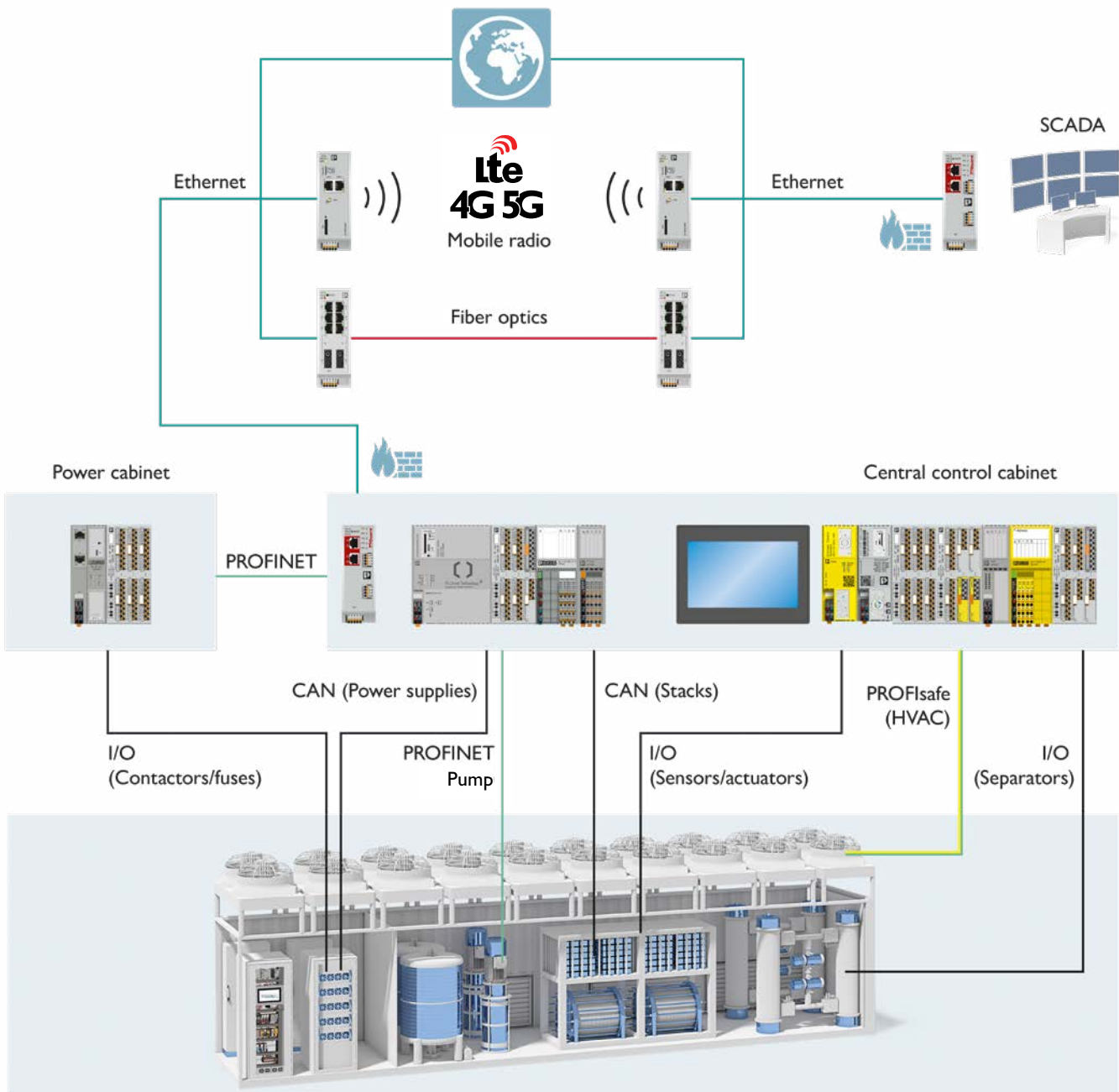

Fuel cell applications

Fuel cells in marine and offshore applications

- Maritime approvals
- Industry-compliant systems with certified solutions, e.g., for functional safety, explosion protection, and cybersecurity
- Holistic concepts for electrification, networking, and automation of fuel cell applications

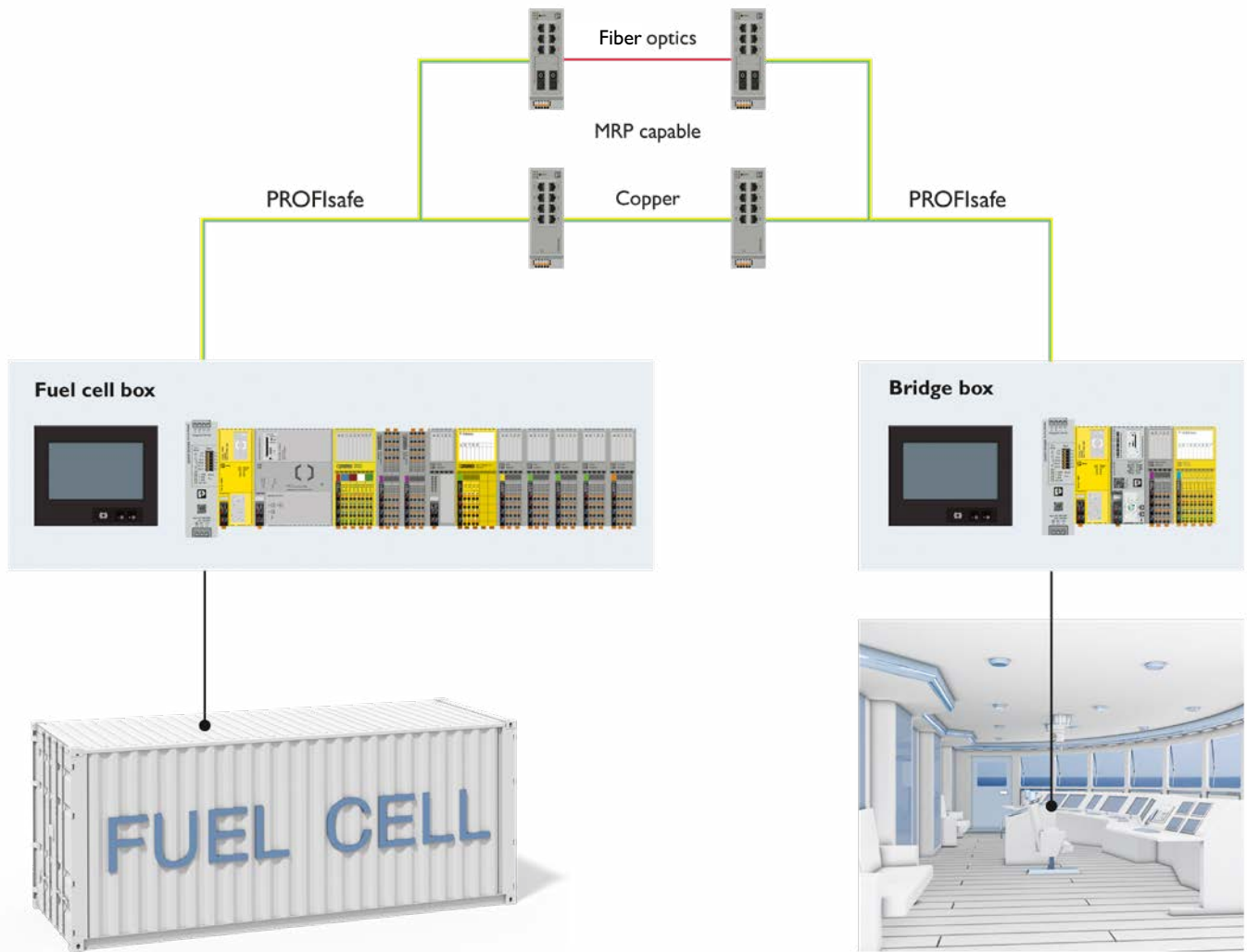

Schematic overview of a fuel cell system

The core of any fuel cell (regardless of the actual technology) is the fuel cell stacks/modules. Each stack consists of a series of individual cells, and several stacks are combined to achieve a specific electrical output power for the complete system. This combination of stacks requires the solution's connection to power, as well as data signals.

To ensure proper and efficient operation of the fuel cell, the operation temperature of the stacks needs to be controlled. For optimum operation, it is often necessary to keep the temperature of the air/oxygen in a specific range and to pressurize the oxidant with an auxiliary compressor.

The safety of the complete fuel cell system needs to be maintained at all times. H₂ is a highly explosive gas, and elevated levels of oxygen, especially in closed areas, can also be dangerous. This means measures have to be taken to avoid dangerous concentrations (e.g., maintain a forced ventilation or an overpressure condition in a critical part of the application) to detect dangerous situations (potential leaks, sudden pressure drops, critical gas concentrations, etc.) and to mitigate the effects of a critical situation, such as an emergency shut down, or to initiate purging or ventilation of critical areas. All this involves a thorough analysis of the possible hazards

and the creation of an appropriate safety concept (including functional safety and explosion protection). Depending on the application and regulatory requirements, the safety system may be integrated into the automatic control system or involve a separate safety controller.

The volume and intricacies of all the involved monitoring and control functions requires an automatic control system.

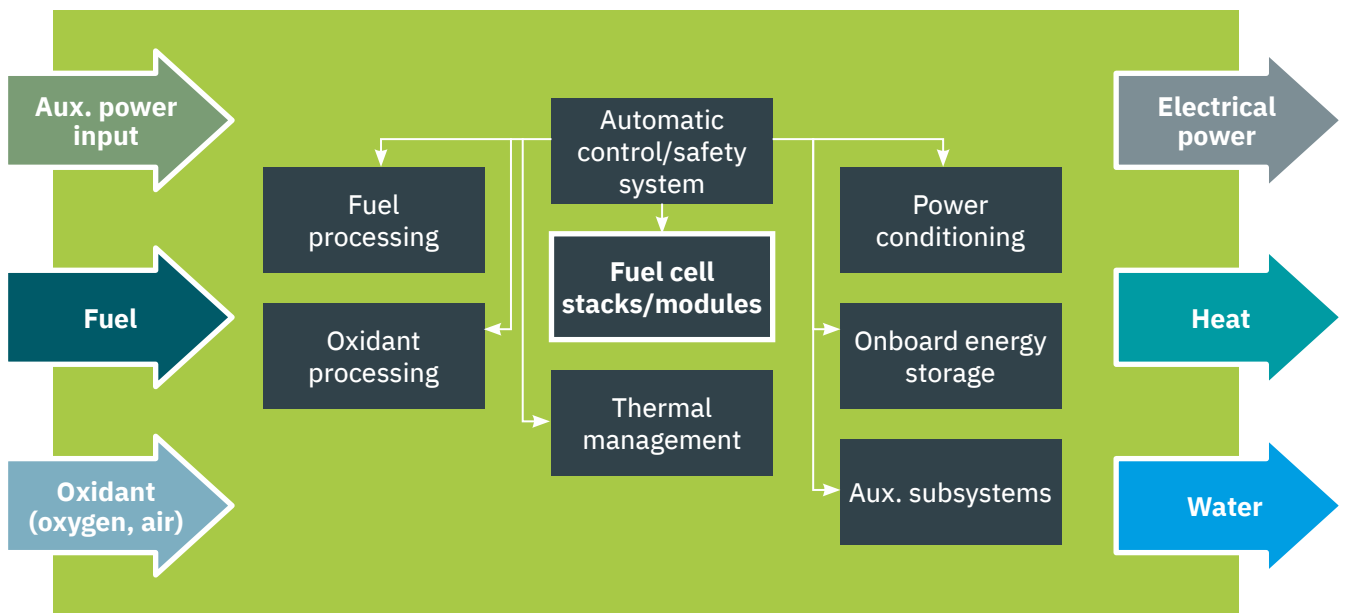

Core principle of electrolyzer applications

The core principle of hydrogen production by water electrolysis consists of splitting water in an electrochemical cell. This requires the provision of electrical power at an appropriate level. For the production of green hydrogen, the required electrical power needs to be produced by renewable means like solar, wind, or hydro power.

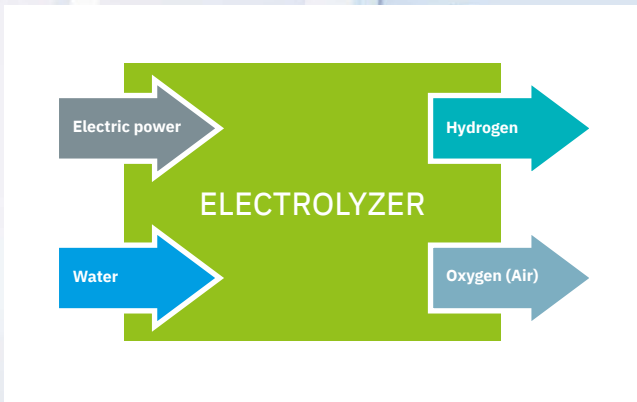
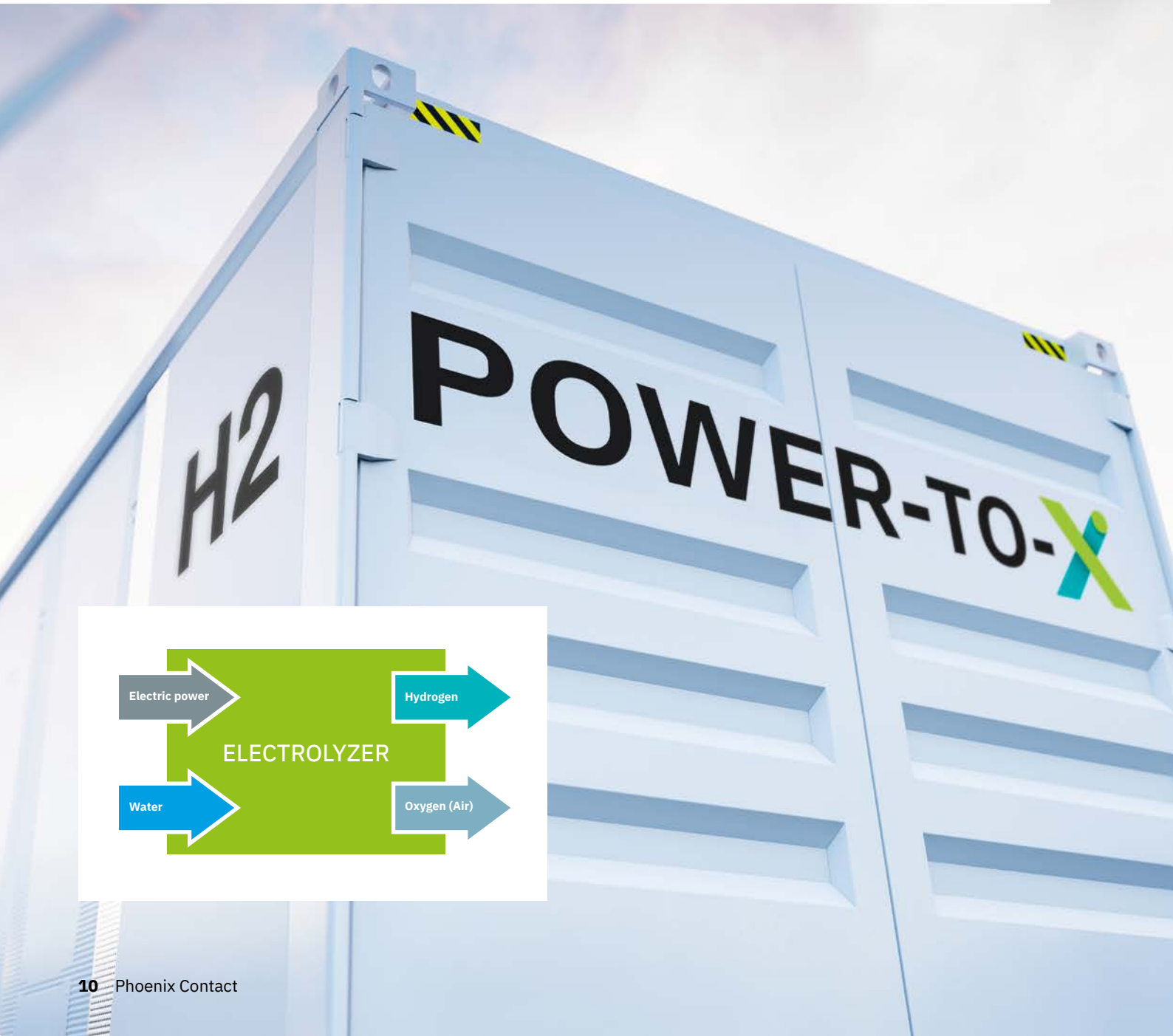

Ready-to-use control cabinets with UL marking

Efficient implementation of UL conformity procedure

Challenges

- Control cabinet design conforming to directives
- Selection of relevant directives, e.g., EMC, Low Voltage, RoHS, Recycling, etc.

Solutions

- Planning and manufacture of UL-compliant control cabinets in accordance with EN 60204-1/61439
- Guaranteed legal conformity through adherence to the latest legal requirements
- Services and training across the scope of UL compliance

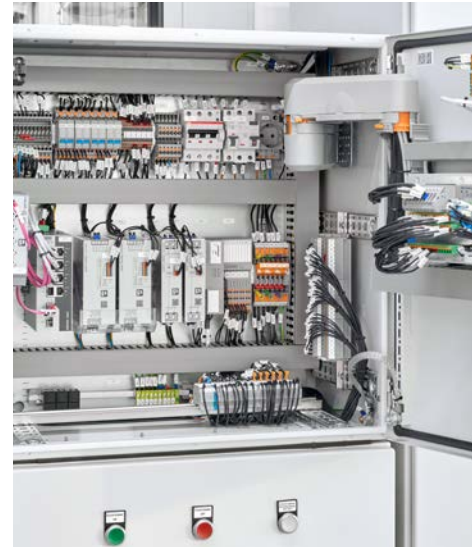

Electrolyzer applications

Power conditioning

CHARX AC/DC for grid-connected electrolyzer systems

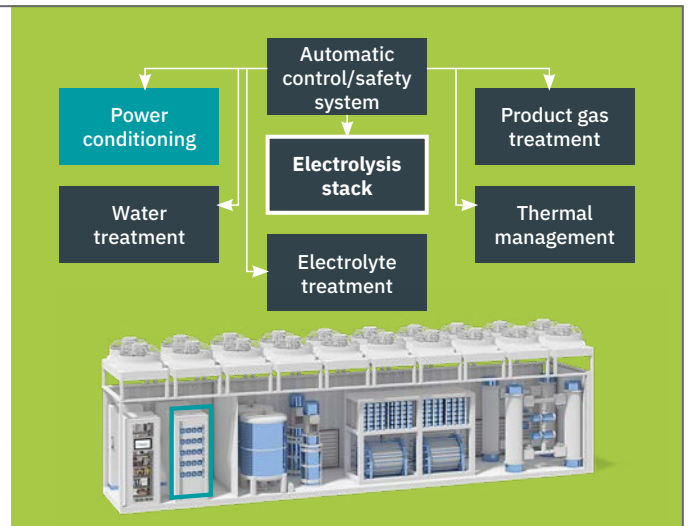
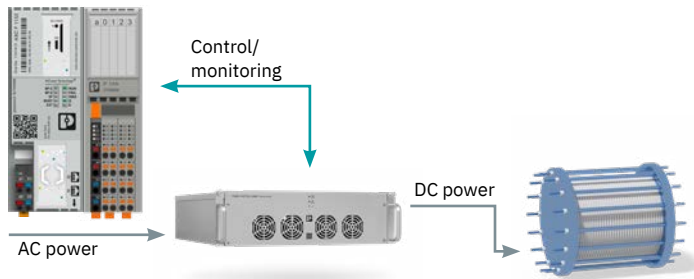

Automatic control

- PLCnext Control can provide the central automatic control for electrolyzer applications. With a wide portfolio of I/O extensions, communication interfaces, and functional extensions, practically all relevant subsystems can be monitored and controlled.
- Depending on the application and requirements from applicable codes and standards, relevant safety functions like gas monitoring, safe temperature measurement, or emergency shutdown can be combined with standard control by using safety extension modules. Alternatively, an independent separate safety control unit can be used.

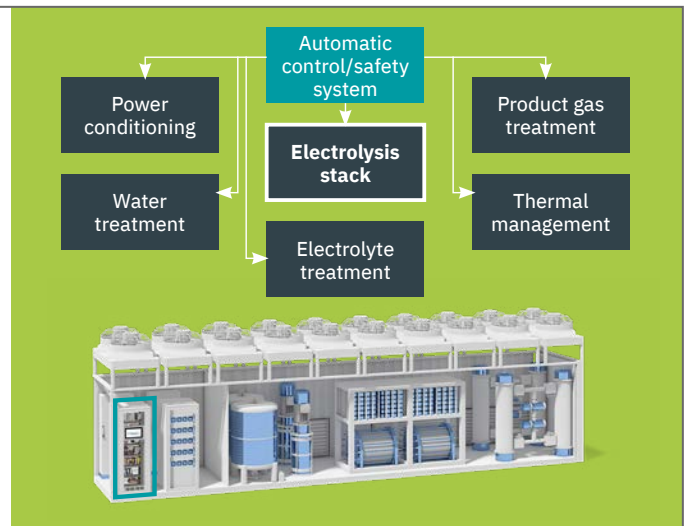

Electrolysis plants

Control solutions and DC power electronics

- Holistic concepts for electrification, networking, and automation
- Compliant systems with certified solutions including functional safety, explosion protection, and cybersecurity
- Open control system for connection to external systems, remote maintenance, and cloud-based services, as well as easy integration into large systems

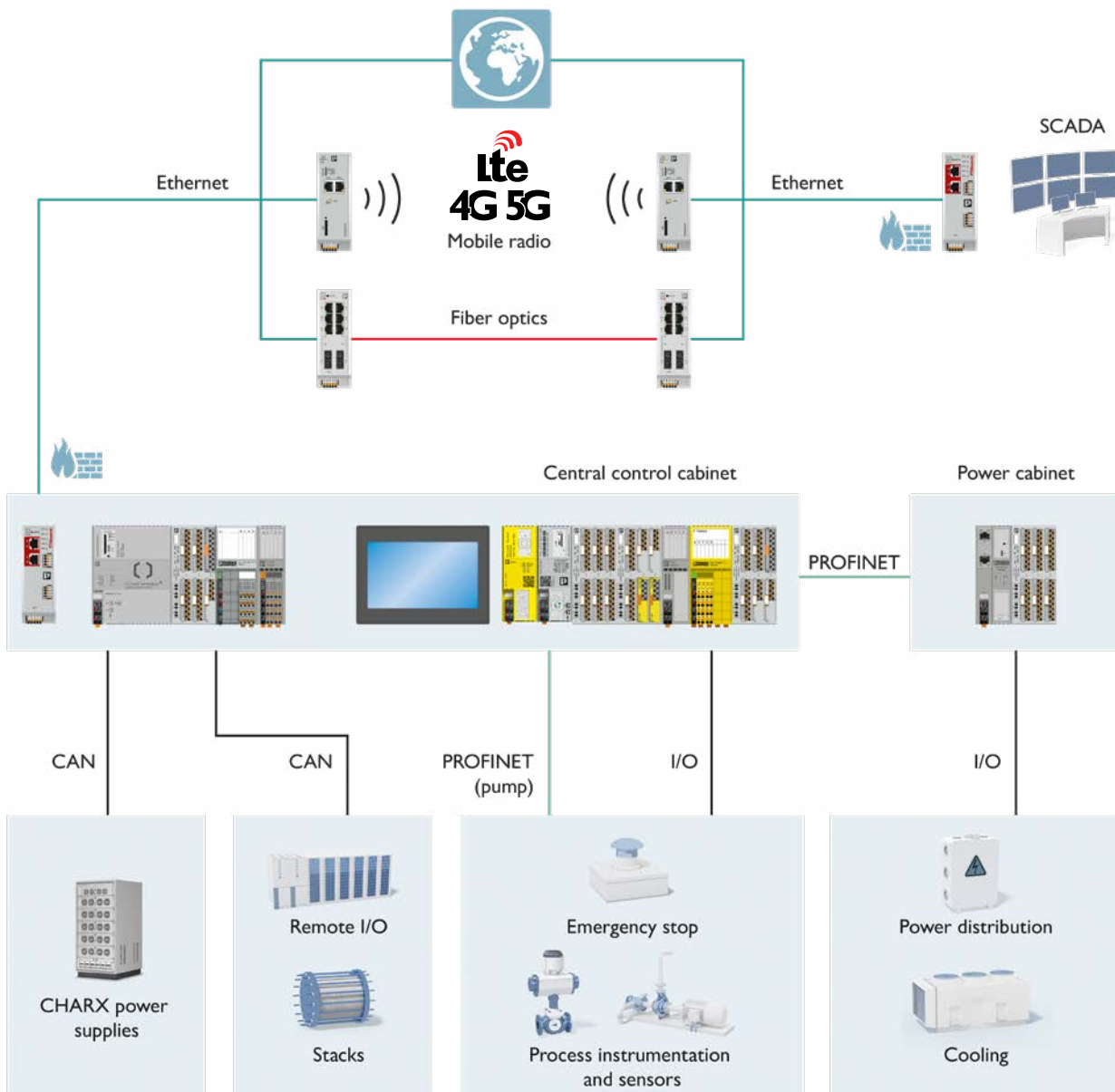
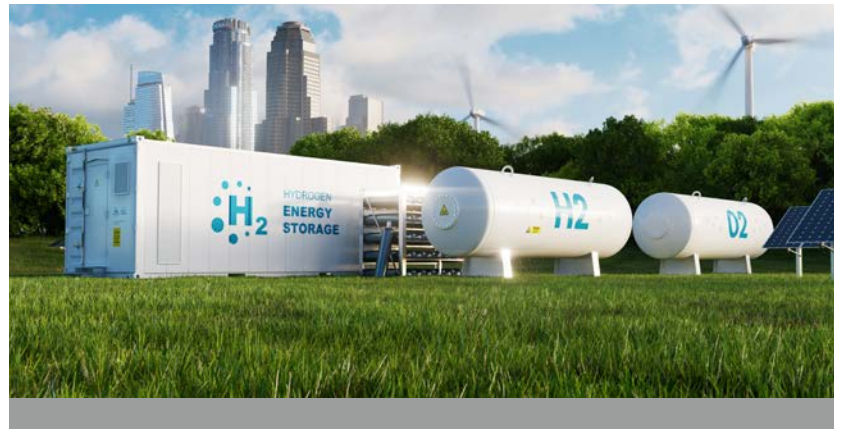

Software applications

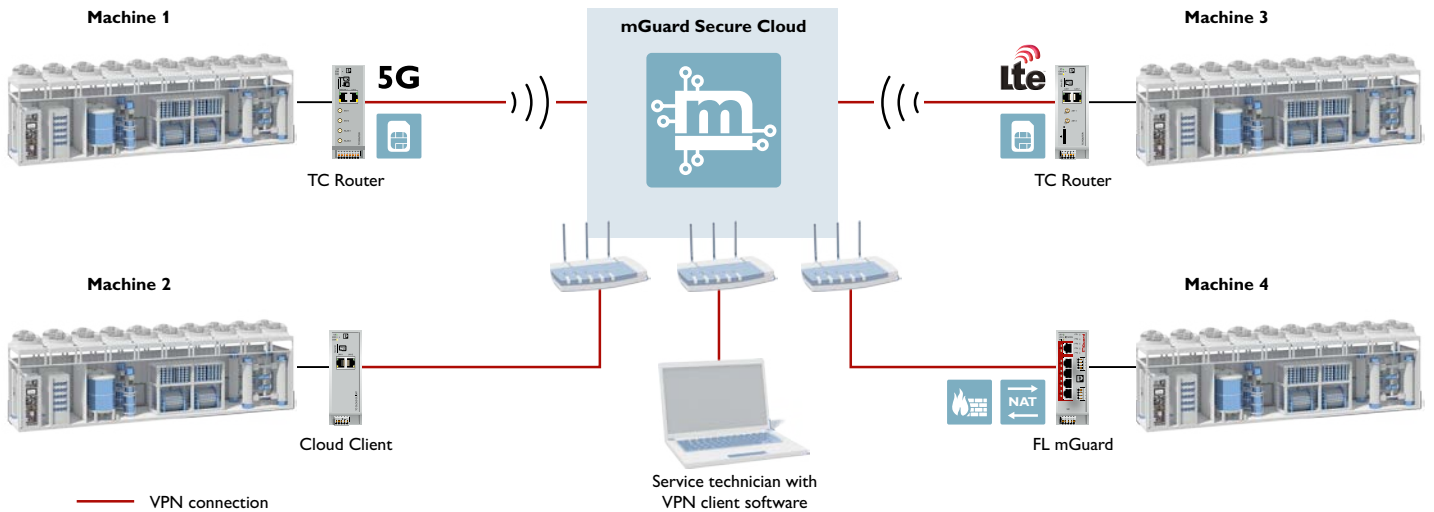
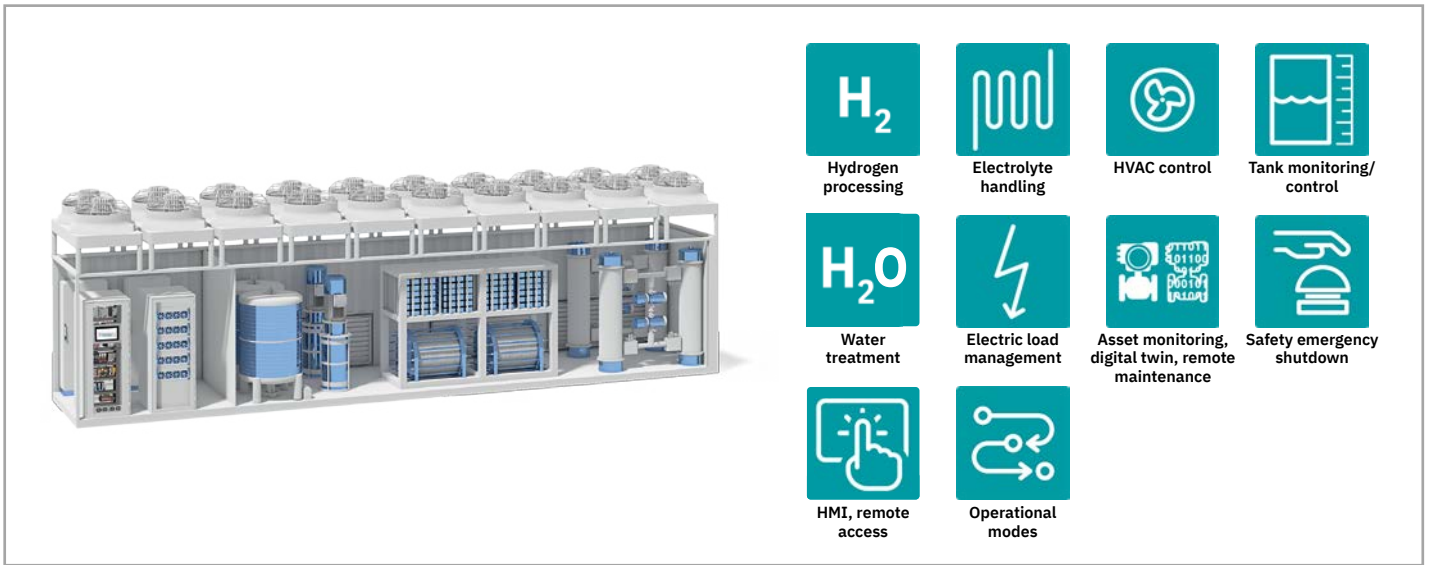

- ✔ Solutions and products for automation, electrification, and digitization from a single source
- ✔ Services for industrial security, UL marking, functional safety, and process reliability
- ✔ Many years of experience in the traditional process industry

Control cabinet planning with COMPLETE line

Control

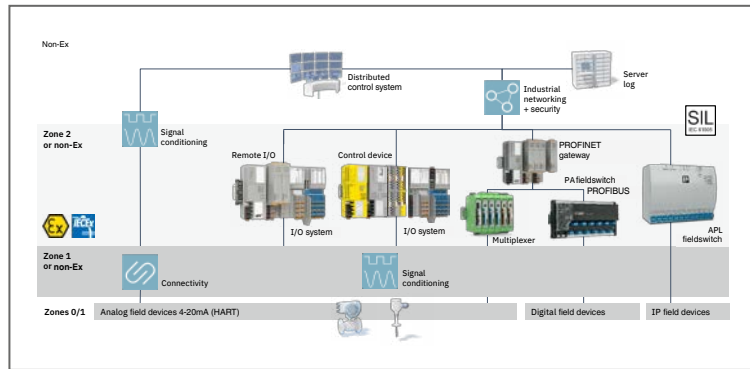

Power reliability

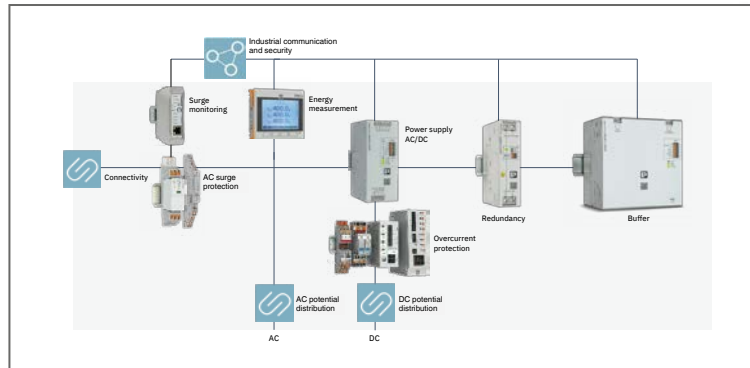

Connectivity

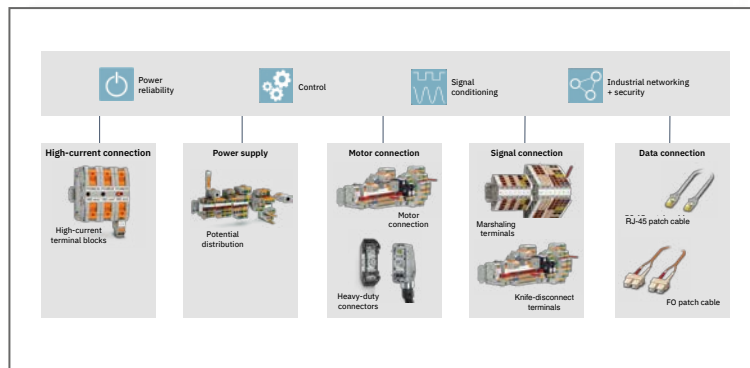

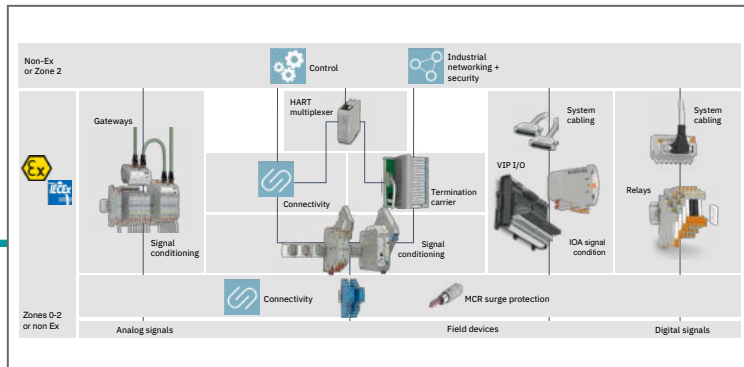

Signal conditioning

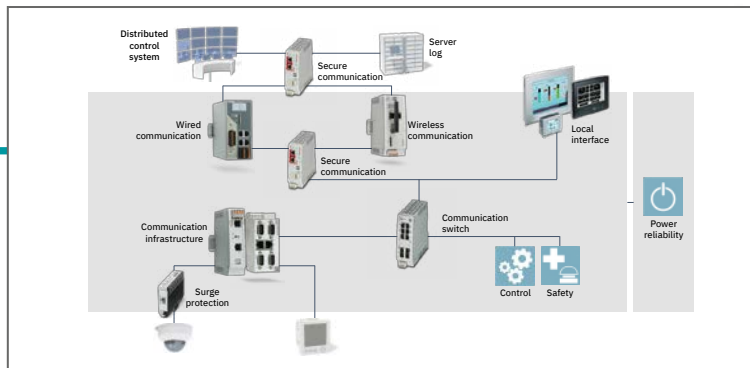

Industrial communication and security

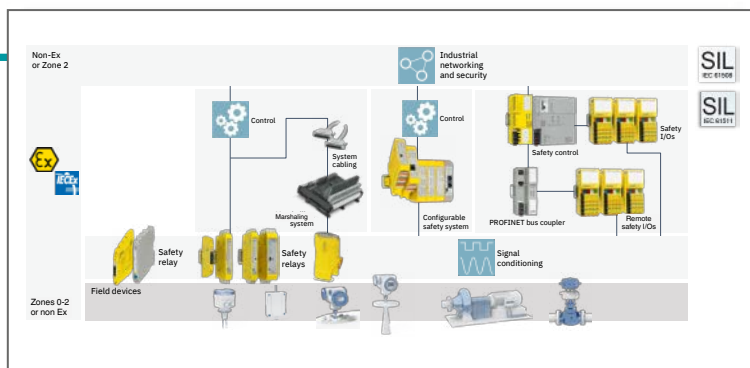

Safety

SIL
IEC 61508

Control cabinet planning with COMPLETE line

Control

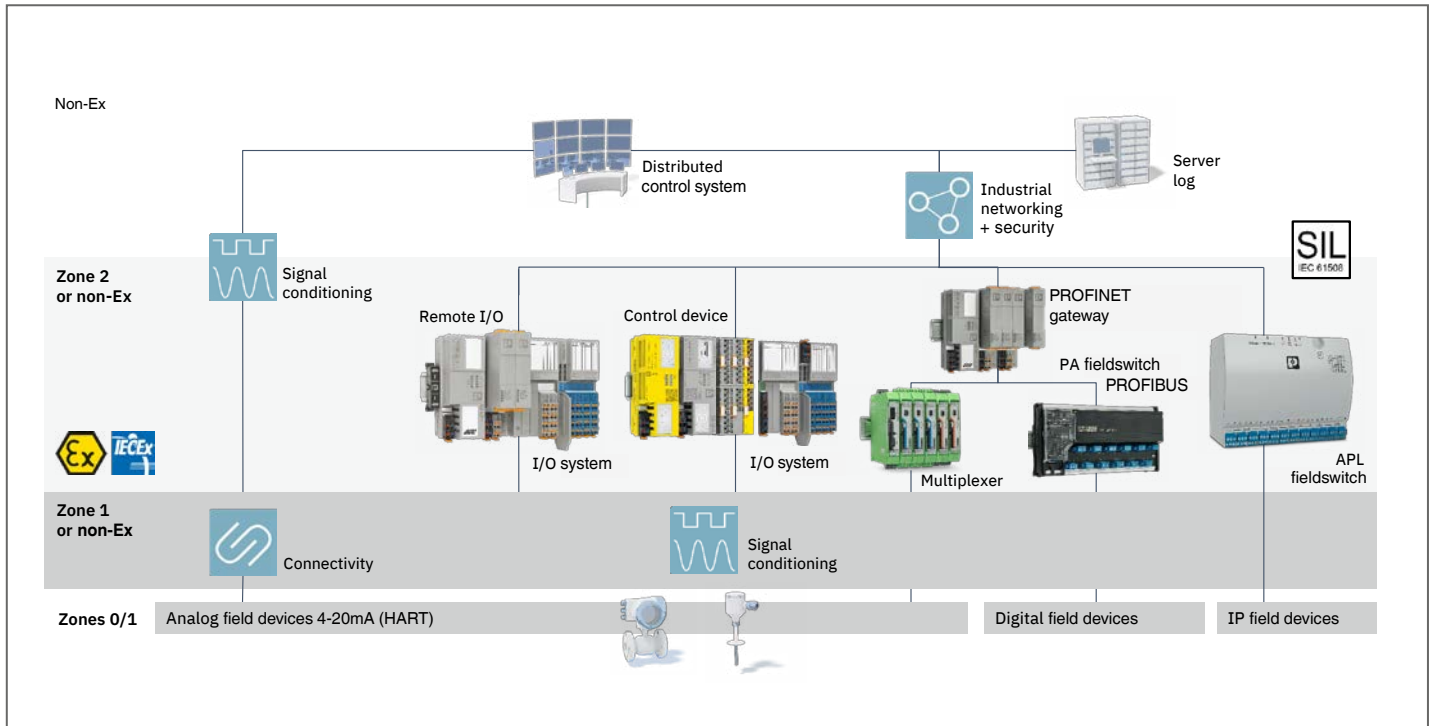

Power reliability

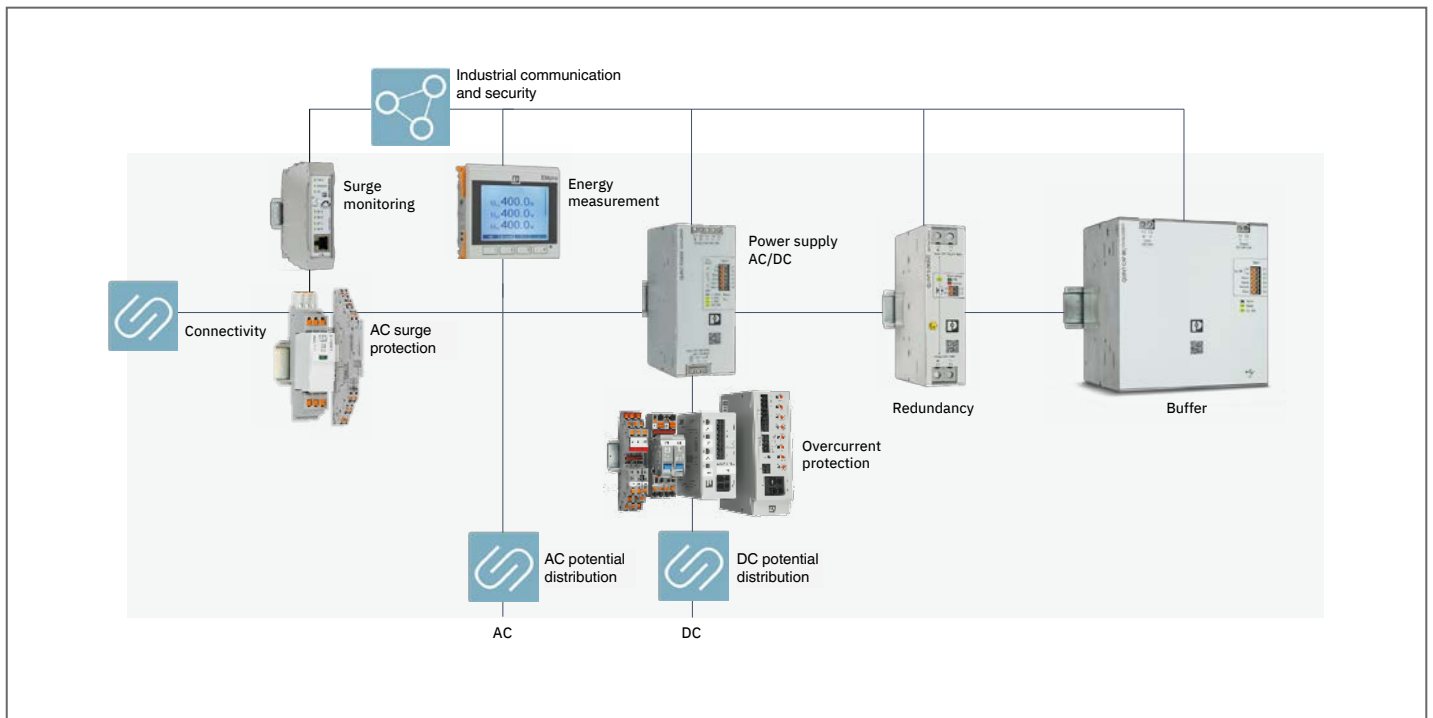

Connectivity

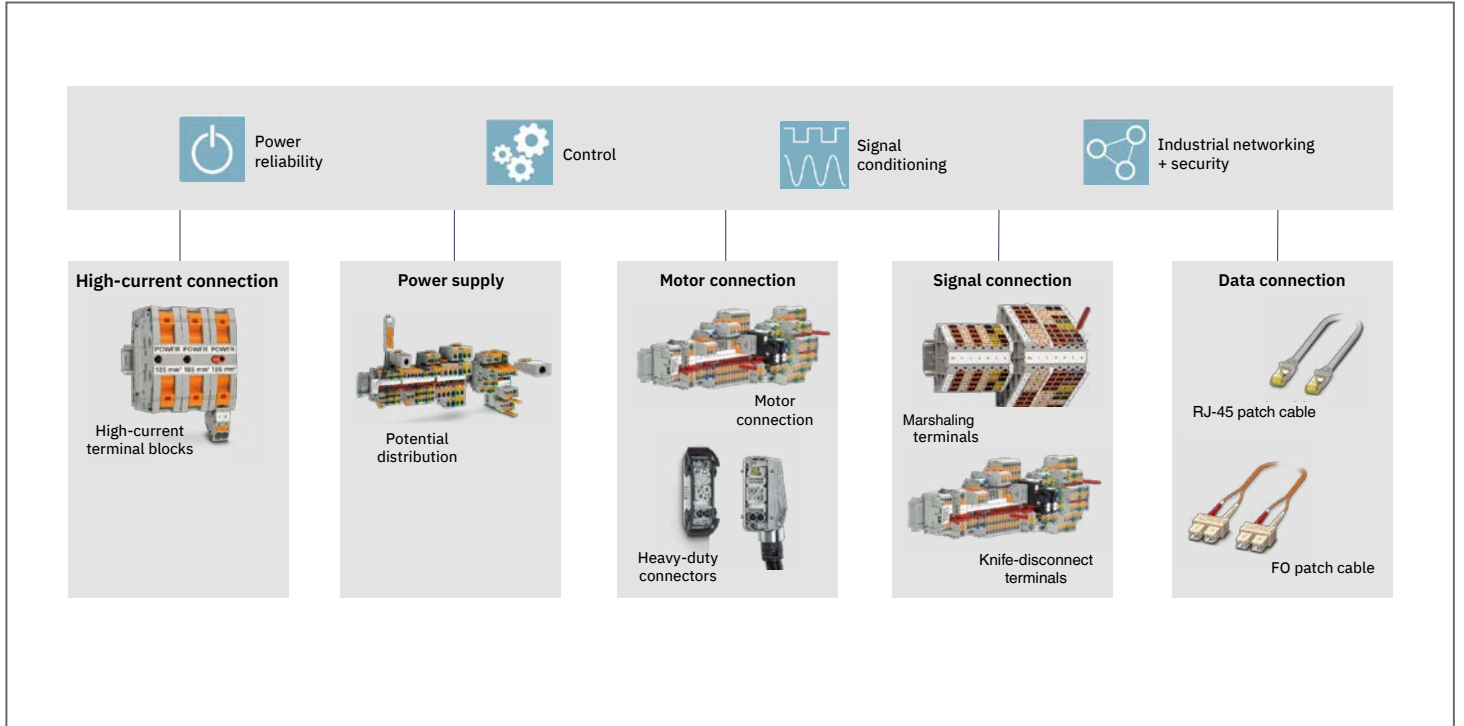

Connectivity solutions for electrolyzers

Connectors for electrolyzer stacks

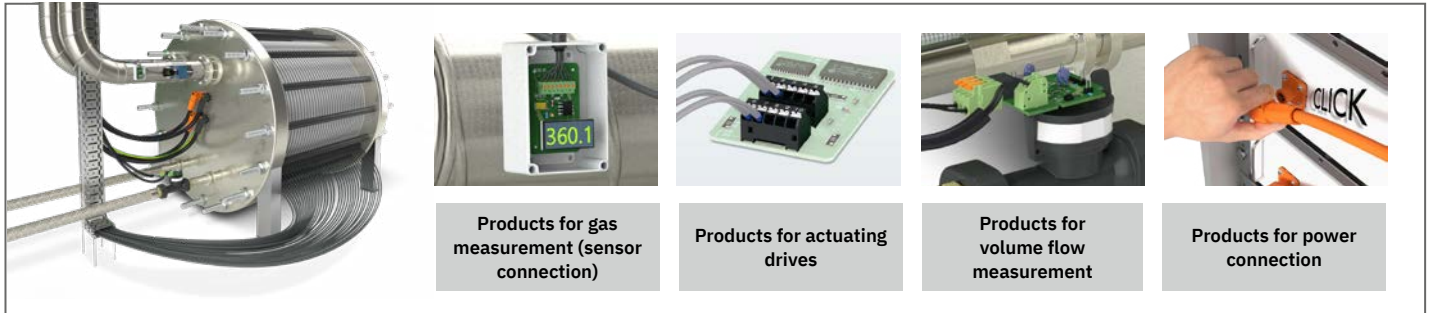

Voltage measurement at the electrolyzer stack

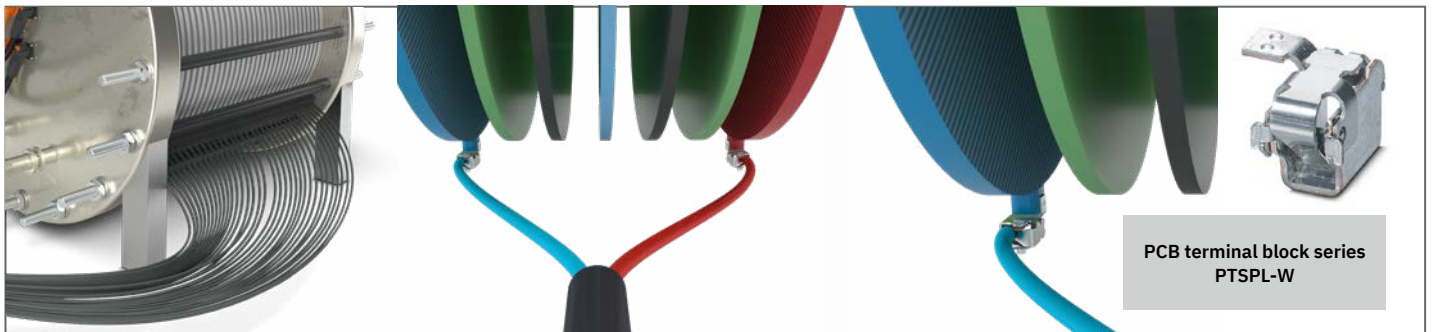

Control cabinet planning with COMPLETE line

Signal conditioning

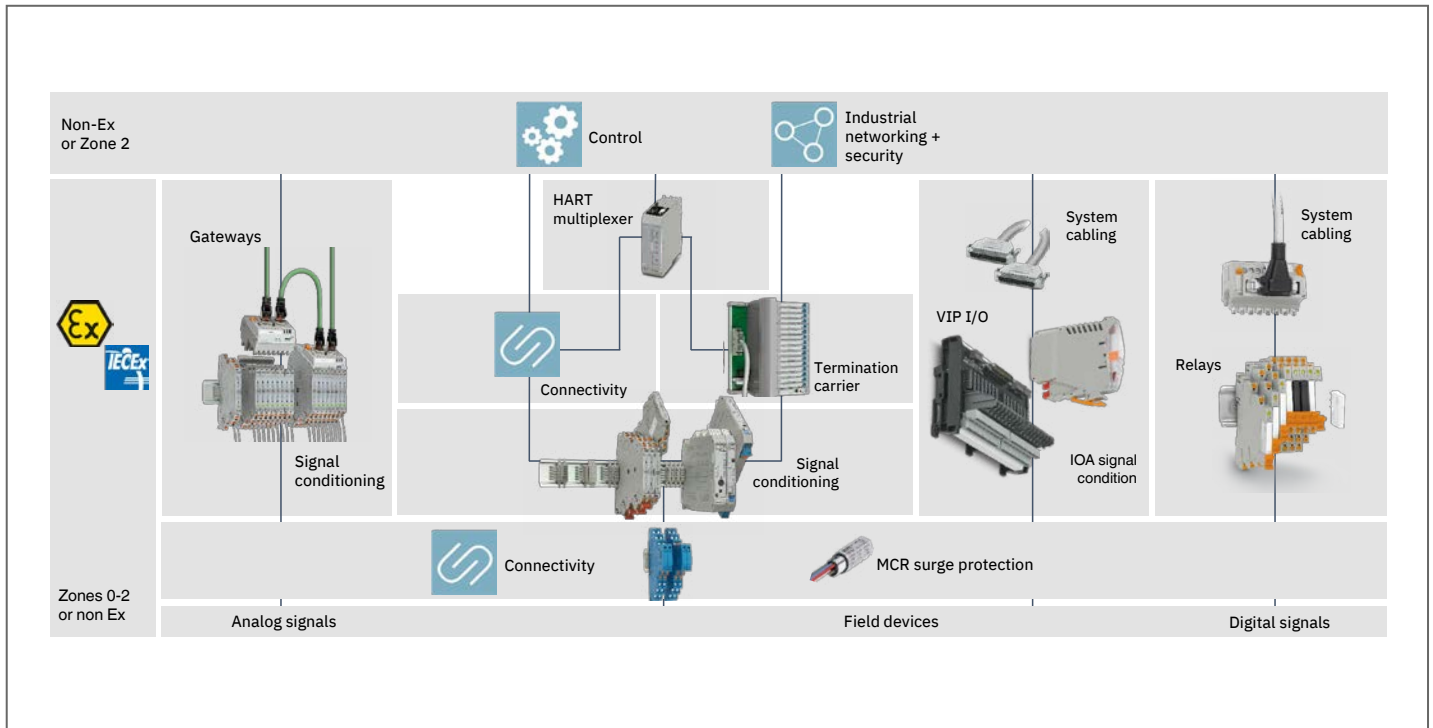

Industrial networking and security

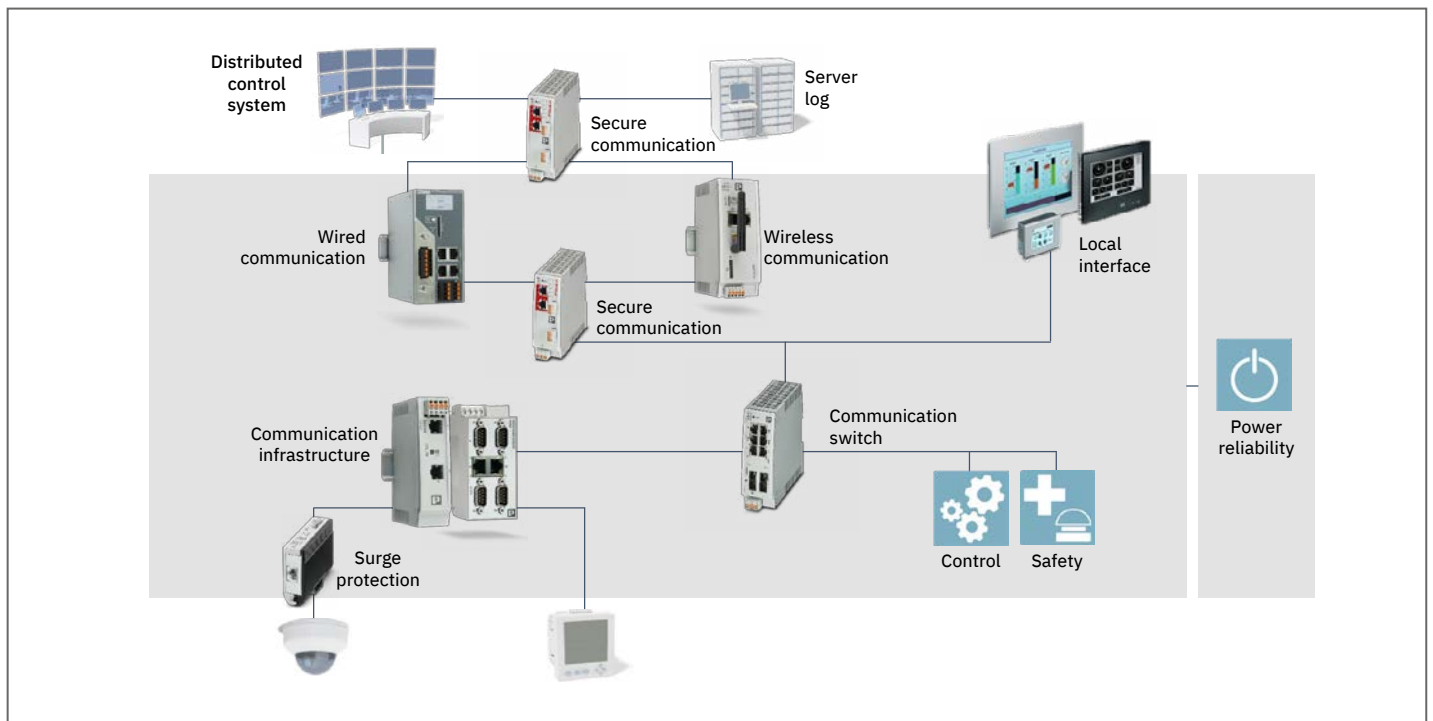

Functional safety

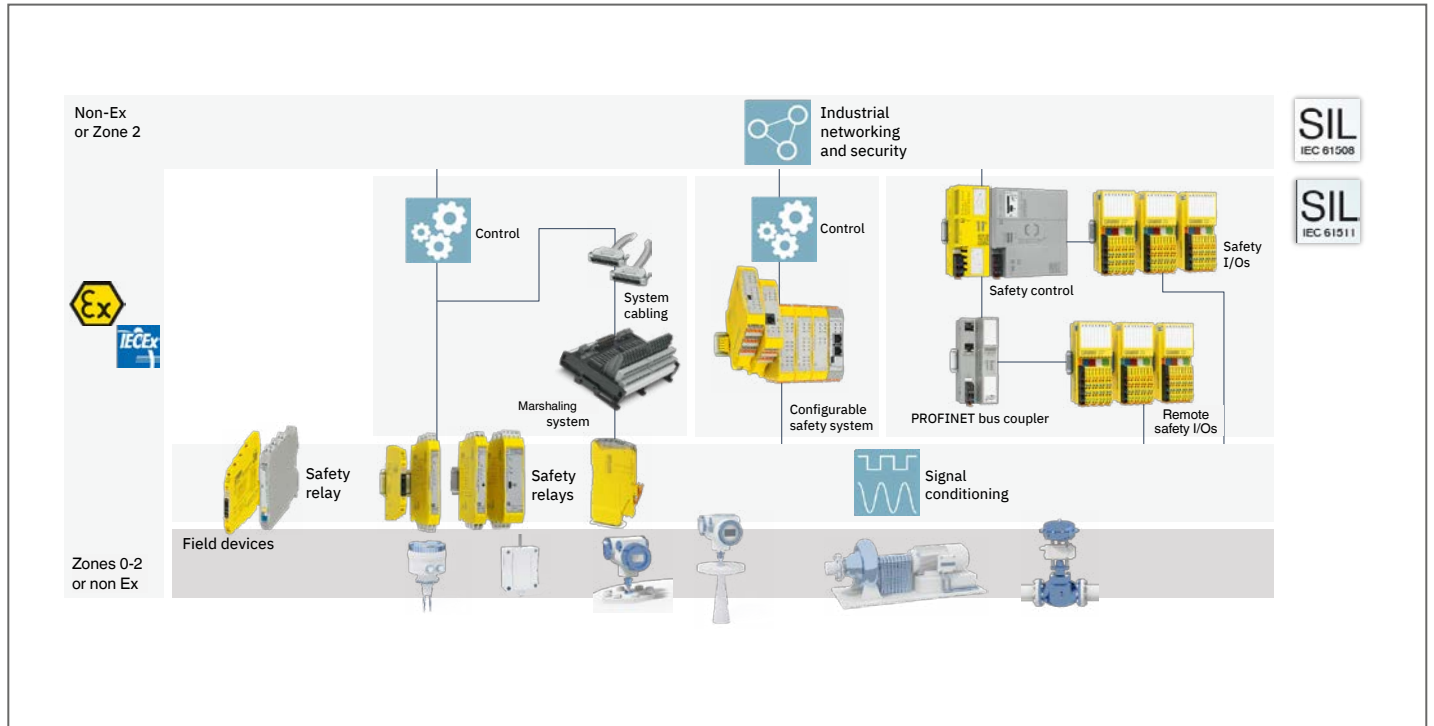

Power conversion

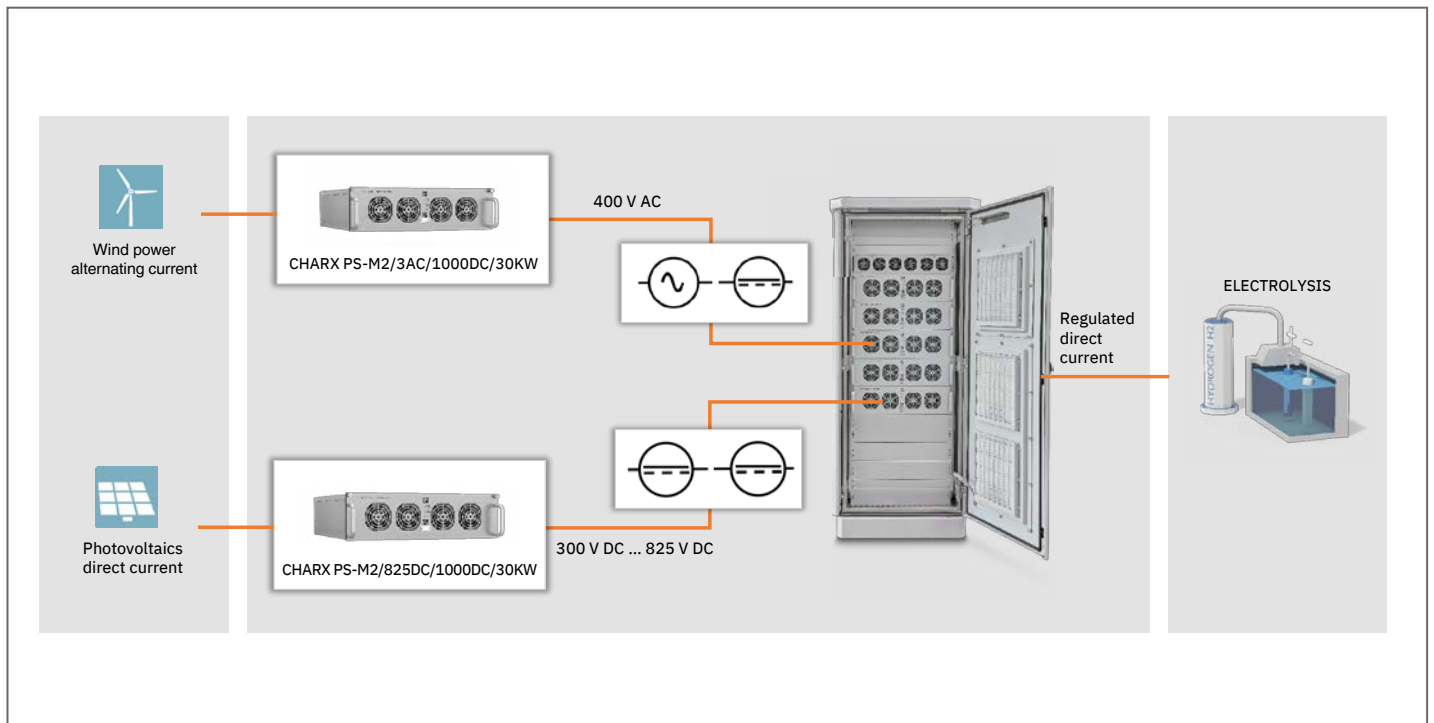

Pipelines

Time-synchronous data acquisition and transmission for pipeline monitoring

- Time synchronization via the NTP server service of the mGuard security router
- Different transmission media for flexible data transmission adapted to your system situation
- Connection of remote system parts, thanks to secure transmission via the Internet

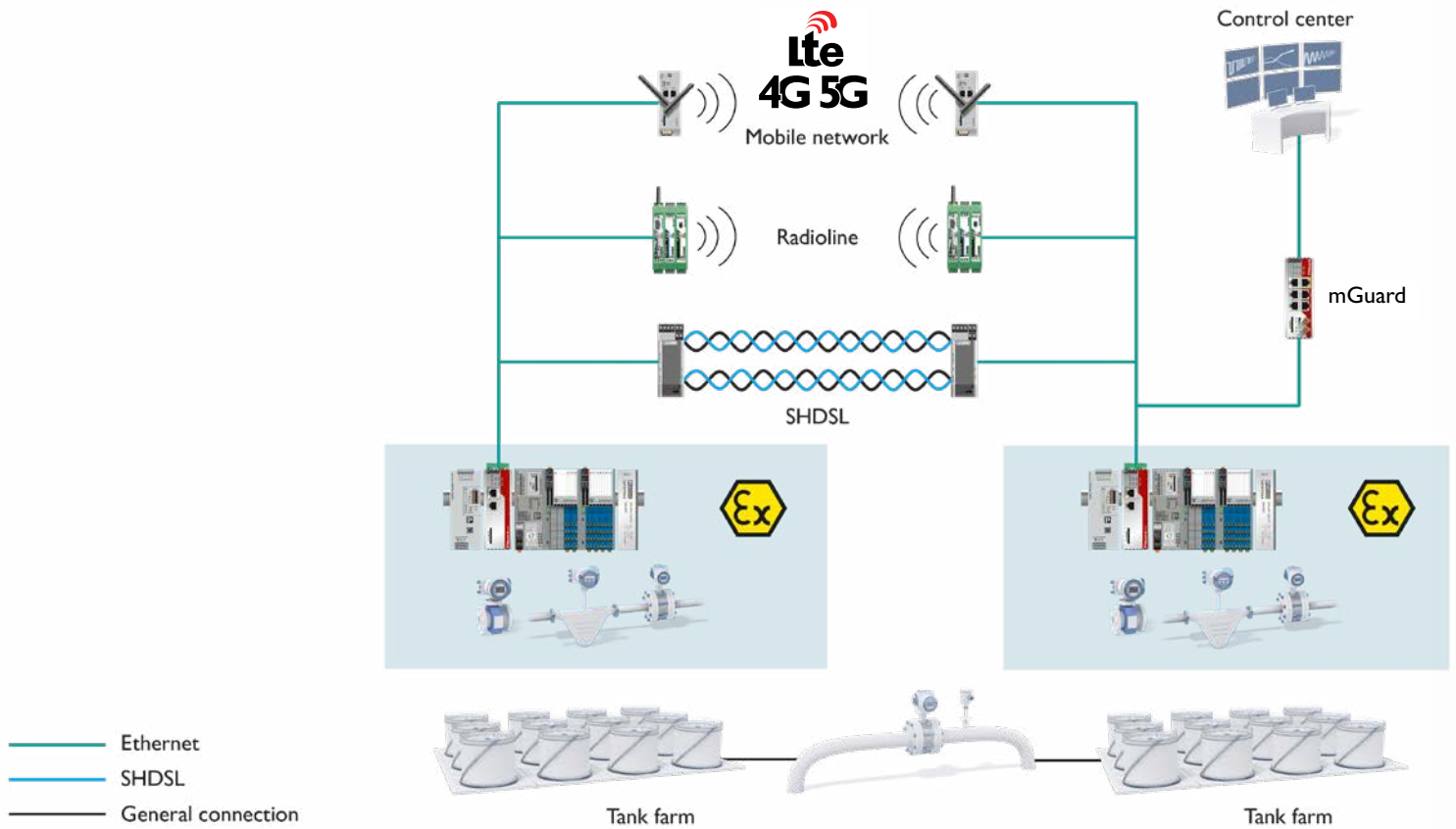

Hydrogen service stations

Automation of service stations

- Remote connection of all sub-modules of a service station
- Modularization and standardization of various interfaces
- Orchestration of the sub-modules
- Reduced engineering effort

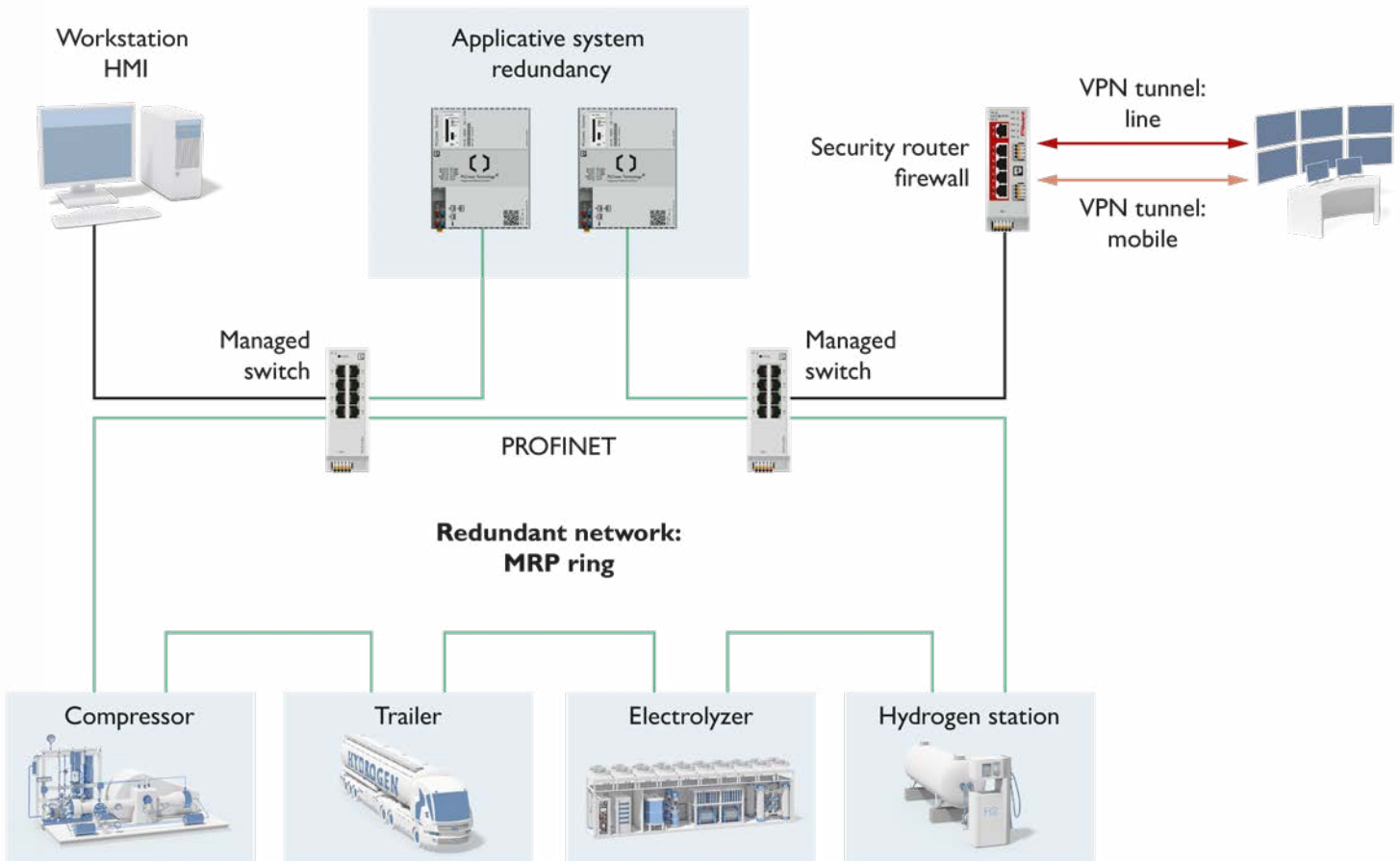

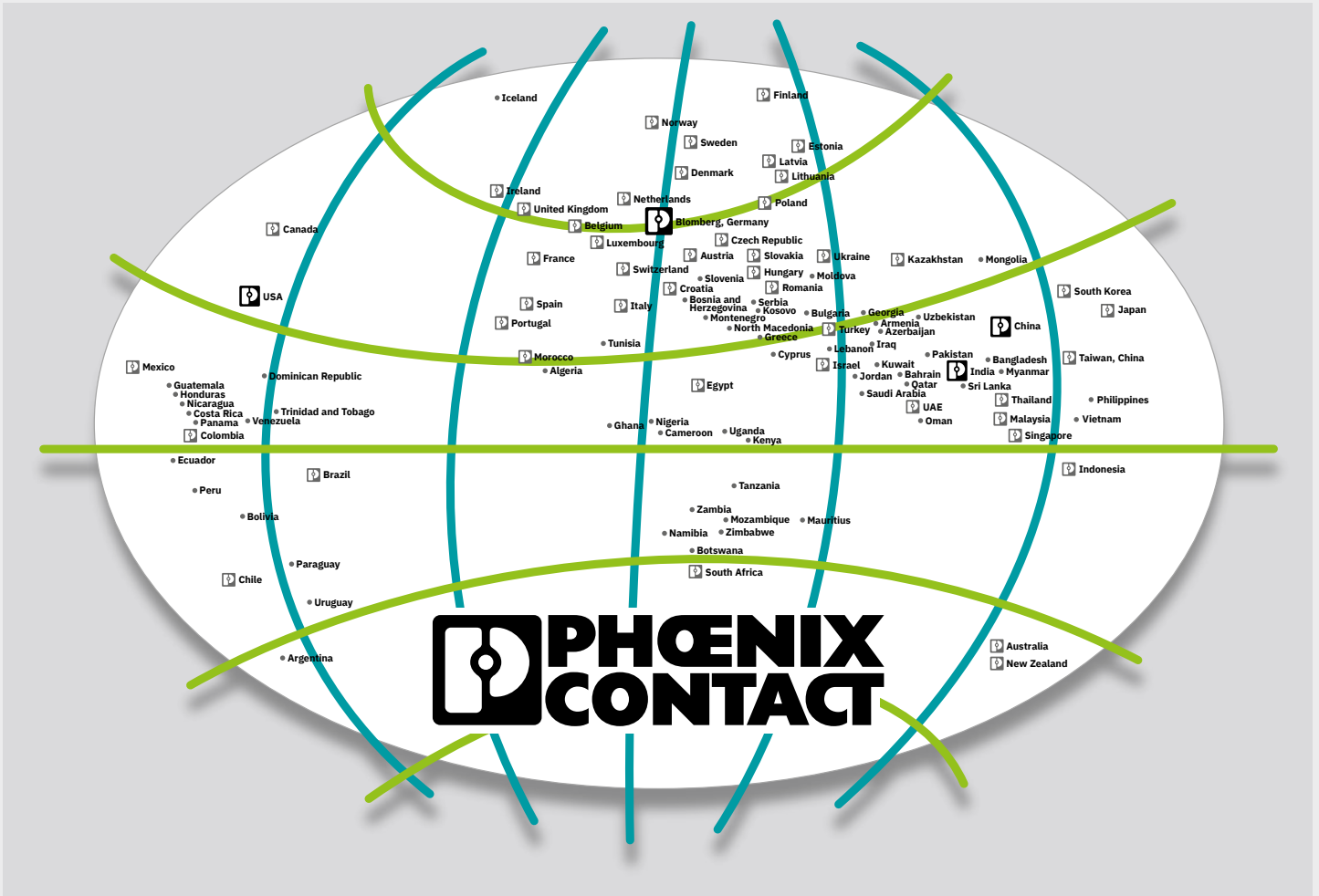

Open communication with customers and partners worldwide

Phoenix Contact is a global market leader based in Germany. We are known for producing future-oriented products and solutions for the electrification, networking, and automation of all sectors of the economy and infrastructure. With a global network reaching across more than 100 countries with over 21,000 employees, we maintain close relationships with our customers, something we believe is essential for our common success.

Our wide range of innovative products makes it easy for our customers to implement the latest technology in a variety of applications and industries. This especially applies to the target markets of energy, infrastructure, industry, and mobility.

You can find your local partner at phoenixcontact.com

