



## 5 things to consider before implementing a UPS

By Ken Allwine, Associate Product Marketing Manager – Power Supplies, Phoenix Contact USA

### Introduction

The Industrial Internet of Things (IIoT) relies on fast and accurate communication of data. These critical control systems cannot afford a momentary power interruption that could cause a PC or controller to crash. Uninterruptible power supply (UPS) solutions can prevent this type of event. This article will help readers understand the basics of choosing and implementing the right UPS for their applications.

While UPS systems come in many form factors and designs, this article focuses on DIN rail-mounted solutions, as they can be used in many applications across multiple industries. (Figure 1)

### 1. Define your application requirements

What types of loads will the UPS be powering – AC or DC?

Legacy systems tend to run on AC power, so retrofits of old systems will likely require AC. In the past 20 years or so, however, the growth of the industrial PC (IPC) market has resulted in a shift to DC power source.

Next, consider the power and runtime requirements. You'll need to calculate the proper sizing of the UPS. This is the point where you need to establish

#### INSIDE:

1. Define your application requirements .... 1
2. Decentralized AC UPS technologies ..... 2
3. Distributed DC UPS solutions ..... 3
4. UPS ... it's all about the batteries! ..... 3
5. The connected UPS ..... 4



**Figure 1:** With the widespread implementation of IIoT and big data in industrial applications, reliable power is more important than ever. Choosing the right UPS system for your application can prevent the problems and costs that a power interruption can cause.

realistic expectations. It is easy to say that a 10 A system needs to run for 48 hours. However, realizing that system can be quite another task.

If a sustained power failure occurs, the UPS's job is to ensure a safe and orderly shutdown of the control platform to avoid data loss, system crashes or malfunctions. When designing the system, it is important to select a battery sized to allow for some amount of runtime before the PC is told to shut off, or if the main power feed is returned in a reasonable time. Oversized battery systems can take an extremely long time to recover the charge.

Batteries are the next step in the equation. While there are many battery choices, most UPS manufacturers use a few industry-standardized types. Some manufacturers will only offer one type of technology, such as valve regulated lead acid (VRLA). Others will offer a variety, such as VRLA and wide-temperature VRLA, as well as lithium iron phosphate (LI-ION). We'll explore batteries in more detail later, but note that different batteries have different performance characteristics and usable service lives.

With most UPSs, the operator has no way of knowing the battery's health, while some UPSs will have a failure indicator – which can be too late if your system is remote. Ideally, a UPS will offer multiple points of health into the battery system, so the operators can take preventive measures before the battery reaches the failure point.

Finally, look at how the UPS communicates these data points. Most UPS solutions use LEDs, and a few options provide dry contact outputs with a fixed threshold point. Newer UPS systems can provide these standards and integrate a full data stream into the control platform. Some systems can now communicate over industrial protocols, such as EtherNet/IP, Profinet, Modbus TCP/IP and EtherCAT.

## 2. Decentralized AC UPS technologies

In control systems that operate on AC voltage, an AC UPS makes the most sense. There are several types of technologies available for an AC UPS.

Offline or standby topology is very straightforward. These products are inexpensive, so they are the most common types of AC UPSs. Under normal conditions, an offline UPS passes the mains power from the input to the output without any interaction other than the battery charging circuit in parallel to the mains circuit. If the mains power fails, the UPS will switch

over from the mains circuit to the battery circuit. The transfer time from when the UPS loses mains until it produces power from the battery cannot exceed 10 milliseconds (ms). The 10 ms transfer usually does not affect downstream devices, but it is important to consider in systems that are sensitive to voltage fluctuations.

Within the offline segment of AC UPS solutions, there are two subsets: modified (simulated) sine-wave output devices and pure sine-wave output devices. These technologies generate the AC output in different ways.

Modified sine-wave devices take the voltage from the battery bank and, in the simplest form, try to create a rough likeness to a sinusoidal wave. While this type of UPS is relatively low-cost, it comes with some disadvantages. The massive steps in voltage can damage the input circuits of the downstream devices. These massive steps also create a high number of switching transients from the UPS's output. Over time, this can lead to premature failure of the small power supplies in industrial PCs and PLCs.

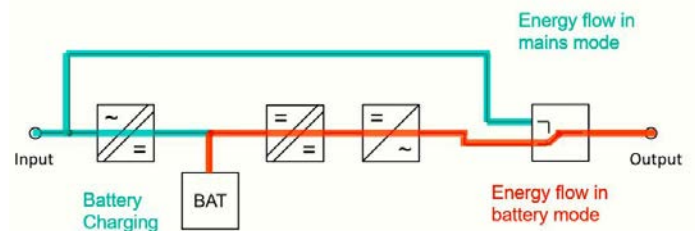
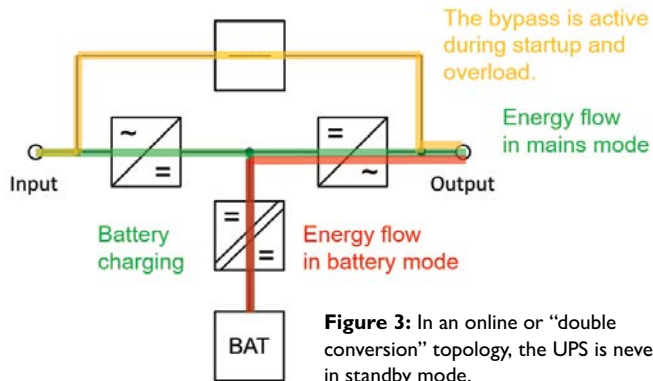

**Figure 2:** In an offline UPS under normal conditions, it simply passes the mains power from the input to the output without any interaction other than the battery charging circuit in parallel to the mains circuit.

A pure sine-wave UPS produces the same sinusoidal waveform output that would replicate the waveform from the 120/230 V mains power feed. The pure sine-wave UPS is the better choice for sensitive control equipment like PLCs, DCSs and IPCs. More circuitry is needed to produce this type of output, so this system is more expensive. However, the investment will usually pay off, as any control devices powered by the UPS will last longer, resulting in a lower total cost of ownership in the long run. (Figure 2)

Mission-critical applications will require an even more advanced UPS, known as double conversion or online UPS solutions. In this topology, the UPS is never in standby mode. The battery circuit is actively connected to the system. If the mains power feed is interrupted, there is no interruption or voltage sag on the output, resulting in seamless battery operation. The online system also has a built-in level of filtration and regulation.

During normal operation, it converts the incoming power feed from AC to DC, and then back again, through an inverter. This level of isolation protects against voltage fluctuations and minor power disturbances on the input side. The higher level of functionality, however, comes with a higher price tag and larger housing.



**Figure 3:** In an online or “double conversion” topology, the UPS is never in standby mode.

### 3. Distributed DC UPS solutions

The drawback of an AC UPS is that everything downstream is AC powered and relies on that singular UPS. A control cabinet application might require a very large AC UPS to power all the downstream devices. If that AC UPS fails, so will all the downstream devices. A distributed DC UPS can save cost and space.

Most of today’s control cabinets are now based on DC voltage. An AC UPS backs up and supports everything at the point of entry. With a DC UPS, the backup occurs after the AC/DC power supply.

With this UPS orientation, you can break the loads into buffered and unbuffered loads. (See below.) The unbuffered loads are the devices that can lose power during a loss of mains voltage and not cause a system failure. The AC/DC power supply can directly power these loads. The DC UPS would power the devices that perform vital functions, or the buffered loads. This can significantly reduce the DC UPS’s load. This amperage reduction equates to the decrease in the size of the UPS and reduces the size of the needed battery capacity. (Figure 3)

DC UPS technology is simpler than AC UPS solutions. DC products do not require AC to DC converters or DC to AC inverters. All the voltages in the UPS remain at nominal safety extra low voltage (SELV) levels of 24 V DC. This is more efficient for both the power supply and the battery bank. Using extra DC/DC converters for other DC voltages uses more current in the conversion and becomes parasitic on the

system. On higher-functioning UPS systems, the only DC conversion that occurs is within the charging circuit for the battery.

A DC UPS system also allows load priority. This prioritizes powering the load connected to the UPS. When a UPS is in the mode of supplying the load in mains mode and charging the battery bank, the UPS will monitor the load current. If the load current and charge current combined would cause an overload of the main AC/DC power supply, the UPS will automatically reduce the charge current, preventing an overload.

DC UPS products also tend to be physically smaller than their AC counterparts because they have simpler circuitry. The smaller size can be valuable in a control cabinet with limited DIN rail space.

Some of these advanced, modular DC UPS systems come with built-in diagnostics. While many UPSs have a “battery OK” or “system fault” indicator, the advanced UPS systems can provide real-time insight on system health and functionality. The maintenance team can review the live data about the battery’s health, voltage level, load current, temperature and more. Instead of guessing about the battery’s health or creating a battery rotation schedule, they have real-time knowledge and can replace the battery before it fails.

### 4. UPS ... it’s all about the batteries!

Batteries are the backbone of a UPS system. When the power goes out, batteries keep things going. So, how can you make sure your battery is not the weak link in your UPS system?

#### Battery types

Common batteries used in industrial applications include:

- Valve-regulated lead acid (VRLA)
- Wide-temperature VRLA
- Lithium-based variants

The standard VRLA battery is the most common for UPS platforms. It is low-cost and strikes a balance between cost and capacity, but it lacks durability. The standard batteries have a nominal operational temperature of 0° to 40°C. They perform best in a room with a steady temperature of about 27°C. While they are common in controlled environments, many industrial applications can see temperatures range from -40° to +70°C. This fluctuation will dramatically reduce the lifespan of VRLA batteries.

Wide-temperature VRLA (WTR-VRLA) can be operated from -25° to +60°C. They also have a slightly longer service life than the standard VRLA. They are often used in outdoor

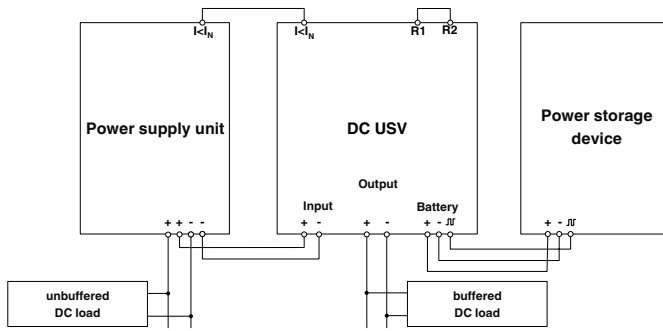

**Figure 4:** With a DC UPS, the backup occurs after the AC/DC power supply. With this UPS orientation, you can break the loads into buffered and unbuffered loads.

applications. Because the chemistry is different than the standard VRLA, the WTR-VRLA is usually larger and comes at a higher price.

Both VRLA and WTR-VRLA batteries can operate for approximately 250 to 300 charge cycles before they fail. This means a VRLA may only last six months, and a WTR-VRLA may last one-and-a-half to two years before needing replacement. (Figure 4)

The lifespan and temperature range of lithium batteries is like that of WTR-VRLA batteries. However, the lithium battery can have up to 7,000 charge cycles – a significant increase in service life. Of course, that comes at a higher price. A lithium battery may cost three times as much as a similar WTR-VRLA. Over the course of a lifetime, however, the lithium battery’s performance often pays for itself. (See table for a comparison of these battery technologies.)

**Table 1: Comparing battery technologies**

Battery type	Temperature	Service life at 20°C	Service life at 50°C	Charge cycles at 20°C	Cost
VRLA	0°...+40°C	6 – 9 years	1 year	250	\$\$
WTR-VRLA	-25°...+60°C	12 years	1.5 year	300	\$\$\$
Lithium-ion	-20°...+58°	15 years	2 years	7,000	\$\$\$\$

### Battery handling

Because batteries are consumable and the voltage degrades even when they are not being used, it is best to purchase and install “just in time” (JIT) to ensure the freshest battery available. If you store batteries, charge them regularly to maintain their voltage. The smaller the battery capacity, the more frequently the batteries need to be energized and recharged.

After a panel builder completes a cabinet, they often forget about it. If the battery sits dormant during transit or storage, it will degrade. If the fuses are not disconnected, parasitic

loads can drain the battery. The ideal solution is to remove the battery from the cabinet after factory acceptance testing and keep that battery as a test battery for multiple cabinets. When you are ready to commission the machine, install a fresh battery.

### 5. The connected UPS

The IIoT means the industrial world is more connected than ever before, making all types of devices smarter. The UPS is no exception. With networking and connectivity, you can have access to your UPS’s performance data at any time or place.

To connect to these UPSs, there must be a network in place. EtherNet/IP, PROFINET and Modbus TCP/IP are among the most common networking protocols for industrial networks in the U.S. A UPS that communicates over these protocols will give the end user visibility into battery performance wherever the UPS is installed. (Figure 5)

A UPS with advanced monitoring and diagnostics can help an engineer or technician make intelligent decisions about UPS or battery maintenance. With warning alarms and real-time information about the battery’s state of health, it’s possible to take a proactive approach to battery maintenance. Having this data readily available eliminates “battery anxiety” and unnecessary maintenance.

UPS systems play a vital role in the health of your control cabinet. With these tips, you are better prepared to choose the UPS system that meets the needs of your application.



**Figure 5:** An intelligent UPS system can connect to the industrial network over protocols like EtherNet/IP, making it easy to get advanced monitoring and diagnostics data about the state of the battery and other important data.

### ABOUT PHOENIX CONTACT

Phoenix Contact is a global market leader based in Germany. Phoenix Contact produces future-oriented components, systems, and solutions for electrical controls, networking, and automation. With a worldwide network reaching across more than 100 countries with over 17,100 employees, Phoenix Contact maintains close relationships with its customers, which are essential for shared success. The company’s wide variety of products makes it easy for engineers to implement the latest technology in various applications and industries. Phoenix Contact focuses on the fields of energy, infrastructure, process, and factory automation.

For more information about Phoenix Contact or its products, visit [www.phoenixcontact.com](http://www.phoenixcontact.com), call **technical service** at **800-322-3225**, or email [info@phoenixcontact.com](mailto:info@phoenixcontact.com).