



Video surveillance for industrial applications

Reliable camera networks for a secure world

Video surveillance for a secure world

Whether you need just a few cameras in a small industrial plant or hundreds of cameras to secure a larger facility, Phoenix Contact provides scalable network solutions that can be easily adapted to your specific video surveillance system.

We analyze your video surveillance network from a holistic perspective. As specialists in all products and services required to connect cameras to video servers, we offer industrial solutions that ensure that no footage is lost. Your video surveillance system is only as secure as the network that connects all of the components.

 Web code: #3133

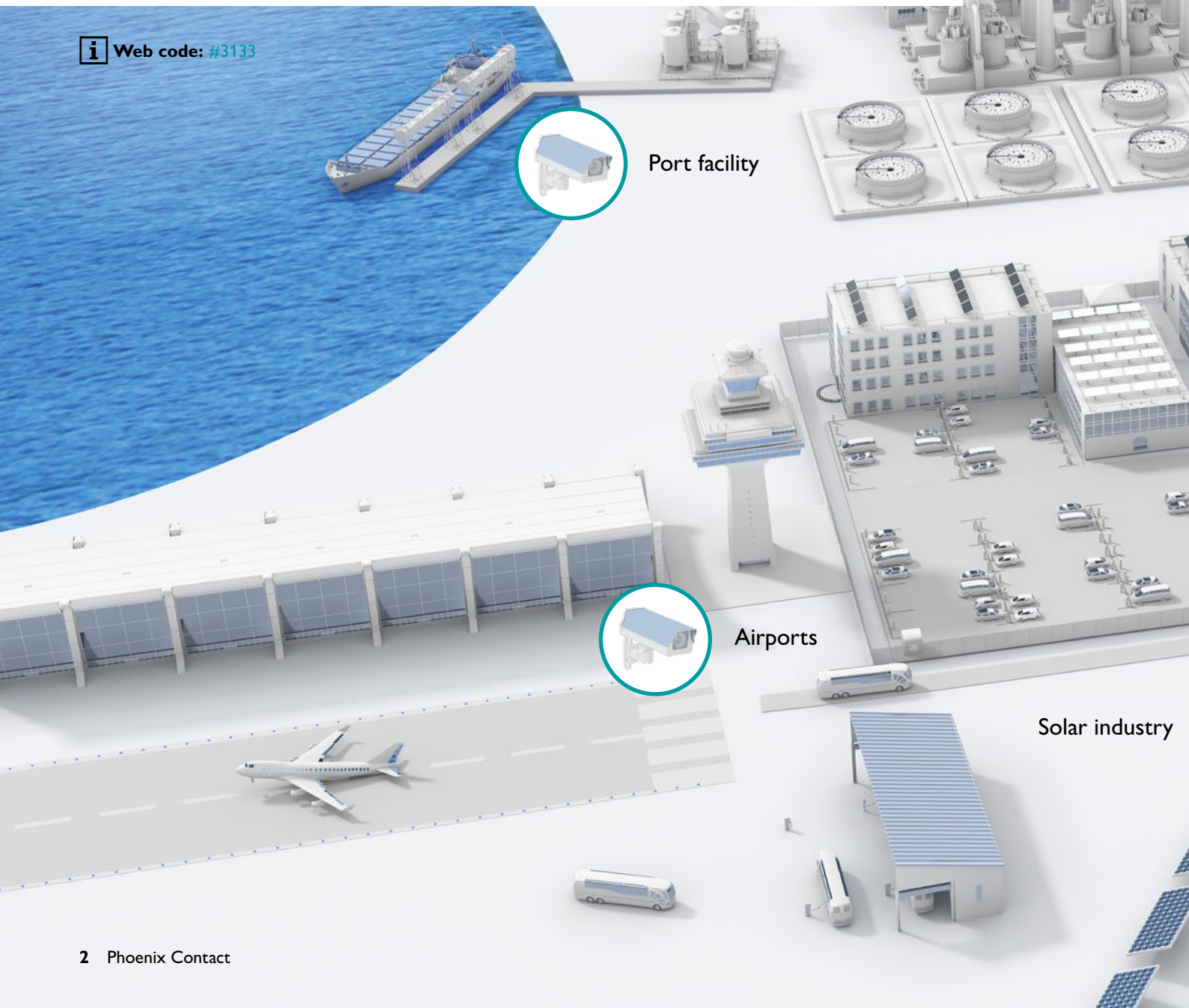

Port facility

Airports

Solar industry

Learn more with the web code

For detailed information, use the web codes provided in this brochure. Simply enter # and the four-digit number in the search field on our website.

 **Web code:** #1234 (example)

Or use the direct link:
phoenixcontact.net/webcode/#1234



Oil and gas



Transportation
technology



Tunnels



Perimeter protection



Smart Ethernet Box – the all-in-one device

The Smart Ethernet Box is an outdoor PoE switch with integrated power supply, surge protection, splice tray for fiber-optic cable, and a DIN rail for additional accessories. Featuring up to four Gigabit Power-over-Ethernet ports and two Uplink ports, the Smart Ethernet Box is the ideal all-in-one device for a large number of applications. These include video surveillance, LED lighting, WLAN access point, and other network applications. This makes it not only perfect for outdoor use, but also ideally suited for demanding industrial and commercial indoor applications.

i Web code: #2458

Your advantages

- ✓ Cost savings with the compact all-in-one device
- ✓ Significant time savings with adapter for wall and mast mounting and minimal wiring effort
- ✓ Advanced PoE management
- ✓ Simple startup and configuration
- ✓ Alarm messages to alert you of sabotage

Smart Ethernet Box at a glance

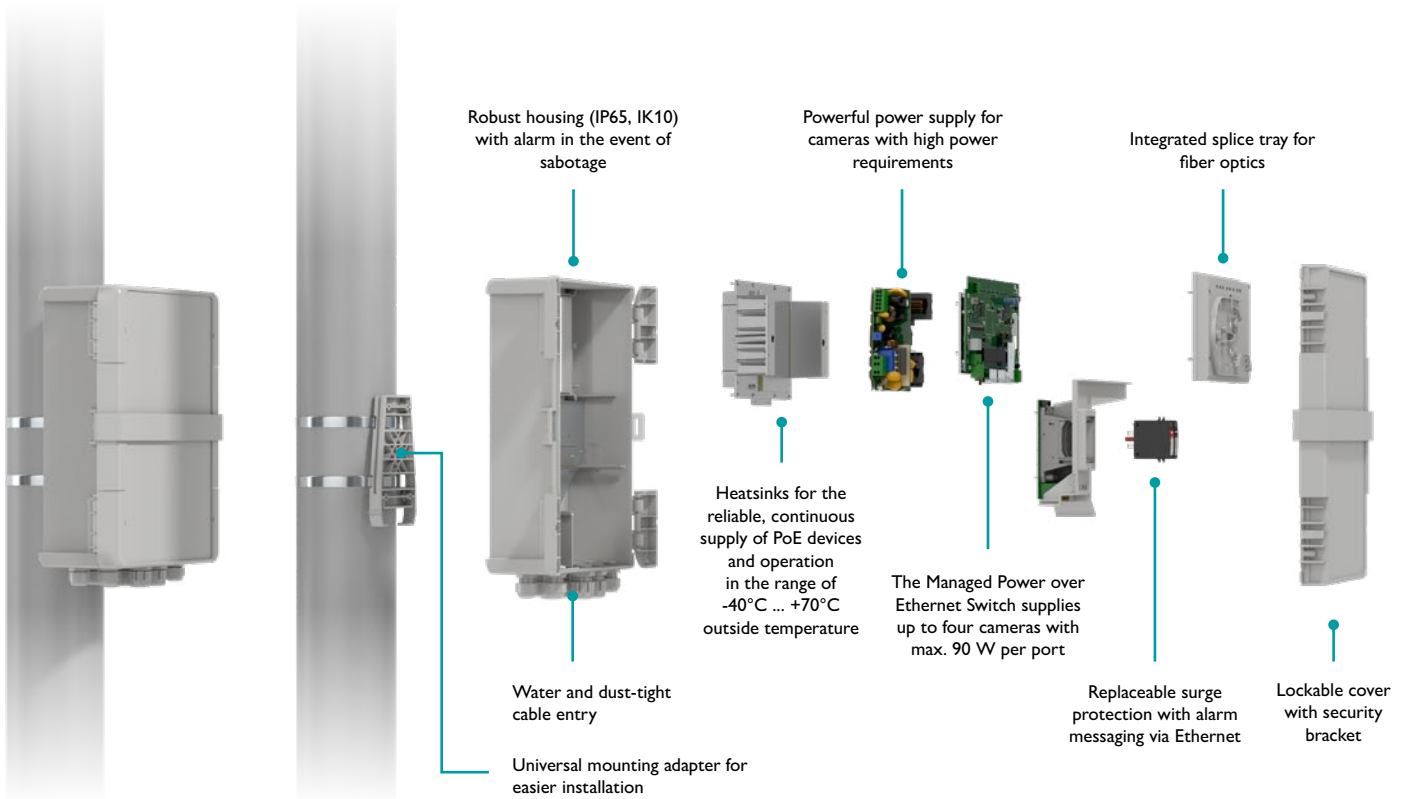

Smart Ethernet Box: small – compact – powerful

The Smart Ethernet Box connects IP surveillance cameras to the video server. It combines the functions of conventional connection boxes in a compact device. This saves planning and wiring time.

The integrated mounting adapter for wall and mast mounting greatly simplifies and accelerates installation. Numerous management and monitoring functions ensure reliable operation of the video system.

If there is an attempt at sabotage, for instance by opening the cover or cutting the camera connection cable, an alarm message is output via the network. This allows you to react quickly to the manipulation or failure of connected devices.

Type	SCX 4POE 2LX	SCX 2POE 2LX	SCX 4POE 2T	SCX 2POE 2T
Uplink ports	2 x FO	2 x FO	2 x copper Ethernet	2 x copper Ethernet
Camera connections	4 x PoE	2 x PoE	4 x PoE	2 x PoE
Item no.	1102626	1108543	1108542	1108544

PoE products for video surveillance

Eliminate the need for a separate power supply when installing devices in difficult to access or remote system parts. With industrial Power over Ethernet (PoE) devices from Phoenix Contact, power supply and data transfer are combined in the same Ethernet cable. Now, this means you can utilize the advantages of PoE technology reliably in critical applications as well. Our portfolio includes all of the components needed to do so, such as power packs, PoE injectors with direct field cable connection, or managed PoE switches with comprehensive monitoring and management options for your system.

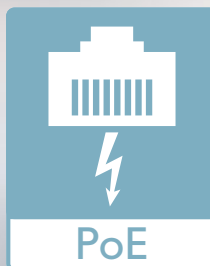

Your advantages

- ✓ Easy device installation, thanks to reduced cabling effort
- ✓ Cross-manufacturer use, thanks to standardization in accordance with IEEE 802.3
- ✓ Fast retrofitting of existing systems thanks to easy handling

Overview of PoE products for video surveillance



PoE injectors

In addition to the RJ45 jack, the PoE injectors feature alternative connection technologies for the field cable and integrated surge protection. The compact stand-alone solution is available in various performance classes up to 60 watts.

i Web code: #1997



Power supplies

The compact UNO POWER power supply ensures the highest availability in PoE applications. With its increased insulation resistance conforming to IEEE 802.3bt, as well as lower EMC emitted interference at the DC output according to EN 61204-3, it offers a high level of data integrity for your application.

i Web code: #1512



PoE switches

The extended temperature range of the managed and unmanaged PoE switches enables reliable operation in harsh environments. In addition, the switches support communication with Jumbo Frames and the simultaneous full utilization of all Gigabit ports. This is specially suited for the high bandwidth requirements of surveillance cameras.

i Web code: #2912

Direct connection to the field cabling

The PoE injectors have a direct field cable connection. This means the cable carrying PoE can be easily and directly connected via screw connection, IDC, or push-in.

Thanks to simple connection of the cable to the injector, complex installation of an RJ45 connector or use of a separate patch panel can be eliminated. This saves costs and space on the DIN rail.

The integrated surge protection and electrical isolation protect the connected devices against surges and short circuits. No additional protective components are required.

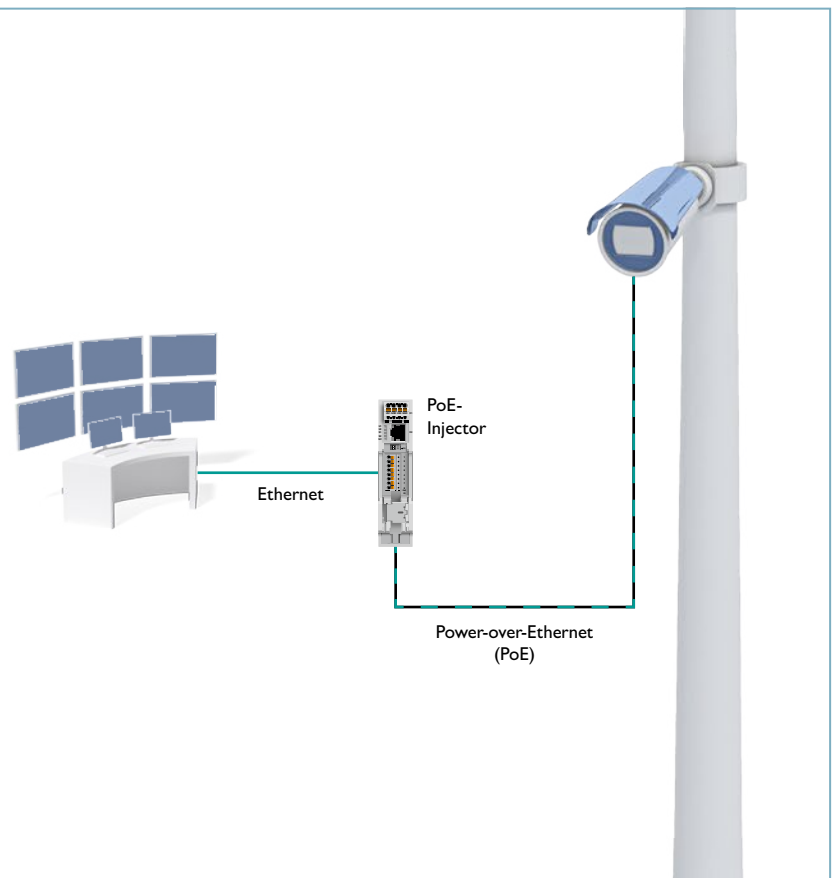

Highspeed Ethernet up to 1 km Gigabit Ethernet extender

The Gigabit extenders enable broadband Gigabit applications over 2-wire cables and coaxial cables up to 1 km. Use existing cables for demanding Ethernet applications and minimize the investment costs of your installation. With the Power-over-Link (PoL) and Power-over-Ethernet (PoE) functions, you supply the entire network and connected devices with power via the data lines.

 Web code: #3132

Your advantages

- ✓ High bandwidth and range for Ethernet networks (1 Gbps – up to 1 km)
- ✓ Use of existing 2-wire cables or coaxial cables
- ✓ Power-over-Link (PoL) – power supply for the Gigabit extenders via 2-wire cables and coaxial cables
- ✓ Power-over-Ethernet (PoE) – Power supply for the PoE end devices
- ✓ Flexible network configuration

Overview of Gigabit Ethernet extenders:

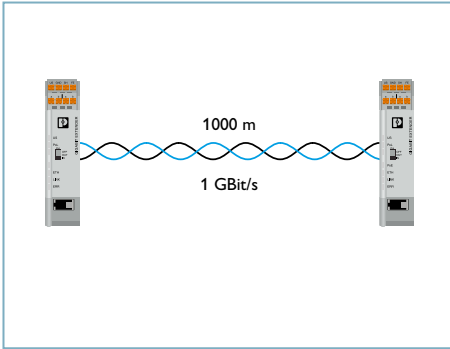

Long distances and high bandwidth

The Gigabit Ethernet extenders enable broadband Ethernet applications up to 1 Gbps over distances up to 1 km. No CAT Ethernet cable is needed. Twisted 2-wire cables or coaxial cables are used for robust transmission.

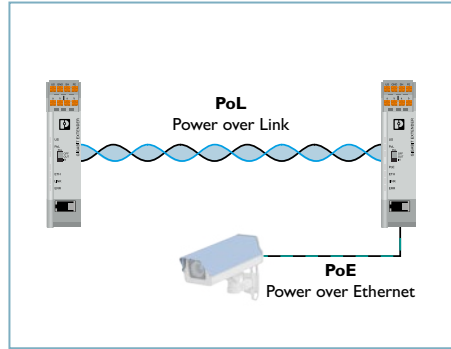

Power transmission

With the PoL and PoE function, the Gigabit Ethernet extenders themselves and also the connected PoE end devices are supplied with voltage via the data cable. Depending on the network structure, multiple Gigabit Ethernet extenders and PoE end devices require just one power supply. This results in a large cost reduction due to fewer devices and less installation work.

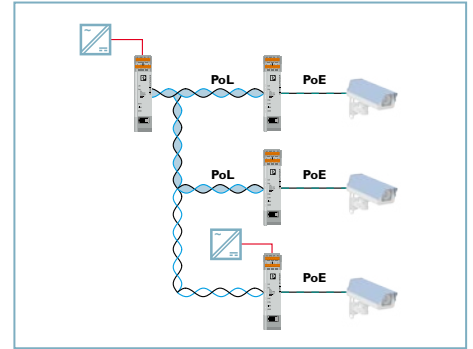

Flexible network configuration

You can use the Gigabit Ethernet extender in a point-to-point connection or with multiple devices in one network. Line, star, tree, or ring structures are possible. This increases the flexibility of the application. The Plug and Play-capable devices detect one another automatically and enable the easy startup of your system without complex configuration.

Ethernet transmission beyond previous limits

Gigabit Ethernet extenders transmit broadband Ethernet up to 1 km, which is significantly farther than the maximum standard Ethernet distance of 100 m. And they do so without a CAT-suitable Ethernet

cable. Robust transmission is handled using 2-wire cables or coaxial cables, which are frequently used in video surveillance. This means they are particularly well-suited for retrofits of analog to digital video

surveillance. In addition, they are designed for all Ethernet applications where large ranges in network extent pose a challenge.

EXTENDER 1010 ETH COAX-G	... 2010 ETH COAX-G	... 1010 ETH TP-G	... 2010 ETH TP-G
Range	Up to 1 km	Up to 1 km	Up to 1 km	Up to 1 km
Bandwidth	Up to 1 Gbps	Up to 1 Gbps	Up to 1 Gbps	Up to 1 Gbps
Cable type	Coaxial cables	Coaxial cables	2-wire cable	2-wire cable
Connection	BNC female connector	BNC female connector	Push-in terminal block	Push-in terminal block
Supply functions	PoL	PoL and PoE	PoL	PoL and PoE
Item no.	1319319	1319320	1319321	1319322

Modular solution with individual components

Reliable video security systems: We can help you configure high-availability data and supply networks for your video surveillance application.

As the basis for these networks, Phoenix Contact provides a broad range of industrial connection and communication technology products that can be combined to create an application-oriented solution to connect your cameras and video server.

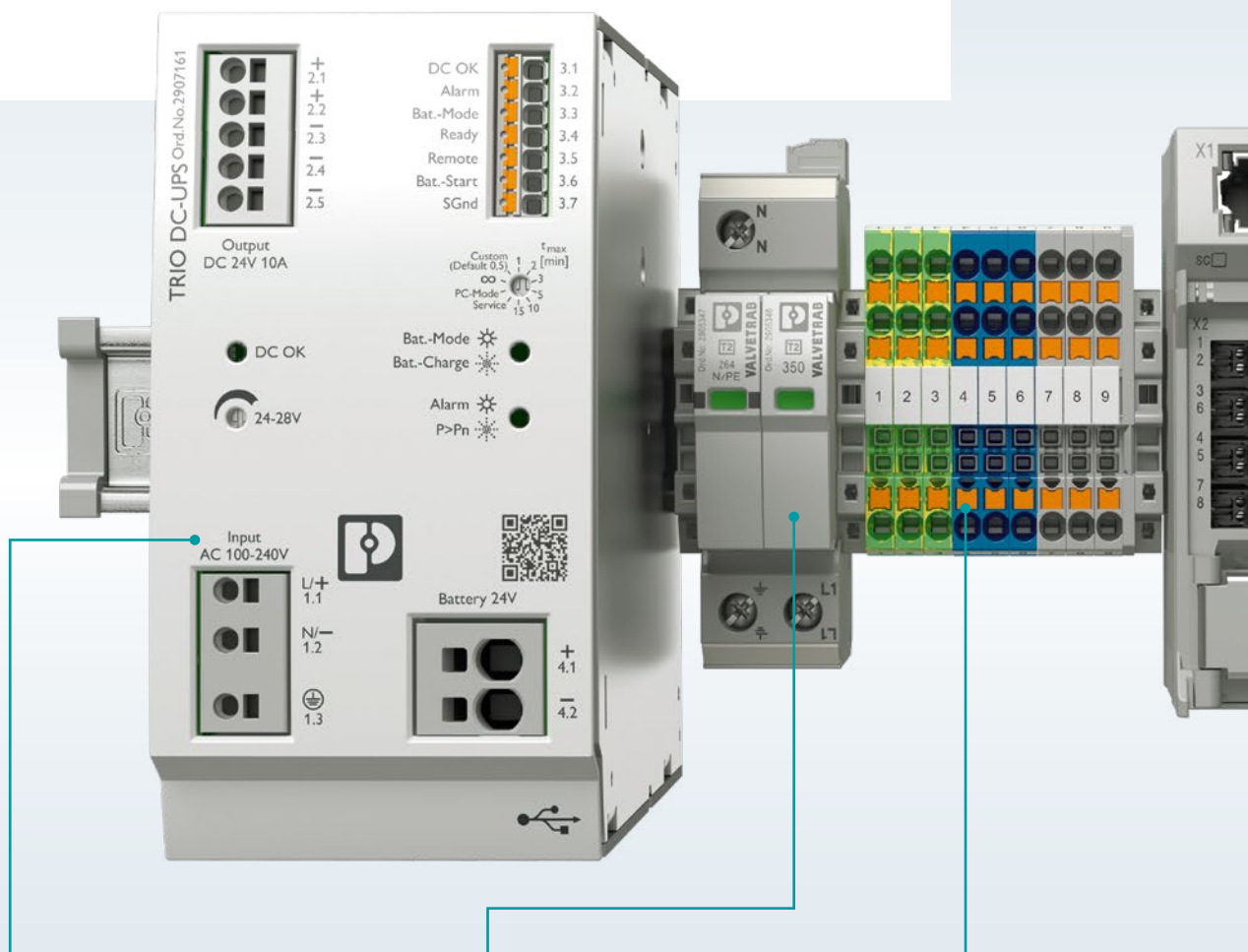

Power supplies and UPS

From 5 V to 48 V and with different designs, outputs, and functions.

i Web code: [#1985](#)

Surge protection

Avoid the expense of repairs and system downtimes, as well as the loss of important footage and data.

i Web code: [#0291](#)

Terminal blocks

Terminal blocks with Push-in connection technology for use in harsh environments.

i Web code: [#0567](#)

19-inch components for your video control room

Create a reliable connection between your camera applications and the video control room.

i Web code: #2303

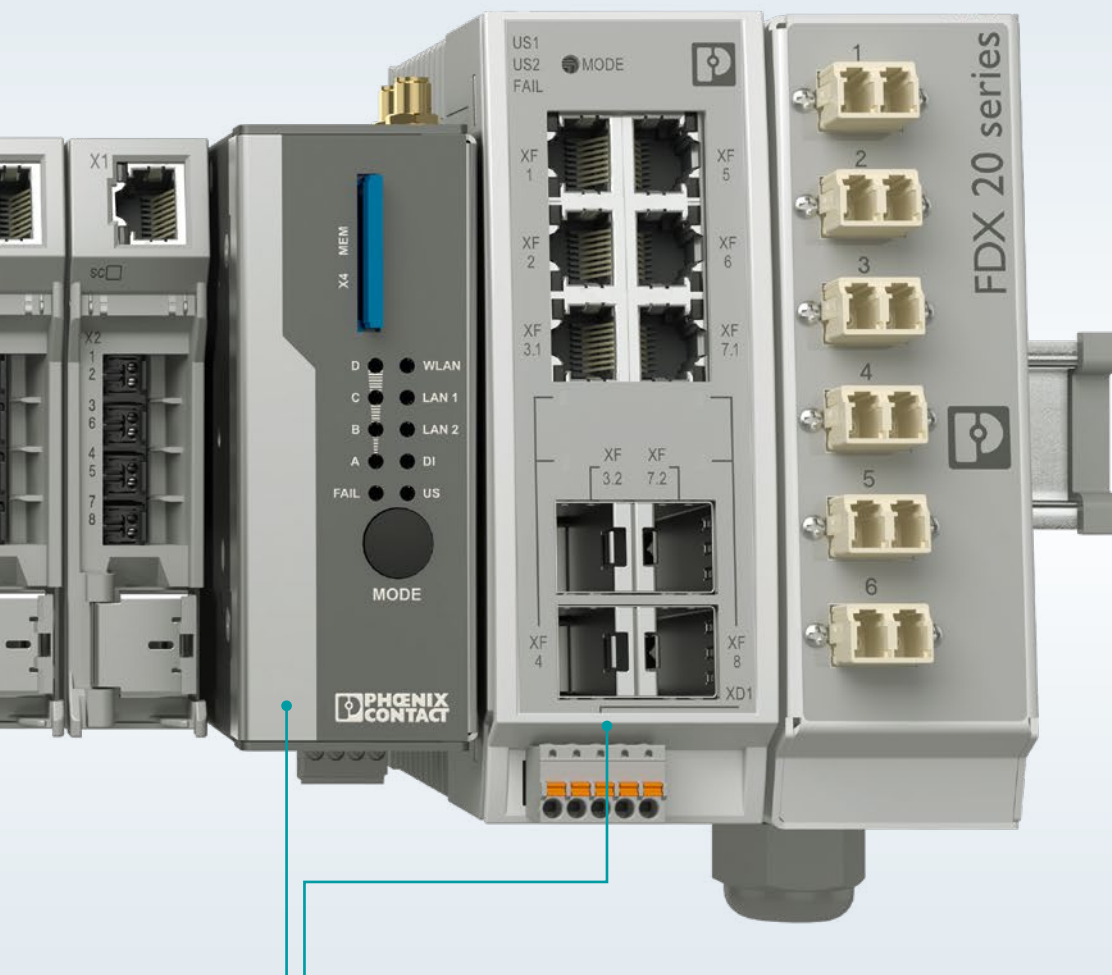

Industrial Ethernet

Network products such as managed and unmanaged switches for reliable operation in critical surveillance networks.

i Web code: #0956

Connectors

Pre-assembled connectors and connectors for assembly for copper and fiber-optic-based applications.

i Web code: #0515

Cables and lines

Pre-assembled lines for a secure connection both indoors and outdoors.

i Web code: #1411

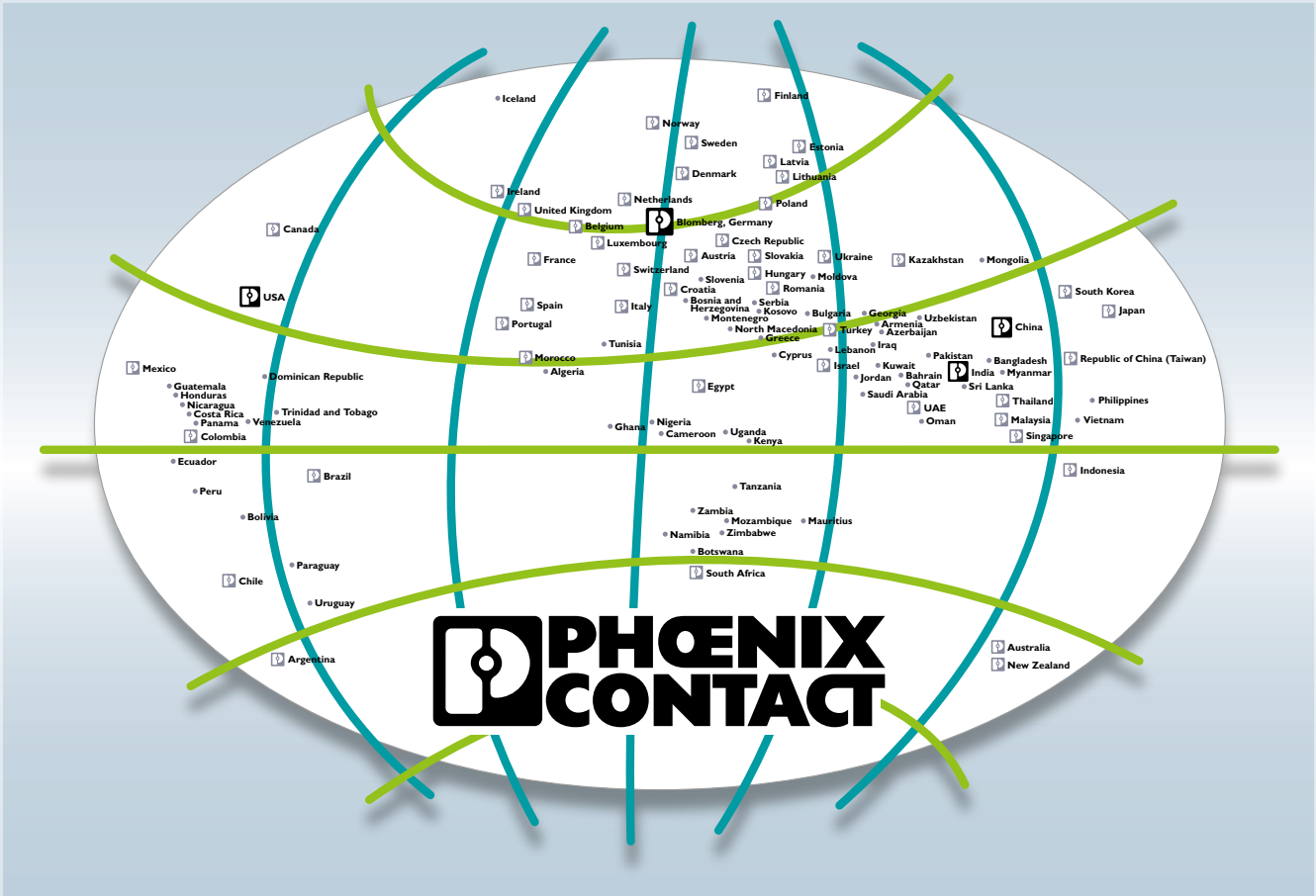

Open communication with customers and partners worldwide

Phoenix Contact is a global market leader based in Germany. We are known for producing future-oriented products and solutions for the electrification, networking, and automation of all sectors of the economy and infrastructure. With a global network reaching across more than 100 countries with over 22,000 employees, we maintain close relationships with our customers, something we believe is essential for our common success.

Our wide range of innovative products makes it easy for our customers to implement the latest technology in a variety of applications and industries. This especially applies to the target markets of energy, infrastructure, industry, and mobility.

You can find your local partner at

phoenixcontact.com