









## ESSENTIAL edition

Phoenix Contact  
Australia and New Zealand

# Table of contents

---

Redundancy modules	
Page 3	
Power supplies	
Page 7	
Surge protection and lightning protection	
Page 15	
Terminal blocks	
Page 22	
Industrial communication	
Page 58	
Signal conditioners and measuring transducers	
Page 64	
Safety relay modules and sensors	
Page 69	
Relays and optocouplers	

---

# Redundancy modules



## Redundancy modules

A redundancy module is used to decouple two power supplies and ensures the high availability and productivity of your system. A redundant power supply is particularly necessary in applications with stringent demands regarding operational safety. A redundant system ensures that the failure of one power supply unit does not result in system downtime.

## Product range overview

---

Redundancy modules ESSENTIAL edition

---

**6**

## Safe decoupling



When the ESSENTIAL edition redundancy modules are used, two power supplies can be decoupled from each other for 100% redundancy. This enables a high degree of operational safety.



### Increased performance

The redundancy modules are the ideal choice for an easy and reliable increase in performance of power supplies of the same type that are connected in parallel.



### Comprehensive signaling

The redundancy modules offer comprehensive status signaling. DC-OK LEDs and floating switching contacts enable consistent state monitoring.

### Your advantages:

- Worldwide use with international approval package
- High flexibility with a wide range input from 10 V DC ... 60 V DC
- Extensive monitoring with channel-specific status LEDs and floating switching contacts
- Extremely attractive costs

**Redundancy modules ESSENTIAL edition**



When the ESSENTIAL edition redundancy modules are used, two power supplies can be decoupled from each other for 100% redundancy. This enables a high degree of operational safety.

**ESSENTIAL DIODE, Screw connection, 12 V DC ... 48 V DC, 2x 10 A DC, 1x 20 A DC**



Technical data	
Approvals	CB
Input voltage range	10 V DC ... 60 V DC
Output current	20 A
Type of decoupling	passive
Width	40 mm
Height	124 mm
Depth	126 mm

Type	Item No.
PS-EE-2G-DIODE/12-48DC/2X10/SC	<a href="#">1584245</a>

**ESSENTIAL DIODE, Screw connection, 12 V DC ... 48 V DC, 2x 20 A DC, 1x 40 A DC**



Technical data	
Approvals	CB
Input voltage range	10 V DC ... 60 V DC
Output current	40 A
Type of decoupling	passive
Width	40 mm
Height	124 mm
Depth	126 mm

Type	Item No.
PS-EE-2G-DIODE/12-48DC/2X20/SC	<a href="#">1584246</a>

# Power supplies



## Power supplies

Phoenix Contact offers a broad portfolio of power supplies for various applications. With a wide range of performance classes and functions to choose from, you will find the ideal industrial solution for machine building, the semiconductor industry, or control cabinet building, for example.

## Product range overview

---

Power supplies ESSENTIAL edition

---

**11**

## Reliable supply



The power supplies in the ESSENTIAL edition family are the ideal choice for supplying your system reliably using basic functions. They meet essential industry standards and also offer additional features at an attractive price. These include an international approval package, wide temperature range, and flexible wide range input. ESSENTIAL edition is therefore ideally suited for worldwide use.



### Vibration and shock resistance

The robust design of the mechanical and electrical components tolerates sustained vibrations of up to 2.3g in resonance and shocks of up to 15g for 15 ms.



### Self-protecting

Various protective mechanisms ensure comprehensive device protection at all times. Internal protective circuits take effect in the event of an overvoltage, overcurrent, or excessively high temperature. The device protects itself from any harm.

### Your advantages:

- Worldwide application, thanks to the wide range input and international approval package
- Immunity to voltage dips at the output with the SEMI-F47 standard
- Greater availability, thanks to fan-free convention cooling

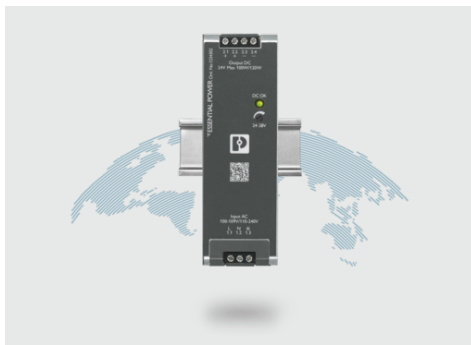

### For universal use

Thanks to the international approval package and wide range input, the power supplies can be used worldwide.



### Fanless convection cooling

The ESSENTIAL edition power supplies feature a fanless convection cooling system. This provides greater availability for your application.



### Fast installation

The preinstalled DIN rail adapter enables quick and easy installation of the device on the DIN rail.



### Optimally coordinated

The ESSENTIAL edition power supplies harmonize perfectly with the surge protection from the same family. Their combination further increases device protection, service life, and system availability.

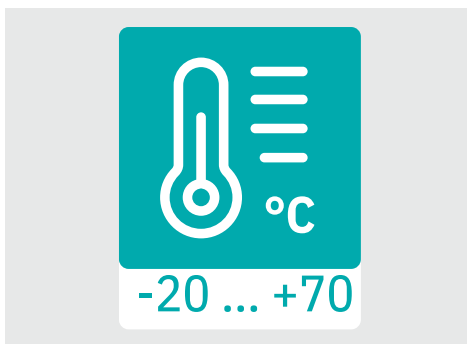

### Wide temperature range

The ESSENTIAL edition power supplies have a wide temperature range from 20°C to +70°C. Combined with built-in temperature monitoring, this ensures reliable use even in adverse temperature conditions.



### Transformer standard

The installed transformers conform to the safety standard of the IEC 61558-2-16 transformer standard, which eliminates the need for an additional safety transformer.

Power supplies ESSENTIAL edition



The power supplies in the ESSENTIAL edition family are the ideal choice for supplying your system reliably. They meet essential industry standards and also offer additional features at an attractive price. These include an international approval package, wide temperature range, and flexible wide range input. ESSENTIAL edition is therefore ideally suited for worldwide use.

**ESSENTIAL POWER, 1-phase, Screw connection, 24 V DC, 2,5 A, 60 W**



Technical data	
Approvals	BIS Licence Document
Input voltage range	85 V AC ... 264 V AC
Output voltage range	24 V DC ... 28 V DC (> 24 V DC, constant capacity restricted)
Output voltage	24 V DC
Output current	max. 2.5 A
Nominal power	60 W (240 V AC)
Connection method	Screw connection
Protective coating	no
Degree of protection	IP20
Width	33 mm
Height	90 mm
Depth	100 mm
Number of phases	1
<b>Type</b>	
PS-EE-2G/1AC/24DC/60W/SC	
<b>Item No.</b>	
1394764	

**ESSENTIAL POWER, 1-phase, Screw connection, 24 V DC, 3,125 A, 75 W**



Technical data	
Approvals	BIS Licence Document
Input voltage range	85 V AC ... 264 V AC
Output voltage range	24 V DC ... 28 V DC (> 24 V DC, constant capacity restricted)
Output voltage	24 V DC
Output current (IN_PMax)	max. 3.125 A (P <sub>N</sub> = 75 W)
Nominal power	75 W (240 V AC)
Connection method	Screw connection
Protective coating	no
Degree of protection	IP20
Width	33 mm
Height	90 mm
Depth	100 mm
Number of phases	1
<b>Type</b>	
PS-EE-2G/1AC/24DC/75W/SC	
<b>Item No.</b>	
1234301	

**ESSENTIAL POWER, 1-phase, Screw connection, 12 V DC, 6,25 A, 75 W**



Technical data	
Approvals	
Input voltage range	85 V AC ... 264 V AC
Output voltage range	12 V DC ... 15 V DC (> 12 V DC, constant capacity restricted)
Output voltage	12 V DC
Output current (IN_PMax)	max. 6.25 A (P <sub>N</sub> = 75 W)
Nominal power	75 W (240 V AC)
Connection method	Screw connection
Protective coating	no
Degree of protection	IP20
Width	33 mm
Height	90 mm
Depth	100 mm
Number of phases	1
<b>Type</b>	
PS-EE-2G/1AC/12DC/75W/SC	
<b>Item No.</b>	
1585280	

**ESSENTIAL POWER, 1-phase, Screw connection, 48 V DC, 2,5 A, 120 W**



Technical data	
Approvals	
Input voltage range	85 V AC ... 264 V AC
Output voltage range	48 V DC ... 57 V DC (> 48 V DC, constant capacity restricted)
Output voltage	48 V DC
Output current (IN_PMax)	max. 2.5 A (PN = 120 W)
Nominal power	120 W (240 V AC)
Connection method	Screw connection
Degree of protection	IP20
Width	40 mm
Height	124 mm
Depth	125 mm
Number of phases	1

Type	Item No.
PS-EE-2G/1AC/48DC/120W/SC	1585285

**ESSENTIAL POWER, 1-phase, Screw connection, 24 V DC, 5 A, 120 W**



Technical data	
Approvals	BIS Licence Document
Input voltage range	85 V AC ... 264 V AC
Output voltage range	24 V DC ... 28 V DC (> 24 V DC, constant capacity restricted)
Output voltage	24 V DC
Output current (IN_PMax)	max. 5 A (PN = 120 W)
Nominal power	120 W (240 V AC)
Connection method	Screw connection
Protective coating	no
Degree of protection	IP20
Width	40 mm
Height	124 mm
Depth	125 mm
Number of phases	1

Type	Item No.
PS-EE-2G/1AC/24DC/120W/SC	1234302

**ESSENTIAL POWER, 1-phase, Screw connection, 12 V DC, 10 A, 120 W**



Technical data	
Approvals	
Input voltage range	85 V AC ... 264 V AC
Output voltage range	12 V DC ... 15 V DC (> 12 V DC, constant capacity restricted)
Output voltage	12 V DC
Output current (IN_PMax)	max. 10 A (PN = 120 W)
Nominal power	120 W (240 V AC)
Connection method	Screw connection
Degree of protection	IP20
Width	40 mm
Height	124 mm
Depth	125 mm
Number of phases	1

Type	Item No.
PS-EE-2G/1AC/12DC/120W/SC	1585283

**ESSENTIAL POWER, 1-phase, Screw connection, 48 V DC, 5 A, 240 W**



Technical data	
Approvals	
Input voltage range	85 V AC ... 264 V AC
Output voltage range	48 V DC ... 57 V DC (> 48 V DC, constant capacity restricted)
Output voltage	48 V DC
Output current (IN_PMax)	max. 5 A (PN = 240 W)
Nominal power	240 W (240 V AC)
Connection method	Screw connection
Degree of protection	IP20
Width	60 mm
Height	124 mm
Depth	125 mm
Number of phases	1

Type	Item No.
PS-EE-2G/1AC/48DC/240W/SC	1585286

**ESSENTIAL POWER, 1-phase, Screw connection, 24 V DC, 10 A, 240 W**



Technical data	
Approvals	BIS Licence Document
Input voltage range	85 V AC ... 264 V AC
Output voltage range	24 V DC ... 28 V DC (> 24 V DC, constant capacity restricted)
Output voltage	24 V DC
Output current (IN_PMax)	max. 10 A (PN = 240 W)
Nominal power	240 W (240 V AC)
Connection method	Screw connection
Protective coating	no
Degree of protection	IP20
Width	60 mm
Height	124 mm
Depth	125 mm
Number of phases	1
<b>Type</b>	PS-EE-2G/1AC/24DC/240W/SC
<b>Item No.</b>	1234304

**ESSENTIAL POWER, 1-phase, Screw connection, 12 V DC, 20 A, 240 W**



Technical data	
Approvals	
Input voltage range	85 V AC ... 264 V AC
Output voltage range	12 V DC ... 15 V DC (> 12 V DC, constant capacity restricted)
Output voltage	12 V DC
Output current (IN_PMax)	max. 20 A (PN = 240 W)
Nominal power	240 W (240 V AC)
Connection method	Screw connection
Degree of protection	IP20
Width	60 mm
Height	124 mm
Depth	125 mm
Number of phases	1
<b>Type</b>	PS-EE-2G/1AC/12DC/240W/SC
<b>Item No.</b>	1585284

**ESSENTIAL POWER, 1-phase, Screw connection, 48 V DC, 10 A, 480 W**



Technical data	
Approvals	
Input voltage range	85 V AC ... 264 V AC
Output voltage range	48 V DC ... 57 V DC (> 48 V DC, constant capacity restricted)
Output voltage	48 V DC
Output current (IN_PMax)	max. 10 A (PN = 480 W)
Nominal power	480 W (240 V AC)
Connection method	Screw connection
Protective coating	no
Degree of protection	IP20
Width	86 mm
Height	124 mm
Depth	125 mm
Number of phases	1
<b>Type</b>	PS-EE-2G/1AC/48DC/480W/SC
<b>Item No.</b>	1585287

**ESSENTIAL POWER, 1-phase, Screw connection, 24 V DC, 20 A, 480 W**



Technical data	
Approvals	BIS Licence Document
Input voltage range	85 V AC ... 264 V AC
Output voltage range	24 V DC ... 28 V DC (> 24 V DC, constant capacity restricted)
Output voltage	24 V DC
Output current (IN_PMax)	max. 20 A (PN = 480 W)
Nominal power	480 W (240 V AC)
Connection method	Screw connection
Protective coating	no
Degree of protection	IP20
Width	86 mm
Height	124 mm
Depth	125 mm
Number of phases	1
<b>Type</b>	PS-EE-2G/1AC/24DC/480W/SC
<b>Item No.</b>	1234308

**ESSENTIAL POWER, 3-phase, Screw connection, 24 V DC, 10 A, 240 W**



Technical data	
Approvals	CB
Input voltage range	3x 320 V AC ... 575 V AC
Output voltage range	22.5 V DC ... 29.5 V DC (> 24 V DC, constant capacity restricted)
Output voltage	24 V DC $\pm$ 1 %
Output current	10 A ( $U_{OUT}$ = 24 V DC)
Nominal power ( $P_N$ )	240 W
Connection method	Screw connection
Protective coating	no
Degree of protection	IP20
Width	60 mm
Height	130 mm
Depth	152.5 mm
Number of phases	3

Type	Item No.
ESSENTIAL-PS/3AC/24DC/240W/EE	1018291

**ESSENTIAL POWER, 3-phase, Screw connection, 24 V DC, 20 A, 480 W**



Technical data	
Approvals	CB
Input voltage range	3x 320 V AC ... 575 V AC
Output voltage range	22.5 V DC ... 29.5 V DC (> 24 V DC, constant capacity restricted)
Output voltage	24 V DC $\pm$ 1 %
Output current	20 A ( $U_{OUT}$ = 24 V DC)
Nominal power ( $P_N$ )	480 W
Connection method	Screw connection
Protective coating	no
Degree of protection	IP20
Width	115 mm
Height	130 mm
Depth	152.5 mm
Number of phases	3

Type	Item No.
ESSENTIAL-PS/3AC/24DC/480W/EE	1018299

**ESSENTIAL POWER, 3-phase, Screw connection, 24 V DC, 40 A, 960 W**



Technical data	
Approvals	CB
Input voltage range	3x 320 V AC ... 575 V AC
Output voltage range	22.5 V DC ... 29.5 V DC (> 24 V DC, constant capacity restricted)
Output voltage	24 V DC $\pm$ 1 %
Output current	40 A ( $U_{OUT}$ = 24 V DC)
Nominal power ( $P_N$ )	960 W
Connection method	Screw connection
Protective coating	no
Degree of protection	IP20
Width	139 mm
Height	130 mm
Depth	190 mm
Number of phases	3

Type	Item No.
ESSENTIAL-PS/3AC/24DC/960W/EE	1018294

# Surge protection and lightning protection

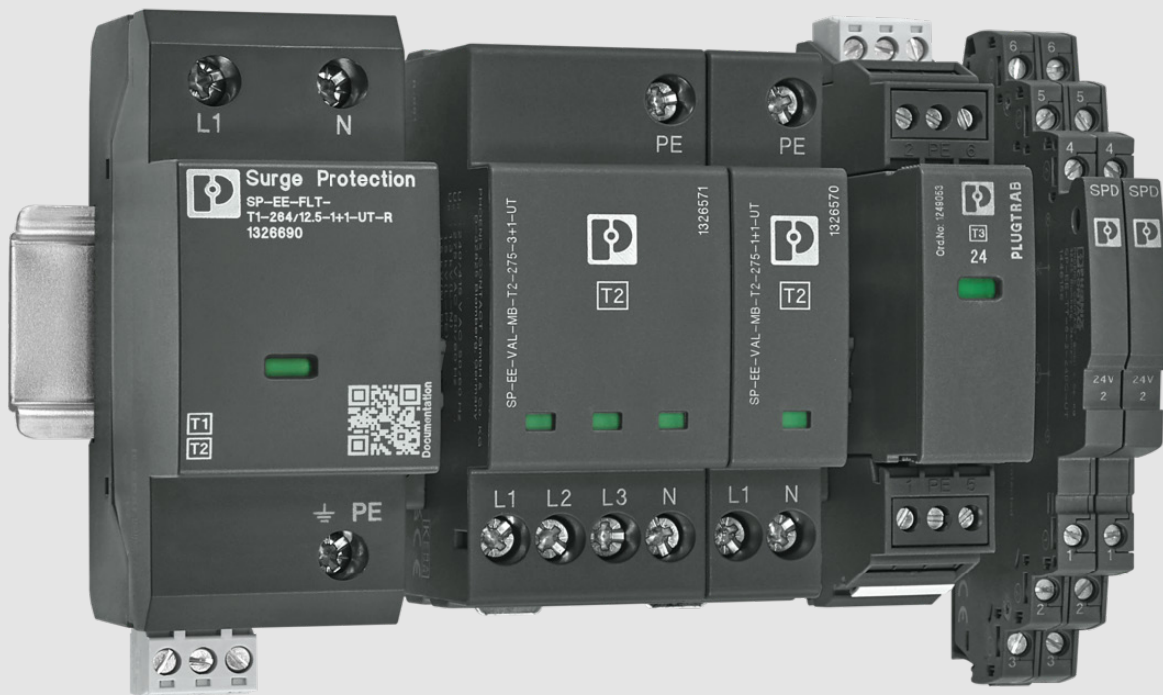

## Surge protection and lightning protection

Lightning currents and surge voltages can cause damage to devices and components. In the worst case, the entire system may even fail. Downtimes and repairs further lead to high costs. Businesses in every industry require a high degree of system availability. With individualized solutions for requirements in a wide variety of applications, reliable surge protection by Phoenix Contact makes a significant contribution.

## Product range overview

---

Surge protection for power supply ESSENTIAL edition **19**

---

## Powerful and durable



The surge protective devices are subjected to a large number of tests and examinations during their development phase in the in-house, certified pulse and high-current laboratory. A special feature of this laboratory is a powerful power supply system that can be coupled with a surge current generator. Thus, an environment is created in which surge protective devices can be tested intensively under challenging conditions.



### Basic research

The foundation for a high-quality product is basic research and technological development. New technologies and materials for surge protection are developed and made usable with specific targets in mind.



### Development and production

In a dialog between development and production, components and materials are harmonized to create a robust, reliable and powerful product. It is ensured that the high requirements on a reliable and effective protective device are satisfied at all times.



### Quality tests

Standardized quality tests are performed throughout production and thus guarantee products of the highest levels of quality and safety.



### Combined protective devices, type 1+2

SP-EE-FLT is suitable for universal use in TN and TT networks and meets the requirements of lightning protection levels III and IV. The encapsulated spark gap, which is free of leakage current and line follow current, limits lightning-related voltage peaks and switching overvoltages to the level of overvoltage category II. It can therefore be used in the unmetred area.



### Surge protective devices, type 2

The devices are usually installed in sub-distributions or control cabinets. These devices must be able to discharge induced surge voltages from direct lightning strikes or switching operations, but do not have to handle direct lightning currents. In any case, induced surge voltages caused by switching operations are very dynamic and fast response behavior is required.



### Device protection, type 3

The surge protective devices are generally installed immediately upstream of the end devices to be protected. PLT-EE provides optimal protection for single-phase industrial power supplies in various nominal voltage ranges.



### Availability

Surge protection by Phoenix Contact plays a major role in assuring a high level of system availability in the widest range of applications.



### Signal protection for MCR technology

Surge protection for measurement and control technology includes versions that can be used for many fields of application. The benefits of these devices include their proven and cost-optimized functionality as well as their compact and therefore space-saving design with a pitch of just 6 mm.

## Surge protection for the power supply ESSENTIAL edition



From feed-in to the end device, we offer you the right surge protection for a multi-level protection concept. The ESSENTIAL edition product family includes combined type 1+2 surge protective devices, type 2 surge protective devices, and type 3 device protection.

### Type 1+2 combined lightning current and surge arrester



Technical data	
Supply system configuration	1-phase, TN-S / TT (L1, N, PE)
Nominal voltage (V AC)	240 V AC
Maximum continuous operating voltage $U_c$	264 V AC
Nominal discharge current $I_n$ (8/20 $\mu$ s)	12.5 kA
Total discharge current $I_{total}$ (10/350 $\mu$ s)	25 kA
Fault warning	Optical fault indication, remote indication contact

Type	Item No.
SP-EE-FLT-T1-264/12.5-1+1-UT-R	1326690

### Type 1+2 combined lightning current and surge arrester



Technical data	
Supply system configuration	3-phase, TN-C (L1, L2, L3, PEN)
Nominal voltage (V AC)	240/415 V AC
Maximum continuous operating voltage $U_c$	264 V AC
Nominal discharge current $I_n$ (8/20 $\mu$ s)	12.5 kA
Total discharge current $I_{total}$ (10/350 $\mu$ s)	37.5 kA
Fault warning	Optical fault indication, remote indication contact

Type	Item No.
SP-EE-FLT-T1-264/12.5-3+0-UT-R	1326690

### Type 1+2 combined lightning current and surge arrester



Technical data	
Supply system configuration	3-phase, TN-S / TT (L1, L2, L3, N, PE)
Nominal voltage (V AC)	240/415 V AC
Maximum continuous operating voltage $U_c$	264 V AC
Nominal discharge current $I_n$ (8/20 $\mu$ s)	12.5 kA
Total discharge current $I_{total}$ (10/350 $\mu$ s)	50 kA
Fault warning	Optical fault indication, remote indication contact

Type	Item No.
SP-EE-FLT-T1-264/12.5-3+1-UT-R	1326698

Type 2 surge Protection



Technical data	
Supply system configuration	1-phase, TN <sub>DS</sub> / TT (L1, N, PE)
Nominal voltage (V AC)	240 V AC
Maximum continuous operating voltage U <sub>c</sub>	275 V AC
Nominal discharge current I <sub>n</sub> (8/20 μs)	20 kA
Maximum discharge current I <sub>max</sub> (8/20 μs)	40 kA
Fault warning	Optical fault indication, remote indication contact

Type	Item No.
SP-EE-VAL-T2-275-1+1-UT-R	1754877



Technical data	
Supply system configuration	3-phase, TN <sub>DS</sub> / TT (L1, L2, L3, N, PE)
Nominal voltage (V AC)	240/415 V AC
Maximum continuous operating voltage U <sub>c</sub>	275 V AC
Nominal discharge current I <sub>n</sub> (8/20 μs)	20 kA
Maximum discharge current I <sub>max</sub> (8/20 μs)	40 kA
Fault warning	Optical fault indication, remote indication contact

Type	Item No.
SP-EE-VAL-T2-275-3+1-UT-R	1754870



Technical data	
Supply system configuration	1-phase, TN <sub>DS</sub> / TT (L1, N, PE)
Nominal voltage (V AC)	240 V AC
Maximum continuous operating voltage U <sub>c</sub>	335 V AC
Nominal discharge current I <sub>n</sub> (8/20 μs)	20 kA
Maximum discharge current I <sub>max</sub> (8/20 μs)	40 kA
Fault warning	Optical fault indication, remote indication contact

Type	Item No.
SP-EE-VAL-T2-335-1+1-UT-R	1466740



Technical data	
Supply system configuration	3-phase, TN <sub>DS</sub> / TT (L1, L2, L3, N, PE)
Nominal voltage (V AC)	240/415 V AC
Maximum continuous operating voltage U <sub>c</sub>	335 V AC
Nominal discharge current I <sub>n</sub> (8/20 μs)	20 kA
Maximum discharge current I <sub>max</sub> (8/20 μs)	40 kA
Fault warning	Optical fault indication, remote indication contact

Type	Item No.
SP-EE-VAL-T2-335-3+1-UT-R	1466742



Technical data	
Supply system configuration	1-phase, TN <sub>DS</sub> / TT (L1, N, PE)
Nominal voltage (V AC)	240 V AC
Maximum continuous operating voltage U <sub>c</sub>	385 V AC
Nominal discharge current I <sub>n</sub> (8/20 μs)	20 kA
Maximum discharge current I <sub>max</sub> (8/20 μs)	40 kA
Fault warning	Optical fault indication, remote indication contact

Type	Item No.
SP-EE-VAL-T2-385-1+1-UT-R	1466749



Technical data	
Supply system configuration	3-phase, TN $\overline{S}$ / TT (L1, L2, L3, N, PE)
Nominal voltage (V AC)	240/415 V AC
Maximum continuous operating voltage U <sub>c</sub>	385 V AC
Nominal discharge current I <sub>n</sub> (8/20 $\mu$ s)	20 kA
Maximum discharge current I <sub>max</sub> (8/20 $\mu$ s)	40 kA
Fault warning	Optical fault indication, remote indication contact

Type	Item No.
SP-EE-VAL-T2-385-3+1-UT-R	1466755

### Type 3 surge protection device, TN-S, V, Remote indication contact



Technical data	
Supply system configuration	TN-S
Nominal voltage	24 V AC
Fault warning	Optical, remote indicator contact
Nominal discharge current I <sub>n</sub>	1 kA
Combined surge (without reference direction)	2 kV

Type	Item No.
PLT-EE-T3-24DC-R	1249054

### Type 3 surge protection device, TN-S, V, Remote indication contact



Technical data	
Supply system configuration	TN-S
Nominal voltage	60 V AC
Fault warning	Optical, remote indicator contact
Nominal discharge current I <sub>n</sub>	2 kA
Combined surge (without reference direction)	4 kV

Type	Item No.
PLT-EE-T3-60AC-R	1249056

### Type 3 surge protection device, TN-S, TT, V, Remote indication contact



Technical data	
Supply system configuration	TN-S TT
Nominal voltage	120 V AC 120 V AC
Fault warning	Optical, remote indicator contact
Nominal discharge current I <sub>n</sub>	3 kA
Combined surge (without reference direction)	6 kV

Type	Item No.
PLT-EE-T3-120AC-R	1249058

### Type 3 surge protection device, TN-S, TT, V, Remote indication contact



Technical data	
Supply system configuration	TN-S TT
Nominal voltage	240 V AC 240 V AC
Fault warning	Optical, remote indicator contact
Nominal discharge current I <sub>n</sub>	3 kA
Combined surge (without reference direction)	6 kV

Type	Item No.
PLT-EE-T3-230AC-R	1249060

# Terminal blocks

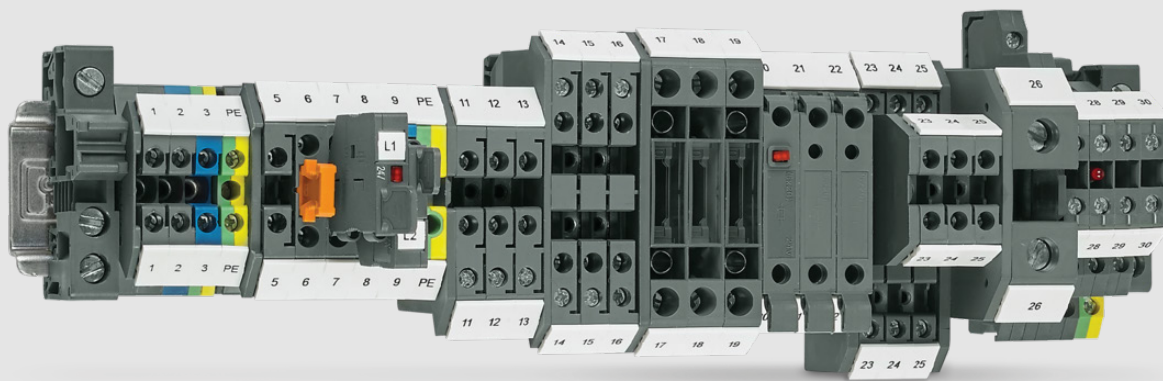

## Terminal blocks

Screw connections are still the dominant method in industrial connection technology. No other connection technology can achieve such high contact forces in the tightest of spaces. With the modular structure and comprehensive range of accessories, tailor-made solutions can be configured for every application.

## Product range overview

Feed-through terminal blocks, multi-conductor terminal blocks, and multi-level terminal blocks	<b>38</b>
Sensor terminal blocks and actuator terminal blocks	<b>50</b>
Fuse terminal blocks, component terminal blocks, and diode terminal blocks	<b>52</b>
Plug-in terminal blocks	<b>54</b>
Disconnect and knife-disconnect terminal blocks	<b>55</b>

**Quality in every application**

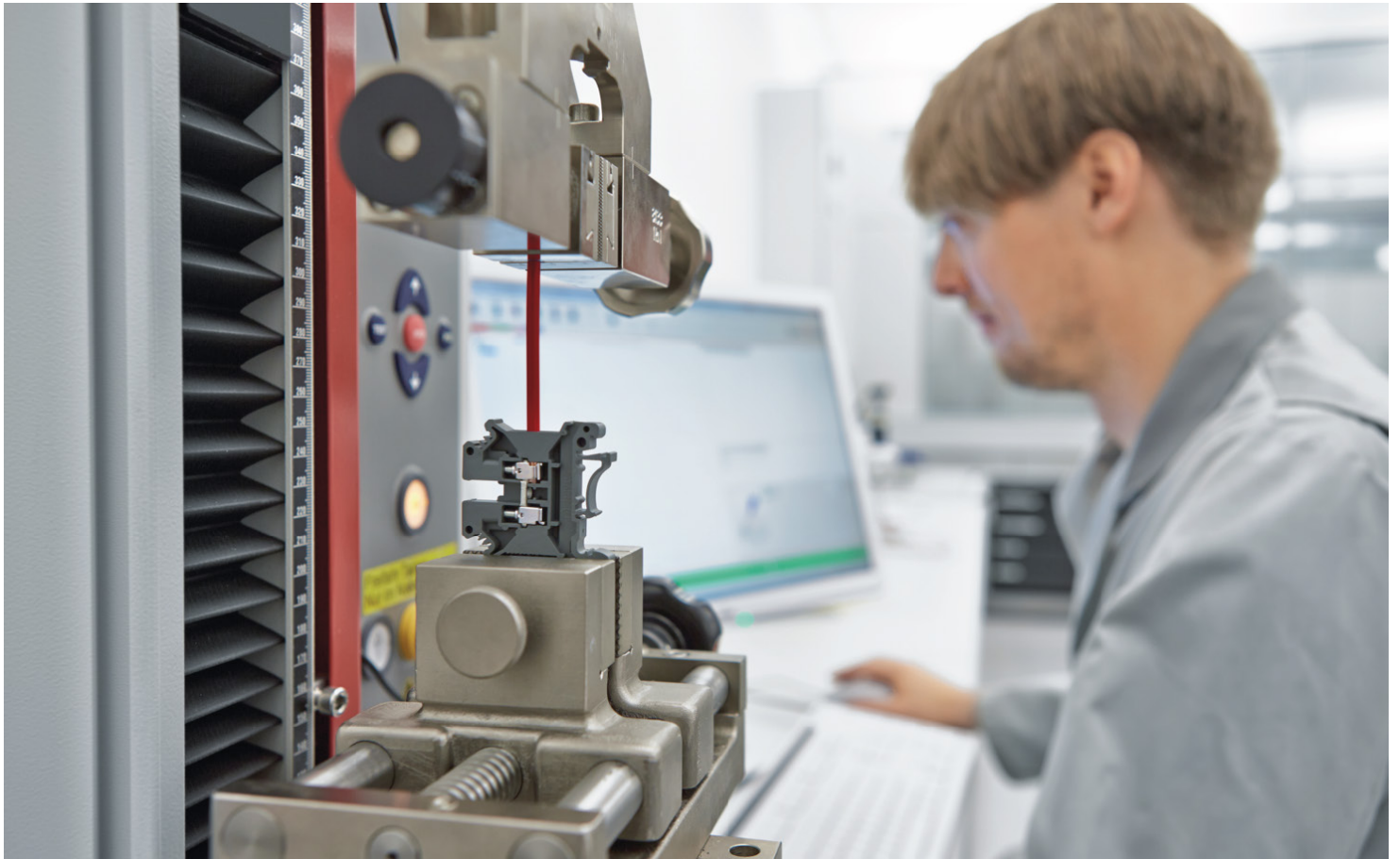

With the comprehensive product range, the terminal blocks are ideal components for applications in a wide range of industrial fields. Numerous quality tests have proven that even under harsh conditions, the TB terminal blocks transmit signals and distribute energy reliably and safely.

### Infrastructure



Measuring devices can be looped in quickly and easily with knife disconnect terminal blocks to check the system during startup and maintenance. The terminal blocks with disconnect zone, which are the same shape, also allow component connectors or fuse plugs to be used to protect the signals.  
Corrosion test:  
DIN 50018

### Power engineering



The TB series is ideal for the energy supply sector with its individual and easily configurable measuring transducer sets for all current transformer and voltage transducer applications.  
Touch protection:  
IEC 60529 /DIN EN 50274

### Wind power



When it comes to the modular structure of wind turbine generators, the TB terminal blocks with connector help prevent wiring errors and save time.  
Vibration test:  
IEC 60068-2-6

### Machine building



The amount of wiring effort and space required when connecting sensors and actuators can be reduced considerably with the TBIO. Temporary high currents, e.g., when starting up electric motors, present no problem for the TB terminal blocks.  
Short-time withstand current:  
IEC 60947-7-1/-2

### Signal technology



Signals can be transmitted safely in a confined space with the compact double-level terminal blocks. Thanks to the use of modern materials, the TB terminal blocks are also ideal for use in challenging environments, such as atmospheres containing salt or at temperatures as low as -60°C.  
Salt spray:  
IEC 60068-2-11/-52

### Photovoltaics



Conductors with a larger cross section are used for the connection between SCBs and inverters due to the higher currents and longer cable lengths. TB terminal blocks can accommodate conductors up to a cross section of 240 mm<sup>2</sup>.  
Conductor pull-out test:  
IEC 60947-7-1/-2

## Quality tests

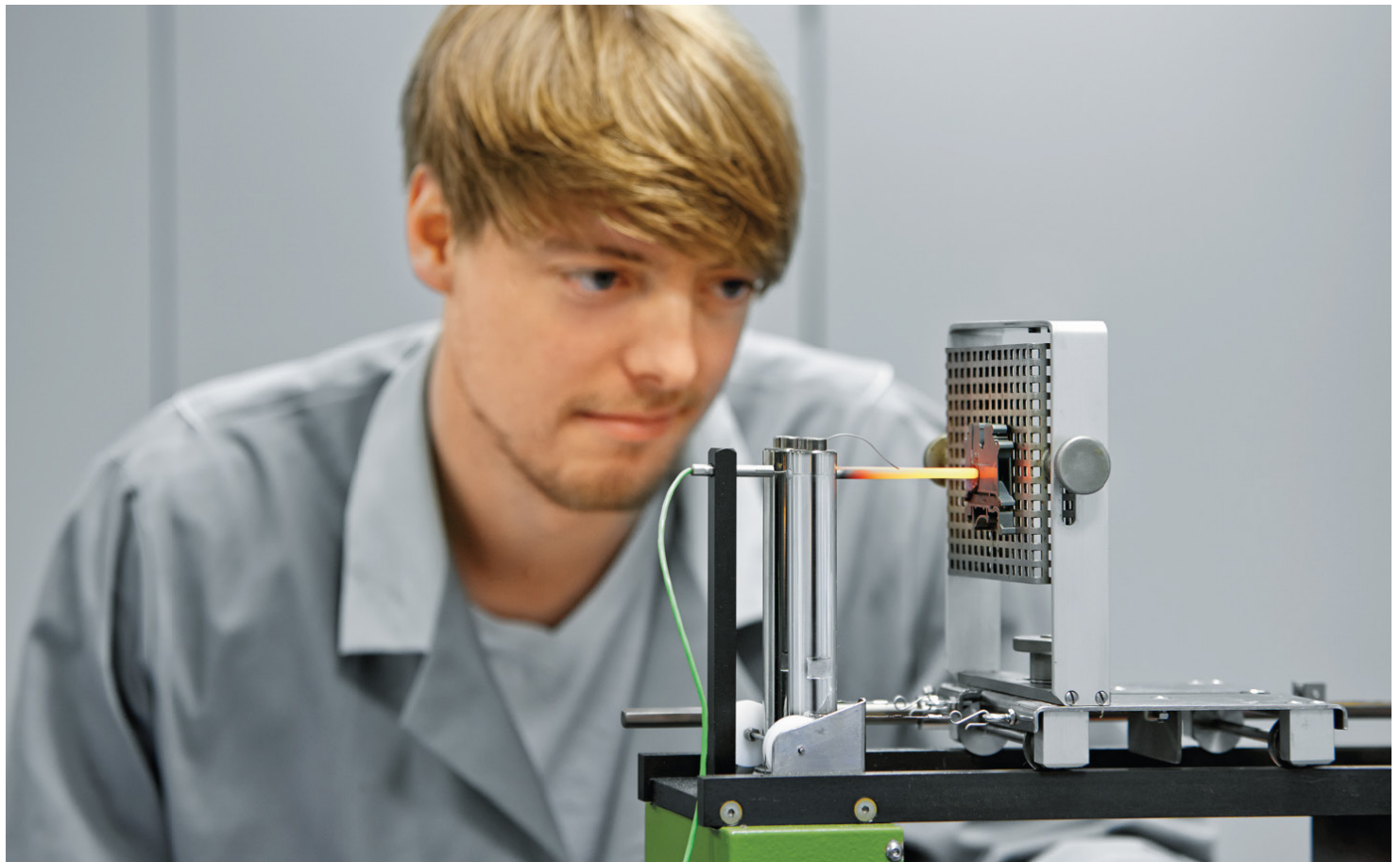

Reliable connections - that is our everyday motto. The quality of our products is the key. This is not tested subsequently on finished products, but is ensured responsibly during every step of production. TB terminal blocks represent compact, high-performance electrical connections. High-quality physical properties and advanced industrial standards are evidenced by connections with long-term stability. This high quality is demonstrated by recognized tests which are documented in national and international standards.

### **Test sequence for terminal blocks in accordance with IEC 60947-7-1/2**

- Connection capacity
- Mechanical strength
- Bending test – flexion test
- Conductor pull-out test
- Modular terminal block fixed securely
- Air clearances and creepage distances
- Impulse withstand voltage test
- Voltage drop test
- Temperature-rise test
- Short-time current resistance
- Dielectric test
- Aging test
- Needle flame test

## Conductor pull-out test

### IEC 60947-7-1/-2

In practice, tensile forces can affect the terminal point during wiring or operation. Correctly wired terminal blocks must therefore offer a high degree of mechanical safety. To test the tensile load capacity of a terminal point, the terminal point must withstand a given tensile force based on the cross section for over 60 seconds. This test is performed after the flexion test.

Performing these two tests directly one after the other intensifies the requirements. The tensile force exerts stress on the conductor at the terminal point. The conductor must be held without causing damage. The TB screw terminal blocks withstand tensile forces up to 100% above the required minimum values.

Conductor cross-section		Tractive force
[mm <sup>2</sup> ]	AWG / kcmil	[N]
0.2	24	10
	...	
4	12	60
	...	
240	500	578

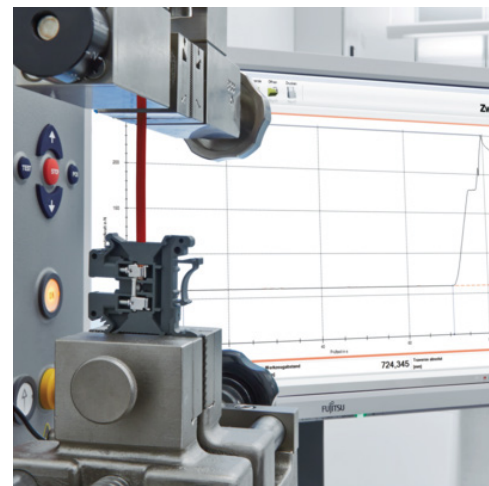

Absorption of tensile force at a 6 mm<sup>2</sup> screw terminal block

## Short-time current resistance

### IEC 60947-7-1/-2

Terminal blocks must, in practice, also be capable of resisting short-circuit currents until the relevant safety equipment cuts off the current without sustaining any damage. This can take up to several tenths of a second.

For testing purposes, a terminal block is mounted on the support and wired to a conductor with the rated cross section. Protective conductor terminal blocks are subjected in three stages of one second each to a current density of 120 A/mm<sup>2</sup> with the rated cross section.

The requirements are met if, after the test, the individual parts are undamaged and they can still be used.

Before and after the test, the terminal block must pass the voltage drop test. The voltage drop before and after the test must not exceed 3.2 mV per terminal block and also must not exceed 1.5 times the value measured before the test.

In the case of the TB 240 I high-current terminal block, a test current of 28,800 A is passed through the terminal block for one second without loss of quality.

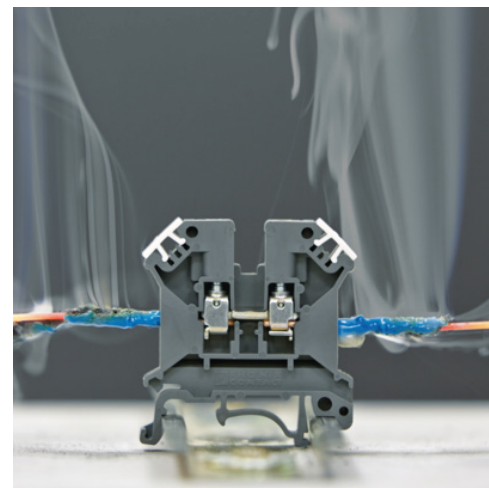

Maximum contact reliability, even under extreme overload.

#### Corrosion test

##### DIN 50018

The key role of the metal parts of electrical connections becomes particularly apparent in aggressive environments. Corrosion-free contact areas are a prerequisite for low-resistance and therefore high-performance connections. This test method describes a corrosion test in condensation climates with an atmosphere that contains sulfur dioxide. Acidic compounds < Ph 7 form during the test and attack the metal surfaces. Two liters of distilled water and one liter of SO<sub>2</sub> gas are introduced into the test chamber. Sulfurous acid forms at a testing temperature of 40°C during the course of the test.

After eight hours of testing, the test objects are left to dry for 16 hours with the door open. At the end of the test, the test objects are visually inspected, and the contact resistance is measured in order to show the influence of this corrosion test on the contact point in more detail. The TB series from Phoenix Contact creates high-quality, gas-tight connections that cannot be impaired even by corrosive substances.

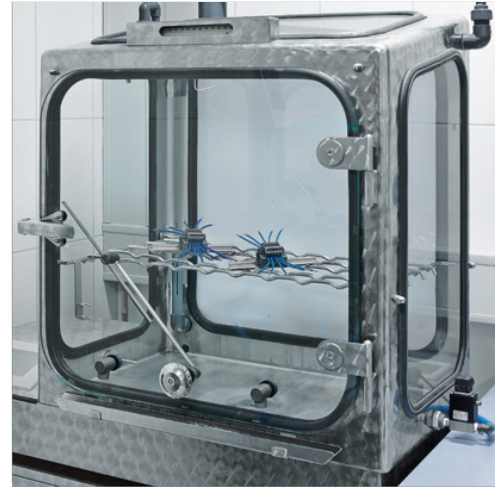

## Aging test IEC

### 60947-7-1/-2

From the point of view of long lifecycles of the terminal blocks, the aging behavior also plays an important role.

In this test, the contact quality is verified by means of simulated aging.

To simulate several years of use, five terminal blocks are mounted horizontally on a rail and connected in series using conductors with the rated cross section. Conductors with a minimum length of 300 mm are connected and the voltage drop is measured at every terminal block. The minimum temperature in the climate cabinet is set to 20°C and the maximum temperature to 85°C. During the heating phase and the 10-minute pause phase with maximum temperature, the rated current flows. As a result, the maximum permissible operating temperature of the test object (max. 130°C) is reached. The cooling down phase follows. The voltage drop is always measured after 24 cycles in the cooled down state (approximately 20°C). The test consists of a total of 192 cycles. The voltage drop must not exceed 3.2 mV initially. During or after testing, it must not exceed 4.8 mV or 1.5 times the value measured after the 24th cycle.

TB terminal blocks are designed for extreme durability even under difficult temperature conditions. Plastic as well as metal parts provide sufficient safety reserves.

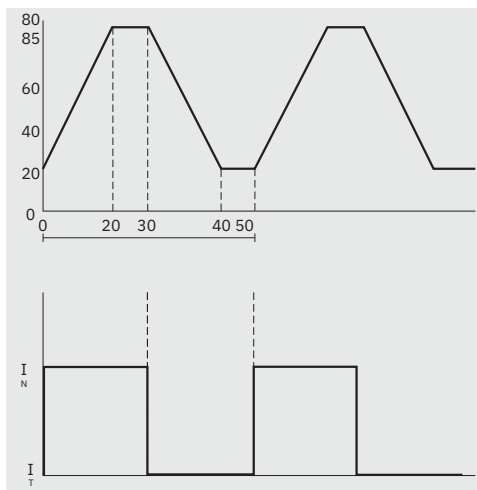

Current and temperature in relation to time  $t_T$



#### Salt spray

#### IEC 60068-2-11/-52

Particularly in shipbuilding, technical components have to function continuously in corrosive atmospheres. The salt content of the air combined with the increased humidity places high demands on the metal parts used. The impact of the climate at sea can be simulated on the basis of the above standard.

The resistance of the materials is tested with salt spray in a corrosive atmosphere. The test objects are placed in the test chamber and subjected to a finely dosed spray of 5% sodium chloride solution (NaCl; pH value 6.5 - 7.2) at a temperature of 35°C for a period of 96 hours.

At the end of the test, the test objects are visually inspected and an electrical test is performed to show the influence of this corrosion test on the contact point in more detail.

The TB terminal blocks create a gas-tight connection to the connected conductors. This means that the contact point is protected against corrosion even under extreme climatic conditions.

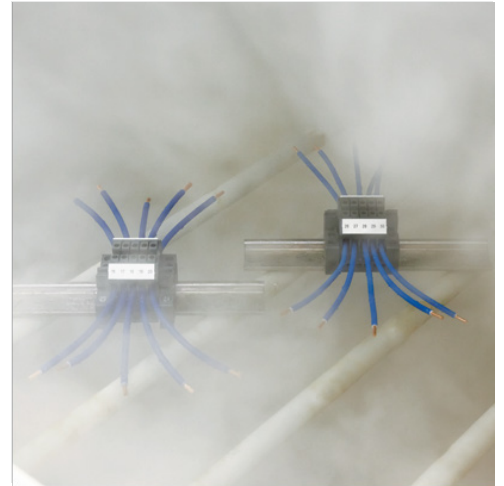

## Voltage drop test IEC

### 60947-7-1/-2

In every terminal point of a terminal block, one or more conductors are connected - depending on the connection technology. Current transfer is strongly affected by the electrical resistance between the conductor and the current bar. High-quality contacts create a gas-tight connection. This is the only way to ensure a permanently reliable connection. This electrical test therefore determines the voltage drop on a terminal block (two terminal points). Conclusions regarding the contact resistance and the contact quality can therefore be made.

The terminal blocks are wired with the rated cross section. For measuring purposes, the terminal blocks are charged with a direct test current corresponding to 0.1 times the current carrying capacity of the rated cross section. The voltage drop is measured at a distance  $\leq 10$  mm from the center of the terminal point (see diagram).

At a room temperature of  $\sim 20^{\circ}\text{C}$ , the voltage drop must not exceed 3.2 mV per terminal block before or after the test, nor must it exceed 1.5 times the value measured at the start of the test.

TB terminal blocks are up to 60% below the limit values required by standards.

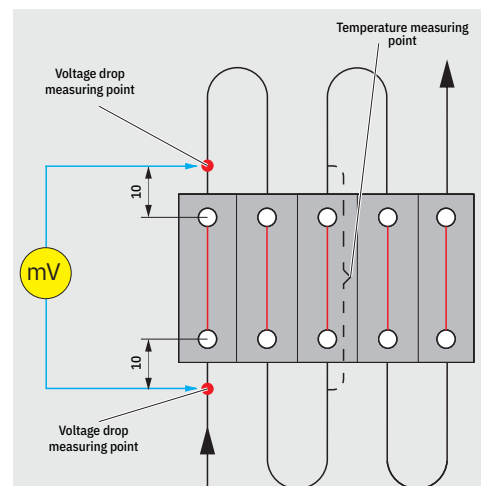

Rated cross section [mm <sup>2</sup> ]	Current carrying capacity [A]	Rated cross section AWG	Current carrying capacity [A]
0.2	4	24	4
0.5	6	20	8
0.75	9	18	10
1	13.5		
1.5	17.5	16	16
2.5	24	14	22
4	32	12	29
6	41	10	38
10	57	8	50
16	76	6	67
35	125	2	121
50	150	0	162
95	232	0000	217
150	309	00000	309
240	415	500 MCM	415

#### Needle flame test IEC

##### 60947-7-1/-2

As far as the use of terminal blocks is concerned, behavior in fire when in direct contact with a source of ignition is a major criterion. Such sources of ignition could be electric arcs along a creepage distance, for example. Terminal blocks must not aid or accelerate fires and the plastics must have self-extinguishing properties.

This fire test simulates the behavior of the components with an external source of ignition acting on them directly from outside. In the test, a naked flame fed with butane gas is held at an edge or surface of the test object at an angle of 45° for 10 seconds (see figure). The behavior of the test object without a source of ignition is then observed.

The test is deemed to be passed when the flames or glowing processes are extinguished within 30 seconds of the flame being removed and when the tracing paper beneath the test object is not ignited by falling drops of burning substances. All TB terminal blocks pass the needle flame test, thanks to the high-grade plastics used and their structural design.

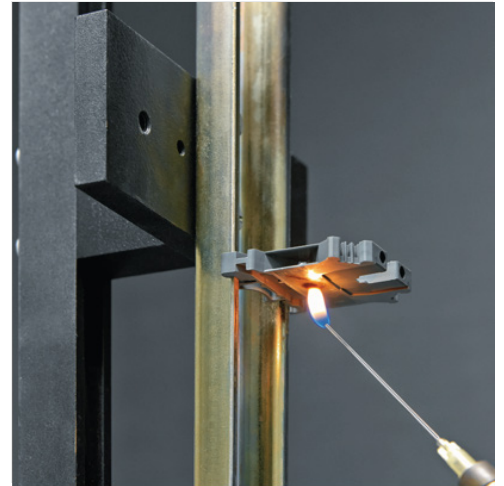

#### Glow-wire test

##### IEC 60695-2-11

In the event of overload, conductive metal parts of the terminal block or connected conductors can heat up considerably. This additional heat affects the plastic housing. To simulate this source of danger for electrotechnical components, a glow wire is heated to a specific temperature (550°C, 650°C, 750°C, 850°C or 960°C) in a glow wire test and is then pushed onto the thinnest part of the housing of the test object at a right angle with a force of 1 N, as shown in the figure. The test is deemed to be passed:

- When the tracing paper beneath the glow wire does not ignite due to any drops of burning substances falling down. The polyamides used for the TB terminal blocks as housing materials all meet the requirements of the glow-wire test at 960°C (highest level).

- When no flame or glowing process occurs during the test
- When the flames or glowing processes are extinguished within 30 seconds of the glow wire being removed

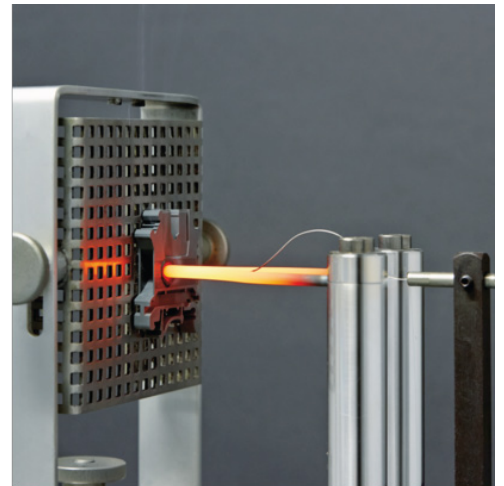

## Inflammability classification

### UL 94

UL 94 describes inflammability tests that have gained particular importance in the field of electrical engineering. Behavior in fire is the main focus. Items are classified in accordance with either UL 94 HB (Horizontal Burn) or UL 94 V (Vertical Burn). The test setup is such that the 94 V0/1/2 classifications are stricter than the 94 HB classification.

### UL 94 V0/1/2

After conditioning, the test bar is vertically clamped and flame-treated

times for 10 seconds at a time. Between the flame treatments, the time until the test bar is extinguished is measured. Afterwards, the afterburning times and the drip behavior are evaluated. The plastic used for TB terminal blocks meets the higher-grade criteria for classification as a V0 material.

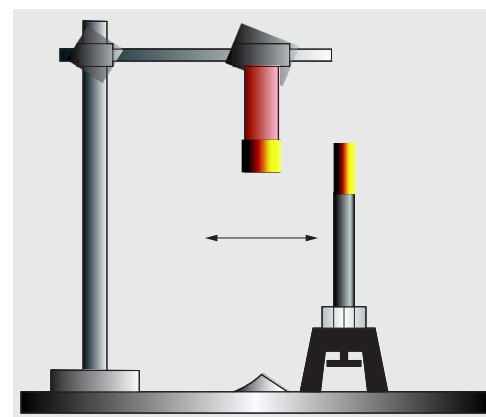

Classification	UL 94 V0	UL 94 V1	UL 94 V2
Burning time after each flame treatment	≤ 10 s	≤ 30 s	≤ 30 s
Total burning time after 10 flame treatments	≤ 50 s	≤ 250 s	≤ 250 s
Glowing time after the 2nd flame treatment	≤ 30 s	≤ 60 s	≤ 60 s
Complete burn-off	no	no	no
Ignition of the absorbent cotton under the sample	no	no	no

## Behavior in fire

### NF F 16-101

NF F 16-101 describes the behavior in fire of plastics on the basis of two indices (I and F). As such, the following tests are performed: glow-wire test, oxygen index, smoke gas opacity, smoke gas toxicology.

1. Determination of index I (0 - 4) Index I is determined from the results of the glow-wire test and the oxygen index, using the following table. Here, I 0 is the best classification and I 4 the worst.

Index	Oxygen index	Glow wire
I 0	70 %	960°C, no flame formation
I 1	45 %	960°C, no flame formation
I 2	32 %	960°C, no flame formation
I 3	28 %	850°C, no flame formation
I 4	20 %	850°C, flame extinguishes quickly

2. Determination of smoke index F (0 - 5) This is based on the smoke gas opacity and the smoke gas toxicity. The following concentrations in [ppm] are considered critical:

Carbon monoxide (CO)	1750
Carbon dioxide (CO <sub>2</sub> )	90000
Hydrochloric acid (HCl)	150
Hydrobromic acid (HBr)	170
Hydrocyanic acid (HCN)	55
Hydrofluoric acid (HF)	17

Using the test results, a smoke index is documented and can be assigned to classes F 0 – F 5 depending on the value. Here, F 0 is the best classification and F 5 the worst. The TB terminal blocks attain classification I 2/F 2.

#### Smoke gas toxicity

##### SMP 800-C

SMP 800-C describes the maximum permissible values of toxic smoke gases when a plastic is burned. In comparison to the BSS 7239 (Boeing standard), this standard specifies more precise measuring methods for the qualitative and quantitative determination of toxic smoke gases that result when a test object is completely burned. The smoke gases of these measurements are taken from the NBS test chamber of the ASTM E 662 test. The same time scheme is valid here as in ASTM E 662. This fire test simulates the behavior of the components with an external source of ignition acting on them directly from outside. Data is recorded over a full 20 minutes.

SMP 800-C limit values of toxic smoke gases in ppm:

Carbon monoxide (CO)	3500
Carbon dioxide (CO <sub>2</sub> )	90000
Nitrogen oxides (NO <sub>x</sub> )	100
Sulfur dioxide (SO <sub>2</sub> )	100
Hydrochloric acid (HCl)	500
Hydrobromic acid (HBr)	100
Hydrofluoric acid (HF)	100

The polyamides used for the TB series are many times below the critical concentrations.

#### Surface inflammability

##### ASTM E 162

The spread of a fire under the influence of heat is tested and evaluated in the above standard.

To evaluate the surface inflammability of plastics, a “flame spread index” is devised in accordance with ASTM E 162 to provide information on flame propagation under given test conditions.

For this purpose, a sample (152 x 457 x maximum 25.4 mm) is irradiated with a heat source (815°C) at an angle of 30° and ignited with a naked flame at the top end. During the 15-minute duration of the test, the time in which the flame front reaches two measuring points that are 76 mm apart is determined. The product of this flame propagation time and a calculated heat development factor yields the “flame spread index”.

In the American railroad sector, the maximum limit value is 35. In this test, the drip behavior of the plastic is also observed and evaluated.

The TB terminal blocks from Phoenix Contact achieve a flame spread index of 5, drip without burning, and are therefore well below the maximum permitted values of the Federal Railroad Administration (FRA) of the US Department of Transportation.

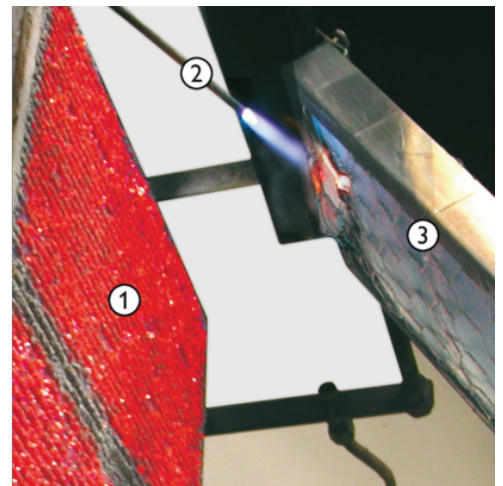

- ① Radiant heater
- ② Flame
- ③ Plastic sample

## Vibration test IEC

### 60068-2-6

This test demonstrates the vibration resistance of a terminal connection subjected to permanent vibrations. Harmonic, sinusoidal vibrations are applied to the test object to simulate rotating, pulsating or oscillating forces. The test is performed on each of the three spatial axes (X, Y, Z). In the test, the objects run through a frequency range of 5 Hz to 150 Hz at a speed of one octave per minute. The r.m.s. value of the acceleration is up to 40 m/s<sup>2</sup>. The test objects are tested for two hours on each of the three axes (x, y, z). No damage may occur to the terminal blocks that would impair their further use. In addition, no contact interruptions of > 1 µs are permitted during the test. The contact resistance is measured before and after the test.

TB terminal blocks meet the requirements of the standard without the electrical contact being interrupted. They are therefore particularly suitable for challenging applications in which the reliable function of the terminal connection must be ensured, even when subjected to vibrations.

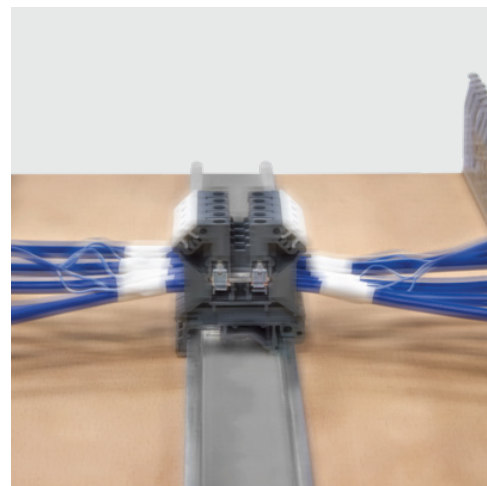

## Touch proofness

### IEC 60529 / DIN EN 50274

Electrical installations and plants must also afford service technicians a high level of safety when carrying out maintenance involving measuring and testing tasks. BGV A2 specifies safety distances for work, operation, and occasional handling near parts that pose a potential danger in low-voltage plants up to 1000 V AC and 1500 V DC, based on standard IEC 60529. For the purpose of contact safety, a distinction is made between back-of-hand safety and finger safety (touch proofness). The extent to which conductive parts are safe to touch is tested with a test finger and test ball. It must not be possible to touch conductive parts with the test equipment. TB terminal blocks offer finger and contact safety.

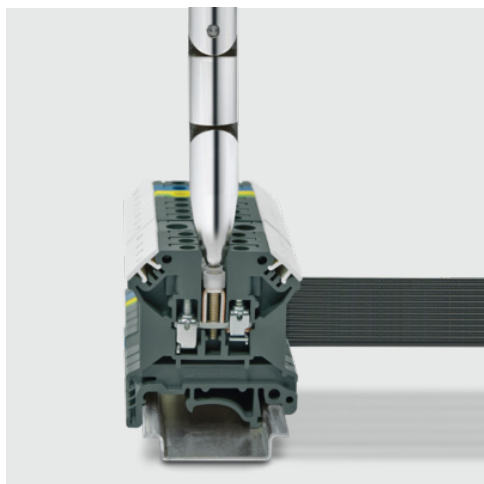

Test finger Ø 12,5 mm



Test ball Ø 50 mm

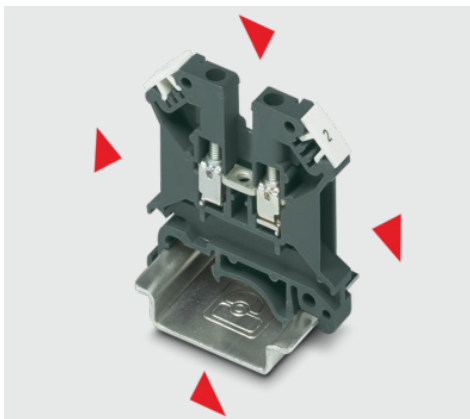
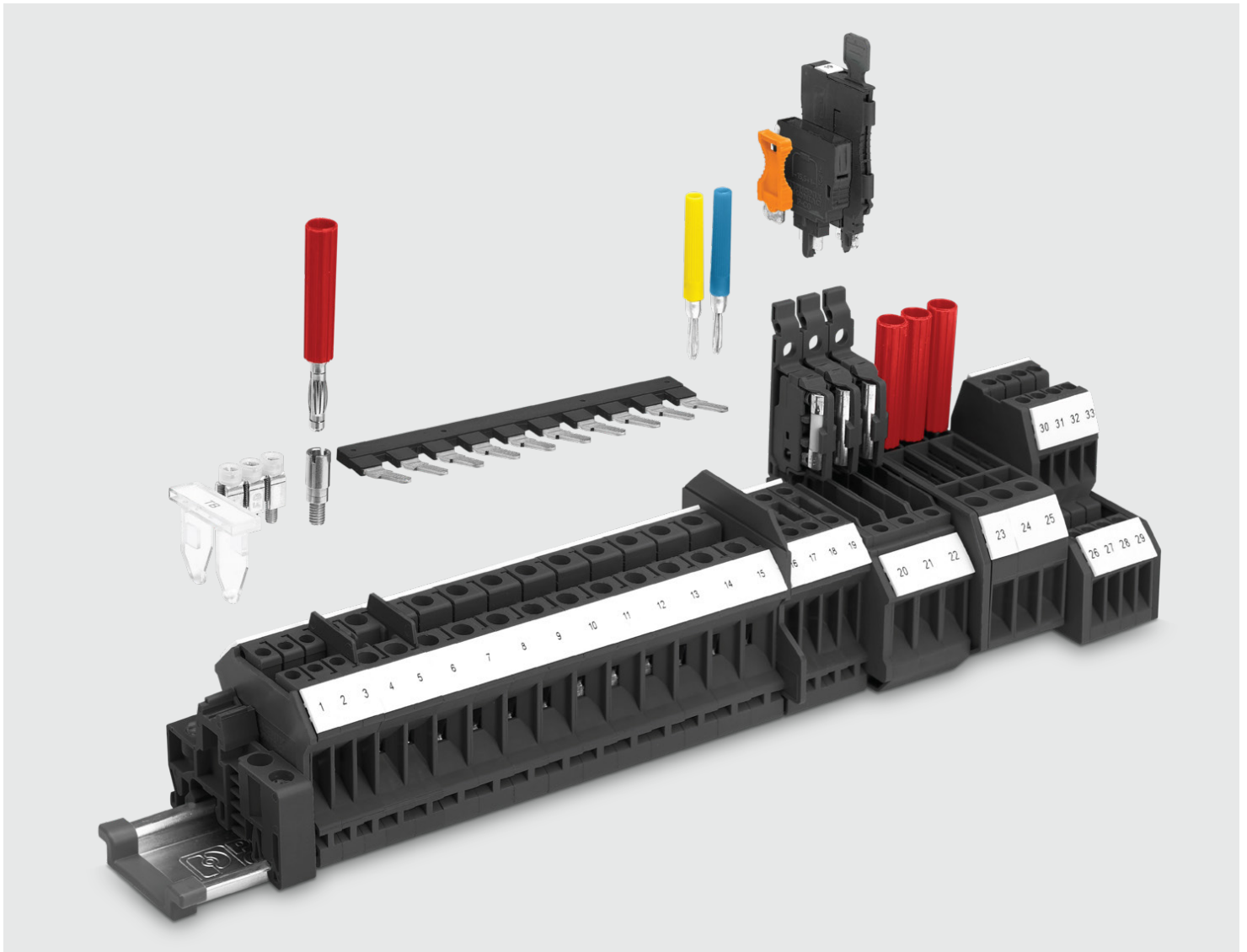

### Compact design

Thanks to the space-saving design, the TB modular terminal blocks are ideal for control systems where limited space is available.

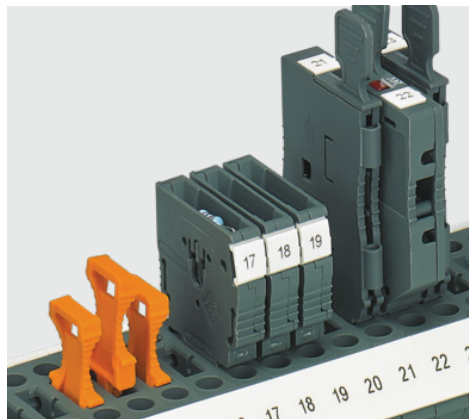

### Function zone

The P-DI isolating plug, the CP ... component connector, and the FP ... cartridge fuse plugs can be used in the universal plug-in zone of the disconnect terminal block.

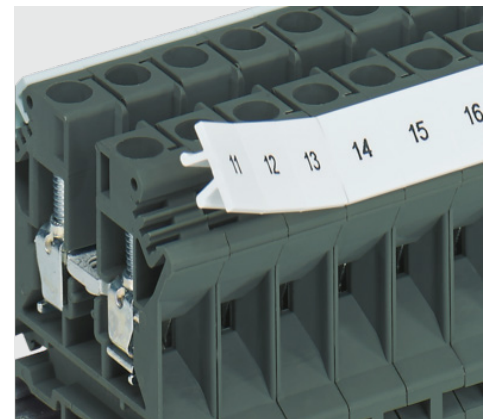

### Large-surface labeling

Large-surface and clear marking of the terminal points is essential for reliable and quick installation. Each terminal point in the TB series can be marked separately.

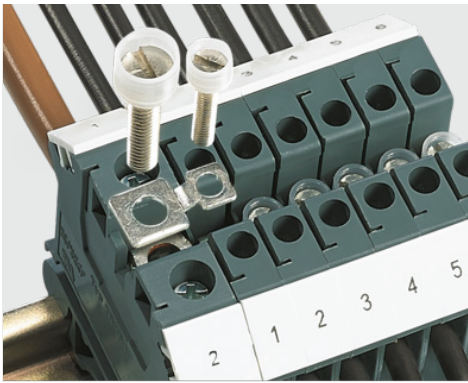

If used with the corresponding fixed bridges, the RB TB... reducing bridges allow terminal blocks with different nominal cross sections to be connected. This means that power blocks can be easily created.

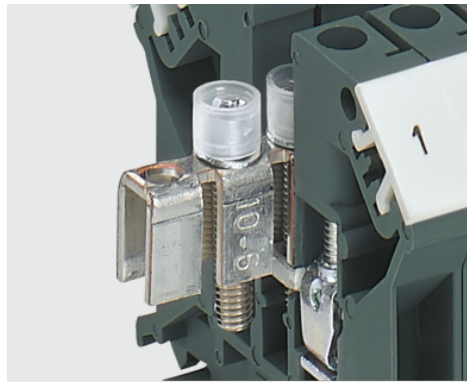

Any number of positions can be easily disconnected from the 10-pos. strip of the SCBI ... fixed bridge with insulating cap, placed in the bridge shaft, and screwed tight.

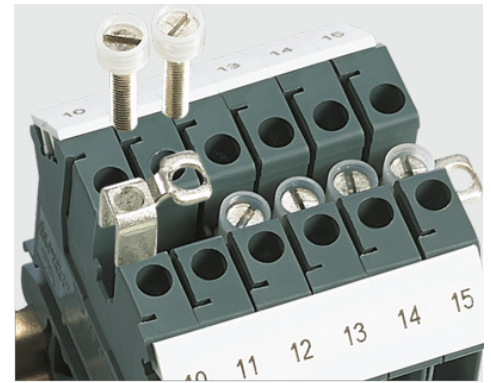

Any number of terminal blocks can be easily bridged according to the application using the MSCB ... modular chain bridges.

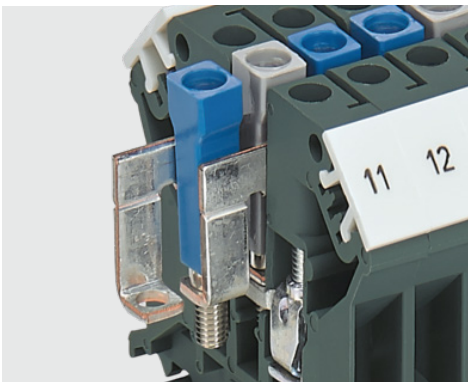

The L bridges can be used to route two different potentials in the bridge shaft. Insulated and color-coded contact screws clearly indicate the relevant potential.

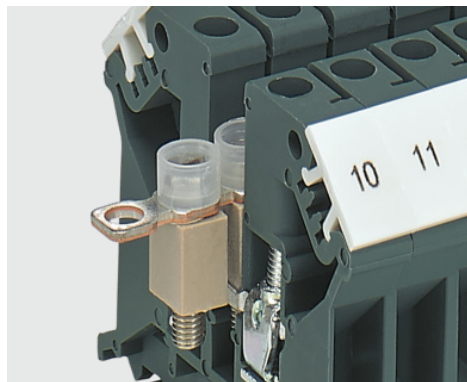

The SCBI ...ISO isolator bridge bars support switchable cross connections. Here the screw has the function of a live contact.

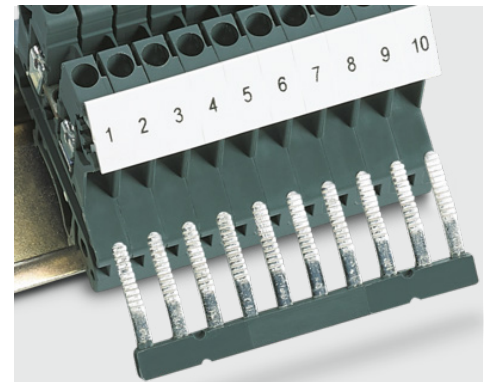

The INB ... isolated insertion bridges are simply clamped down at the connection points, with or without conductors. The bridges can be assembled as required for the number of positions. Individual forks are removed for bridging between non-adjacent terminal blocks.

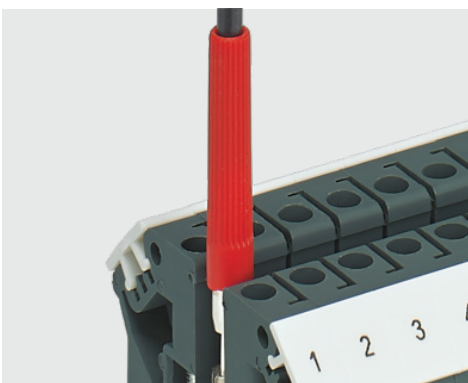

PSB ... test sockets which can be screwed into the bridge shaft enable reliable test pick-off for 2.3 mm and 4 mm test plugs. The 2.3 mm MPS ... test plug makes direct contact in the bridge shaft when using terminal blocks with an overall width of 5.2 mm and 6.2 mm.



The TS-TB insulation plate is used to electrically isolate and visually separate two neighboring bridges. An insulation plate should be placed on both sides of the bridge in order for the terminal blocks to retain their complete nominal voltage.

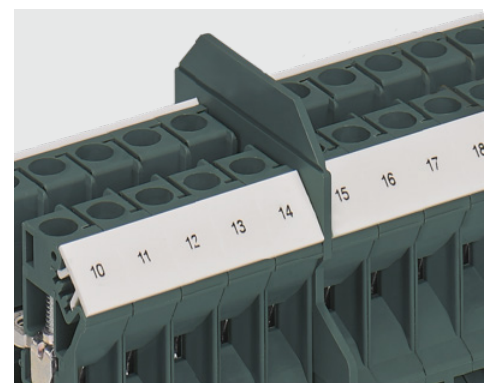

The partition plates protrude beyond the terminal block contours. They provide visual as well as electrical group separation.

**Feed-through terminal blocks, multi-conductor terminal blocks, and multi-level terminal blocks**

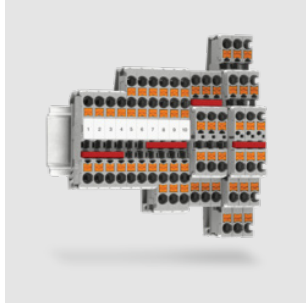

Use the feed-through terminal blocks, multi-level terminal blocks, and multi-conductor terminal blocks from Phoenix Contact for space-saving connection of two or more conductors in just one terminal block. The terminal blocks are characterized by their flexible bridgeability and optimum marking options.

**ESSENTIAL edition | Feed-through terminal block, Screw connection, 2,5 mm<sup>2</sup>, 24 A, width 5,2 mm**



Common technical data	
Approvals	
Connection method	Screw connection
Connection cross-section	2.5 mm <sup>2</sup>
Width	5.2 mm
Number of connections	2
Number of rows	1
Conductor cross-section, rigid	0.5 mm <sup>2</sup> ... 4 mm <sup>2</sup>
Conductor cross-section, flexible	0.5 mm <sup>2</sup> ... 2.5 mm <sup>2</sup>
Conductor cross-section, AWG	20 ... 12
Mounting type	NS 35/7,5 NS 35/15 NS 32

Nominal current	Nominal voltage	Color	Protective conductor foot	Number of potentials	Type	Item No.
24 A	800 V	traffic grey B (RAL 7043)	No	1	TB 2,5 I	3246311
24 A	800 V	blue (RAL 5015) green-yellow	No Yes	1	TB 2,5 I BU TB 2,5-PE I	3057665 3059841

Accessories	Type	Item No.
Cover, 1,5 mm, dark gray	D-TB 2,5	3059919
Screw bridge, 10-position, silver-colored, with insulating collar	SCBI 10-5 N	3246117
Insertion bridge, 10-position, gray, Bridging in the terminal point	INB 10-5	3246175
Insulation plate, width 0,5 mm, for electrical isolation of neighboring bridges in the terminal center	TS-TB-2L	3062841
Partition plate, 3 mm, dark gray	ATP-TB	3046272

**ESSENTIAL edition | Multi-level terminal block, Screw connection, 2,5 mm<sup>2</sup>, 21 A, width 5,2 mm**

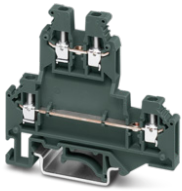

Common technical data	
Approvals	
Connection method	Screw connection
Connection cross-section	2.5 mm <sup>2</sup>
Width	5.2 mm
Number of connections	4
Number of rows	2
Nominal current	21 A
Nominal voltage	500 V
Conductor cross-section, rigid	0.5 mm <sup>2</sup> ... 4 mm <sup>2</sup>
Conductor cross-section, flexible	0.5 mm <sup>2</sup> ... 2.5 mm <sup>2</sup>
Conductor cross-section, AWG	20 ... 12
Protective conductor foot	No
Mounting type	NS 35/7,5 NS 35/15 NS 32
Number of potentials	2

Color	Type	Item No.
traffic grey B (RAL 7043)	TB 2,5-2L I	3246528
blue (RAL 5015)	TB 2,5-2L I BU	3000954

Accessories	Type	Item No.
Cover, 2,5 mm, dark gray	D-TB 2,5/4-2L	3059964
Screw bridge, 10-position, silver-colored, with spring washer and insulating collar	SCBI 10-5 N W	3000833
Insertion bridge, 10-position, gray, Bridging in the terminal point	INB 10-5	3246175
Insulation plate, width 0,5 mm, for electrical isolation of neighboring bridges in the terminal center	TS-TB-2L	3062841
Spacer plate, 2,5 mm, dark gray, compensates for the offset at the lower level when standard terminal blocks are mounted side-by-side	DP-TB-2L	3059977

ESSENTIAL edition | Multi-level terminal block, Screw connection, 2,5 mm<sup>2</sup>, 20 A, width 6,2 mm

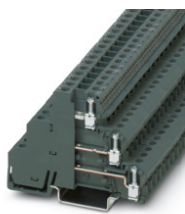

Technical data	
Approvals	UL ENEC
Connection method	Screw connection
Connection cross-section	2.5 mm <sup>2</sup>
Width	6.2 mm
Number of connections	3
Number of rows	3
Nominal current	20 A
Nominal voltage	250 V
Color	traffic grey B (RAL 7043)
Conductor cross-section, rigid	0.2 mm <sup>2</sup> ... 4 mm <sup>2</sup>
Conductor cross-section, flexible	0.2 mm <sup>2</sup> ... 2.5 mm <sup>2</sup>
Conductor cross-section, AWG	24 ... 12
Protective conductor foot	No
Mounting type	NS 35/7,5 NS 35/15

Type	Item No.
TB 2,5-3L I	3246784

Accessories	Type	Item No.
Screw bridge, 10-position, silver-colored, with spring washer and insulating collar	SCBI 10-6 W	3000834
Insertion bridge, 80-position, blue, Bridging in the terminal point, latching in the terminal housing	INB IO 80-6 BU	3246931
Insertion bridge, 80-position, red, Bridging in the terminal point, latching in the terminal housing	INB IO 80-6 RD	3246938
Partition plate, 2 mm, dark gray	ATP-TB/3	3246959

ESSENTIAL edition | Multi-level terminal block, Screw connection, 2,5 mm<sup>2</sup>, 21 A, width 5,2 mm



Common technical data	
Approvals	UL ENEC
Connection method	Screw connection
Connection cross-section	2.5 mm <sup>2</sup>
Width	5.2 mm
Number of connections	4
Number of rows	2
Nominal current	21 A
Nominal voltage	500 V
Conductor cross-section, rigid	0.5 mm <sup>2</sup> ... 4 mm <sup>2</sup>
Conductor cross-section, flexible	0.5 mm <sup>2</sup> ... 2.5 mm <sup>2</sup>
Conductor cross-section, AWG	20 ... 12
Protective conductor foot	No
Mounting type	NS 35/7,5 NS 35/15 NS 32

Color	Type	Item No.
traffic grey B (RAL 7043)	TB 2,5-L/LB I	3000904
blue (RAL 5015)	TB 2,5-L/LB I BU	3000960

Accessories	Type	Item No.
Cover, 2,5 mm, dark gray	D-TB 2,5/4-L/LB	3000906
Screw bridge, 10-position, silver-colored, with spring washer and insulating collar	SCBI 10-5 N W	3000833
Insertion bridge, 10-position, gray, Bridging in the terminal point	INB 10-5	3246175
Insulation plate, width 0,5 mm, for electrical isolation of neighboring bridges in the terminal center	TS-TB-2L	3062841

**ESSENTIAL edition | Multi-level terminal block, Screw connection, 2,5 mm<sup>2</sup>, 21 A, width 5,2 mm**



Technical data	
Approvals	UL, IEC
Connection method	Screw connection
Connection cross-section	2.5 mm <sup>2</sup>
Width	5.2 mm
Number of connections	4
Number of rows	2
Nominal current	21 A
Nominal voltage	500 V
Color	traffic grey B (RAL 7043)
Conductor cross-section, rigid	0.5 mm <sup>2</sup> ... 4 mm <sup>2</sup>
Conductor cross-section, flexible	0.5 mm <sup>2</sup> ... 2.5 mm <sup>2</sup>
Conductor cross-section, AWG	20 ... 12
Protective conductor foot	No
Mounting type	NS 35/7,5 NS 35/15 NS 32

Type	Item No.
TB 2,5-L/LB-PV I	3000901

Accessories	Type	Item No.
Cover, 2,5 mm, dark gray	D-TB 2,5/4-L/LB	3000906
Screw bridge, 10-position, silver-colored, with spring washer and insulating collar	SCBI 10-5 N W	3000833
Insertion bridge, 10-position, gray, Bridging in the terminal point	INB 10-5	3246175
Insulation plate, width 0,5 mm, for electrical isolation of neighboring bridges in the terminal center	TS-TB-2L	3062841

**ESSENTIAL edition | Motor connection terminal block, Screw connection, 2,5 mm<sup>2</sup>, 19 A, width 6,2 mm**

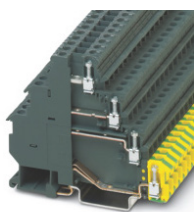

Technical data	
Approval	EAC cULus Recognized
Connection method	Screw connection
Connection cross-section	2.5 mm <sup>2</sup>
Width	6.2 mm
Number of connections	3
Number of rows	3
Nominal current	19 A (with a 2.5 mm <sup>2</sup> conductor cross-section)
Nominal voltage	400 V
Color	traffic grey B (RAL 7043)
Conductor cross-section, rigid	0.2 mm <sup>2</sup> ... 4 mm <sup>2</sup>
Conductor cross-section, flexible	0.2 mm <sup>2</sup> ... 2.5 mm <sup>2</sup>
Conductor cross-section, AWG	24 ... 14
Mounting type	NS 35/7,5 NS 35/15

Type	Item No.
TB 2,5-PE/3L I	3246826

Accessories	Type	Item No.
Screw bridge, 10-position, silver-colored, with spring washer and insulating collar	SCBI 10-6 W	3000834
Insertion bridge, 80-position, blue, Bridging in the terminal point, latching in the terminal housing	INB IO 80-6 BU	3246931
Insertion bridge, 80-position, red, Bridging in the terminal point, latching in the terminal housing	INB IO 80-6 RD	3246938
Partition plate, 2 mm, dark gray	ATP-TB/3	3246959

ESSENTIAL edition | Multi-conductor terminal block, Screw connection, 2,5 mm<sup>2</sup>, 24 A, width 5,2 mm



Technical data	
Approvals	UL, IEC
Connection method	Screw connection
Connection cross-section	2.5 mm <sup>2</sup>
Width	5.2 mm
Number of connections	4
Number of rows	1
Nominal current	24 A
Nominal voltage	500 V
Color	traffic grey B (RAL 7043)
Conductor cross-section, rigid	0.5 mm <sup>2</sup> ... 4 mm <sup>2</sup>
Conductor cross-section, flexible	0.5 mm <sup>2</sup> ... 2.5 mm <sup>2</sup>
Conductor cross-section, AWG	20 ... 12
Protective conductor foot	No
Mounting type	NS 35/7,5 NS 35/15 NS 32
Number of potentials	1

Type	Item No.
TB 2,5-QUATTRO I	3246492

Accessories	Type	Item No.
Cover, 1,5 mm, dark gray	D-TB 2,5/4-QUATTRO	3059838
Screw bridge, 10-position, silver-colored, with spring washer and insulating collar	SCBI 10-5 N W	3000833
Insertion bridge, 10-position, gray, Bridging in the terminal point	INB 10-5	3246175
Insulation plate, width 0,5 mm, for electrical isolation of neighboring bridges in the terminal center	TS-TB-2L	3062841

ESSENTIAL edition | Multi-conductor terminal block, Screw connection, 2,5 mm<sup>2</sup>, 24 A, width 5,2 mm



Common technical data	
Approvals	UL, IEC
Connection method	Screw connection
Connection cross-section	2.5 mm <sup>2</sup>
Width	5.2 mm
Number of connections	3
Number of rows	1
Nominal current	24 A
Nominal voltage	400 V
Conductor cross-section, rigid	0.5 mm <sup>2</sup> ... 2.5 mm <sup>2</sup>
Conductor cross-section, flexible	0.5 mm <sup>2</sup> ... 2.5 mm <sup>2</sup>
Conductor cross-section, AWG	20 ... 14
Protective conductor foot	No
Mounting type	NS 35/7,5 NS 35/15 NS 32
Number of potentials	1

Color	Type	Item No.
traffic grey B (RAL 7043)	TB 2,5-TWIN I	3246489
blue (RAL 5015)	TB 2,5-TWIN I BU	3000950

Accessories	Type	Item No.
Cover, 2 mm, dark gray	D-TB 2,5/4-TWIN	3059825
Screw bridge, 10-position, silver-colored, with spring washer and insulating collar	SCBI 10-5 N W	3000833
Insertion bridge, 10-position, gray, Bridging in the terminal point	INB 10-5	3246175
Insulation plate, for electrical isolation of neighboring bridges in the terminal center	TS-TB	3062838

**ESSENTIAL edition | Feed-through terminal block, Screw connection, 2,5 mm<sup>2</sup>, 24 A, width 5,2 mm**



Common technical data	
Connection method	Screw connection
Connection cross-section	2.5 mm <sup>2</sup>
Width	5.2 mm
Number of connections	2
Number of rows	1
Conductor cross-section, rigid	0.5 mm <sup>2</sup> ... 4 mm <sup>2</sup>
Conductor cross-section, flexible	0.5 mm <sup>2</sup> ... 2.5 mm <sup>2</sup>
Conductor cross-section, AWG	20 ... 12
Mounting type	NS 35/7,5 NS 35/15 NS 32

Approvals	Nominal current	Nominal voltage	Color	Protective conductor foot	Number of potentials	Type	Item No.
	24 A	800 V	traffic grey B (RAL 7043)	No	1	TB 3 I	3059786
	24 A	800 V	blue (RAL 5015)	No	1	TB 3 I BU	3057733
			green-yellow	Yes		TB 3-PE I	3059867

Accessories	Type	Item No.
Cover, 1,8 mm, dark gray	D-TB 4/10	3059809
Screw bridge, 10-position, silver-colored, with spring washer and insulating collar	SCBI 10-5 N W	3000833
Insertion bridge, 10-position, gray, Bridging in the terminal point	INB 10-5	3246175
Insulation plate, for electrical isolation of neighboring bridges in the terminal center	TS-TB	3062838

**ESSENTIAL edition | Protective conductor terminal block, Screw connection, 2,5 mm<sup>2</sup>, width 5,2 mm**

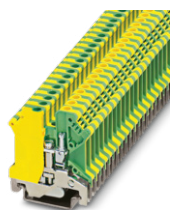

Technical data	
Approvals	
Connection method	Screw connection
Connection cross-section	2.5 mm <sup>2</sup>
Width	5.2 mm
Number of connections	2
Number of rows	1
Color	green-yellow
Conductor cross-section, rigid	0.5 mm <sup>2</sup> ... 4 mm <sup>2</sup>
Conductor cross-section, flexible	0.5 mm <sup>2</sup> ... 2.5 mm <sup>2</sup>
Conductor cross-section, AWG	20 ... 12
Protective conductor foot	Yes
Mounting type	NS 35/7,5 NS 35/15 NS 32

Type	Item No.
TB 3-PE I	3059867

**ESSENTIAL edition | Feed-through terminal block, Screw connection, 4 mm<sup>2</sup>, 32 A, width 6,2 mm**



Common technical data	
Approvals	
Connection method	Screw connection
Connection cross-section	4 mm <sup>2</sup>
Width	6.2 mm
Number of connections	2
Number of rows	1
Conductor cross-section, rigid	0.5 mm <sup>2</sup> ... 6 mm <sup>2</sup>
Conductor cross-section, flexible	0.5 mm <sup>2</sup> ... 4 mm <sup>2</sup>
Conductor cross-section, AWG	20 ... 10
Mounting type	NS 35/7,5 NS 35/15 NS 32

Nominal current	Nominal voltage	Color	Protective conductor foot	Number of potentials	Type	Item No.
32 A	800 V	traffic grey B (RAL 7043)	No	1	TB 4 I	3246324
32 A	800 V	blue (RAL 5015)	No	1	TB 4 I BU	3057678
		green-yellow	Yes		TB 4-PE I	3059980

Accessories	Type	Item No.
Cover, 1,8 mm, dark gray	D-TB 4/10	3059809
Fixed bridge, 10-position, silver-colored	SCBI 10-6	3246120
Screw bridge, 10-position, silver-colored, with spring washer and insulating collar	SCBI 10-6 W	3000834
Insertion bridge, 10-position, gray, Bridging in the terminal point	INB 10-6	3246188
Insulation plate, for electrical isolation of neighboring bridges in the terminal center	TS-TB	3062838
Partition plate, 3 mm, dark gray	ATP-TB	3046272

ESSENTIAL edition | Multi-level terminal block, Screw connection, 4 mm<sup>2</sup>, width 6,2 mm



Common technical data	
Approvals	
Connection method	Screw connection
Connection cross-section	4 mm <sup>2</sup>
Width	6.2 mm
Number of connections	4
Number of rows	2
Nominal voltage	500 V
Conductor cross-section, rigid	0.5 mm <sup>2</sup> ... 6 mm <sup>2</sup>
Conductor cross-section, flexible	0.5 mm <sup>2</sup> ... 4 mm <sup>2</sup>
Conductor cross-section, AWG	20 ... 10
Protective conductor foot	No
Mounting type	NS 35/7,5 NS 35/15 NS 32
Number of potentials	2

Nominal current	Color	Type	Item No.
29 A	traffic grey B (RAL 7043)	TB 4-2L I	3246544
	blue (RAL 5015)	TB 4-2L I BU	3000957

Accessories	Type	Item No.
Cover, 2,5 mm, dark gray	D-TB 2,5/4-2L	3059964
Screw bridge, 10-position, silver-colored, with spring washer and insulating collar	SCBI 10-6 W	3000834
Insertion bridge, 10-position, gray, Bridging in the terminal point	INB 10-6	3246188
Insulation plate, width 0,5 mm, for electrical isolation of neighboring bridges in the terminal center	TS-TB-2L	3062841
Spacer plate, 2,5 mm, dark gray, compensates for the offset at the lower level when standard terminal blocks are mounted side-by-side	DP-TB-2L	3059977

ESSENTIAL edition | Multi-level terminal block, Screw connection, 4 mm<sup>2</sup>, width 6,2 mm



Common technical data	
Approvals	
Connection method	Screw connection
Connection cross-section	4 mm <sup>2</sup>
Width	6.2 mm
Number of connections	4
Number of rows	2
Nominal voltage	500 V
Conductor cross-section, rigid	0.5 mm <sup>2</sup> ... 6 mm <sup>2</sup>
Conductor cross-section, flexible	0.5 mm <sup>2</sup> ... 4 mm <sup>2</sup>
Conductor cross-section, AWG	20 ... 10
Protective conductor foot	No
Mounting type	NS 35/7,5 NS 35/15 NS 32

Color	Type	Item No.
traffic grey B (RAL 7043)	TB 4-L/LB I	3000905

Accessories	Type	Item No.
Cover, 2,5 mm, dark gray	D-TB 2,5/4-L/LB	3000906
Screw bridge, 10-position, silver-colored, with spring washer and insulating collar	SCBI 10-6 W	3000834
Insertion bridge, 10-position, gray, Bridging in the terminal point	INB 10-6	3246188
Insulation plate, width 0,5 mm, for electrical isolation of neighboring bridges in the terminal center	TS-TB-2L	3062841

### ESSENTIAL edition | Multi-level terminal block, Screw connection, 4 mm<sup>2</sup>, 32 A, width 6,2 mm



Technical data	
Approvals	ENEC
Connection method	Screw connection
Connection cross-section	4 mm <sup>2</sup>
Width	6.2 mm
Number of connections	4
Number of rows	2
Nominal current	32 A
Nominal voltage	500 V traffic grey B (RAL
Color	7043)
Conductor cross-section, rigid	0.5 mm <sup>2</sup> ... 6 mm <sup>2</sup>
Conductor cross-section, flexible	0.5 mm <sup>2</sup> ... 4 mm <sup>2</sup>
Conductor cross-section, AWG	20 ... 10
Protective conductor foot	No
Mounting type	NS 35/7,5 NS 35/15 NS 32

Type	Item No.
TB 4-L/LB-PV I	3000890

Accessories	Type	Item No.
Cover, 2,5 mm, dark gray	D-TB 2,5/4-L/LB	3000906
Screw bridge, 10-position, silver-colored, with spring washer and insulating collar	SCBI 10-6 W	3000834
Insertion bridge, 10-position, gray, Bridging in the terminal point	INB 10-6	3246188
Insulation plate, width 0,5 mm, for electrical isolation of neighboring bridges in the terminal center	TS-TB-2L	3062841

### ESSENTIAL edition | Motor connection terminal block, Screw connection, 4 mm<sup>2</sup>, 25 A, width 6,2 mm

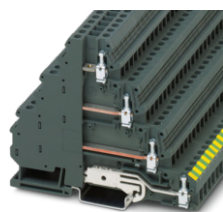

Technical data	
Approval	EAC cULus Recognized
Connection method	Screw connection
Connection cross-section	4 mm <sup>2</sup>
Width	6.2 mm
Number of connections	3
Number of rows	3
Nominal current	25 A
Nominal voltage	400 V
Color	traffic grey B (RAL 7043)
Conductor cross-section, rigid	0.5 mm <sup>2</sup> ... 6 mm <sup>2</sup>
Conductor cross-section, flexible	0.5 mm <sup>2</sup> ... 4 mm <sup>2</sup>
Conductor cross-section, AWG	20 ... 12
Mounting type	NS 35/7,5 NS 35/15 NS 32

Type	Item No.
TB 4-PE/3L I	3246833

Accessories	Type	Item No.
Fixed bridge, 10-position, silver-colored	SCBI 10-6	3246120
Screw bridge, 10-position, silver-colored, with spring washer and insulating collar	SCBI 10-6 W	3000834

ESSENTIAL edition | Multi-conductor terminal block, Screw connection, 4 mm<sup>2</sup>, 32 A, width 6,2 mm

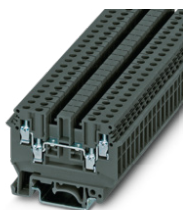

Common technical data	
Connection method	Screw connection
Connection cross-section	4 mm <sup>2</sup>
Width	6.2 mm
Number of connections	4
Number of rows	1
Nominal current	32 A
Nominal voltage	630 V
Conductor cross-section, rigid	0.5 mm <sup>2</sup> ... 6 mm <sup>2</sup>
Conductor cross-section, flexible	0.5 mm <sup>2</sup> ... 4 mm <sup>2</sup>
Conductor cross-section, AWG	20 ... 10
Protective conductor foot	No
Mounting type	NS 35/7,5 NS 35/15 NS 32
Number of potentials	1

Approvals	Color	Type	Item No.
	traffic grey B (RAL 7043)	TB 4-QUATTRO I	3246515
	blue (RAL 5015)	TB 4-QUATTRO I BU	3000947

Accessories	Type	Item No.
Cover, 1,5 mm, dark gray	D-TB 2,5/4-QUATTRO	3059838
Fixed bridge, 10-position, silver-colored	SCBI 10-6	3246120
Screw bridge, 10-position, silver-colored, with spring washer and insulating collar	SCBI 10-6 W	3000834
Insertion bridge, 10-position, gray, Bridging in the terminal point	INB 10-6	3246188
Insulation plate, width 0,5 mm, for electrical isolation of neighboring bridges in the terminal center	TS-TB-2L	3062841

ESSENTIAL edition | Multi-conductor terminal block, Screw connection, 4 mm<sup>2</sup>, 32 A, width 6,2 mm

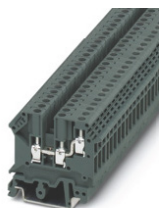

Common technical data	
Approvals	
Connection method	Screw connection
Connection cross-section	4 mm <sup>2</sup>
Width	6.2 mm
Number of connections	3
Number of rows	1
Nominal current	32 A
Nominal voltage	500 V
Conductor cross-section, rigid	0.5 mm <sup>2</sup> ... 4 mm <sup>2</sup>
Conductor cross-section, flexible	0.5 mm <sup>2</sup> ... 4 mm <sup>2</sup>
Conductor cross-section, AWG	20 ... 12
Protective conductor foot	No
Mounting type	NS 35/7,5 NS 35/15 NS 32
Number of potentials	1

Color	Type	Item No.
traffic grey B (RAL 7043)	TB 4-TWIN I	3246502
blue (RAL 5015)	TB 4-TWIN I BU	3000952

Accessories	Type	Item No.
Cover, 2 mm, dark gray	D-TB 2,5/4-TWIN	3059825
Fixed bridge, 10-position, silver-colored	SCBI 10-6	3246120
Screw bridge, 10-position, silver-colored, with spring washer and insulating collar	SCBI 10-6 W	3000834
Insertion bridge, 10-position, gray, Bridging in the terminal point	INB 10-6	3246188
Insulation plate, for electrical isolation of neighboring bridges in the terminal center	TS-TB	3062838

## Terminal blocks

### Feed-through terminal blocks, multi-conductor terminal blocks, and multi-level terminal blocks

#### ESSENTIAL edition | Feed-through terminal block, Screw connection, 6 mm<sup>2</sup>, 41 A, width 8,2 mm



##### Common technical data

Approvals	
Connection method	Screw connection
Connection cross-section	6 mm <sup>2</sup>
Width	8.2 mm
Number of connections	2
Number of rows	1
Conductor cross-section, rigid	1.5 mm <sup>2</sup> ... 6 mm <sup>2</sup>
Conductor cross-section, flexible	1.5 mm <sup>2</sup> ... 6 mm <sup>2</sup>
Mounting type	NS 35/7,5

NS 35/15  
NS 32

Nominal current	Nominal voltage	Color	Conductor cross-section, AWG	Protective conductor foot	Number of potentials	Type	Item No.
41 A	800 V	traffic grey B (RAL 7043)	14 ... 10	No	1	TB 6 I	3000486
41 A	800 V	blue (RAL 5015)	14 ... 10	No	1	TB 6 I BU	3057681
		green-yellow	24 ... 10	Yes		TB 6-PE I	3059870

##### Accessories

Accessories	Type	Item No.
Cover, 1,8 mm, dark gray	D-TB 4/10	3059809
Fixed bridge, 10-position, silver-colored	SCBI 10-8	3246133
Screw bridge, 10-position, silver-colored, with spring washer and insulating collar	SCBI 10-8 W	3000835
Insertion bridge, 10-position, gray, Bridging in the terminal point	INB 10-8	3246191
Insulation plate, for electrical isolation of neighboring bridges in the terminal center	TS-TB	3062838
Partition plate, 3 mm, dark gray	ATP-TB	3046272

#### ESSENTIAL edition | Feed-through terminal block, Screw connection, 10 mm<sup>2</sup>, 57 A, width 10,2 mm



##### Common technical data

Approvals	
Connection method	Screw connection
Connection cross-section	10 mm <sup>2</sup>
Width	10.2 mm
Number of connections	2
Number of rows	1
Conductor cross-section, rigid	1.5 mm <sup>2</sup> ... 16 mm <sup>2</sup>
Conductor cross-section, flexible	1.5 mm <sup>2</sup> ... 10 mm <sup>2</sup>
Conductor cross-section, AWG	14 ... 6
Mounting type	NS 35/7,5 NS 35/15 NS 32

Nominal current	Nominal voltage	Color	Protective conductor foot	Number of potentials	Type	Item No.
57 A	800 V	traffic grey B (RAL 7043)	No	1	TB 10 I	3246340
57 A	800 V	blue (RAL 5015)	No	1	TB 10 I BU	3057694
-	-	green-yellow	Yes		TB 10-PE I	3059883

##### Accessories

Accessories	Type	Item No.
Cover, 1,8 mm, dark gray	D-TB 4/10	3059809
Fixed bridge, 10-position, silver-colored	SCBI 10-10	3246146
Screw bridge, 10-position, silver-colored, with spring washer and insulating collar	SCBI 10-10 W	3000836
Insulation plate, for electrical isolation of neighboring bridges in the terminal center	TS-TB	3062838
Partition plate, 3 mm, dark gray	ATP-TB	3046272

ESSENTIAL edition | Multi-conductor terminal block, Screw connection, 10 mm<sup>2</sup>, 57 A, width 10,2 mm

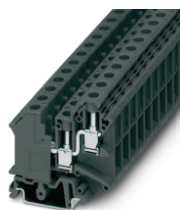

Technical data	
Approvals	UL
Connection method	Screw connection
Connection cross-section	10 mm <sup>2</sup>
Width	10,2 mm
Number of connections	3
Number of rows	1
Nominal current	57 A
Nominal voltage	800 V
Color	traffic grey B (RAL 7043)
Conductor cross-section, rigid	1.5 mm <sup>2</sup> ... 16 mm <sup>2</sup>
Conductor cross-section, flexible	1.5 mm <sup>2</sup> ... 10 mm <sup>2</sup>
Conductor cross-section, AWG	14 ... 6
Protective conductor foot	No
Mounting type	NS 35/7,5 NS 35/15 NS 32
Number of potentials	1

Type	Item No.
TB 10-TWIN I	3062812

Accessories	Type	Item No.
Fixed bridge, 10-position, silver-colored	SCBI 10-10	3246146
Screw bridge, 10-position, silver-colored, with spring washer and insulating collar	SCBI 10-10 W	3000836

ESSENTIAL edition | Feed-through terminal block, Screw connection, 16 mm<sup>2</sup>, 76 A, width 12,2 mm

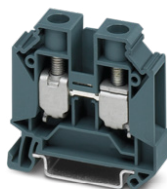

Common technical data	
Connection method	Screw connection
Connection cross-section	16 mm <sup>2</sup>
Width	12,2 mm
Number of connections	2
Number of rows	1
Conductor cross-section, rigid	6 mm <sup>2</sup> ... 16 mm <sup>2</sup>
Conductor cross-section, flexible	6 mm <sup>2</sup> ... 16 mm <sup>2</sup>
Conductor cross-section, AWG	8 ... 6

Approvals	Nominal current	Nominal voltage	Color	Protective conductor foot	Mounting type	Number of potentials	Type	Item No.
UL	76 A	1000 V	traffic grey B (RAL 7043)	No	NS 35/7,5 NS 35/15 NS 32	1	TB 16 I	3246353
UL	76 A	1000 V	blue (RAL 5015)	No	NS 35/7,5 NS 35/15 NS 32	1	TB 16 I BU	3076659
UL	-	-	green-yellow	Yes	NS 35/7,5 NS 35/15	-	TB 16-PE I	3059896

Accessories	Type	Item No.
Cover, 2,2 mm, dark gray	D-TB 16	3059922
Screw bridge, 10-position, silver-colored, with insulating collar	SCBI 10-12	3246159

ESSENTIAL edition | Feed-through terminal block, Screw connection, 35 mm<sup>2</sup>, 125 A, width 15,2 mm



Common technical data	
Approvals	UL
Connection method	Screw connection
Connection cross-section	35 mm <sup>2</sup>
Width	15,2 mm
Number of connections	2
Number of rows	1
Conductor cross-section, rigid	10 mm <sup>2</sup> ... 35 mm <sup>2</sup>
Conductor cross-section, flexible	10 mm <sup>2</sup> ... 35 mm <sup>2</sup>
Conductor cross-section, AWG	6 ... 2
Mounting type	NS 35/7,5 NS 35/15

Nominal current	Nominal voltage	Color	Protective conductor foot	Number of potentials	Type	Item No.
125 A	1000 V	traffic grey B (RAL 7043)	No	1	TB 35 I	3246366
125 A	1000 V	blue (RAL 5015)	No	1	TB 35 I BU	3076662
-	-	green-yellow	Yes	-	TB 35-PE I	3059906

Accessories	Type	Item No.
End cover, 2,2 mm, dark gray	D-TB 35	3059935
Fixed bridge, 2-position, silver-colored, with insulating collar	SCBI 2-15	3246162
Fixed bridge, 3-position, silver-colored, with insulating collar	SCBI 3-15	3246573
Fixed bridge, 5-position, silver-colored, with insulating collar	SCBI 5-15	3246612

## Terminal blocks

### Feed-through terminal blocks, multi-conductor terminal blocks, and multi-level terminal blocks

#### ESSENTIAL edition | Feed-through terminal block, Screw connection, 50 mm<sup>2</sup>, 150 A, width 20 mm



Common technical data	
Connection method	Screw connection
Connection cross-section	50 mm <sup>2</sup>
Width	20 mm
Number of connections	2
Number of rows	1
Conductor cross-section, AWG	4 ... 2/0

Approvals	Nominal current	Nominal voltage	Color	Conductor cross-section, rigid	Conductor cross-section, flexible	Protective conductor foot	Mounting type	Type	Item No.
	150 A	1000 V	traffic grey B (RAL 7043)	16 mm <sup>2</sup> ... 70 mm <sup>2</sup>	25 mm <sup>2</sup> ... 70 mm <sup>2</sup>	No	NS 35/7,5 NS 35/15	TB 50 I	<a href="#">3247180</a>
	150 A	1000 V	blue (RAL 5015)	16 mm <sup>2</sup> ... 70 mm <sup>2</sup>	25 mm <sup>2</sup> ... 70 mm <sup>2</sup>	No	NS 35/7,5 NS 35/15	TB 50 I BU	<a href="#">3247187</a>
	-	-	green-yellow	16 mm <sup>2</sup> ... 50 mm <sup>2</sup>	25 mm <sup>2</sup> ... 50 mm <sup>2</sup>	Yes	NS 35/7,5 NS 35/15 NS 32	TB 50-PE I	<a href="#">3251206</a>

Accessories	Type	Item No.
Screw bridge, 2-position, silver-colored, with insulating collar	SCBI 2-20 N	<a href="#">3247222</a>
Screw bridge, 3-position, silver-colored, with insulating collar	SCBI 3-20 N	<a href="#">3247229</a>

#### ESSENTIAL edition | Feed-through terminal block, Screw connection, 70 mm<sup>2</sup>, 192 A, width 20,3 mm



Common technical data	
Approvals	
Connection method	Screw connection
Width	20.3 mm
Number of connections	2
Number of rows	1
Nominal current	192 A
Nominal voltage	1000 V
Conductor cross-section, rigid	16 mm <sup>2</sup> ... 95 mm <sup>2</sup>
Conductor cross-section, flexible	25 mm <sup>2</sup> ... 70 mm <sup>2</sup>
Conductor cross-section, AWG	4 ... 3/0

Connection cross-section	Color	Protective conductor foot	Mounting type	Type	Item No.
70 mm <sup>2</sup>	traffic grey B (RAL 7043)	No	NS 35/7,5 NS 35/15	TB 70 I	<a href="#">3247194</a>
70 mm <sup>2</sup>	blue (RAL 5015)	No	NS 35/7,5 NS 35/15	TB 70 I BU	<a href="#">3247201</a>
95 mm <sup>2</sup>	green-yellow	Yes	NS 35/7,5 NS 35/15 NS 32	TB 70-PE I	<a href="#">3251207</a>

Accessories	Type	Item No.
Screw bridge, 2-position, silver-colored, with insulating collar	SCBI 2-20 N	<a href="#">3247222</a>
Screw bridge, 3-position, silver-colored, with insulating collar	SCBI 3-20 N	<a href="#">3247229</a>

#### ESSENTIAL edition | Feed-through terminal block, Screw connection, 95 mm<sup>2</sup>, 232 A, width 25 mm



Common technical data	
Connection method	Screw connection
Connection cross-section	95 mm <sup>2</sup>
Width	25 mm
Number of connections	2
Number of rows	1
Conductor cross-section, rigid	25 mm <sup>2</sup> ... 95 mm <sup>2</sup>
Conductor cross-section, flexible	35 mm <sup>2</sup> ... 95 mm <sup>2</sup>
Conductor cross-section, AWG	2 ... 3/0

Approvals	Nominal current	Nominal voltage	Color	Protective conductor foot	Mounting type	Number of potentials	Type	Item No.
	232 A	1000 V	traffic grey B (RAL 7043)	No	NS 35/15 NS 32	1	TB 95 I	<a href="#">3251200</a>
	232 A	1000 V	blue (RAL 5015)	No	NS 35/15 NS 32	1	TB 95 I BU	<a href="#">3251203</a>
	-	-	green-yellow	Yes	NS 35/7,5 NS 35/15 NS 32	-	TB 95-PE I	<a href="#">3251208</a>

Accessories	Type	Item No.
Insertion bridge, 2-position, gray, Bridging in the terminal point	INB 2-25	<a href="#">3251212</a>

**ESSENTIAL edition | Feed-through terminal block, Screw connection, 150 mm<sup>2</sup>, 309 A, width 31 mm**



Common technical data	
Connection method	Screw connection
Connection cross-section	150 mm <sup>2</sup>
Width	31 mm
Number of connections	2
Number of rows	1
Nominal current	309 A
Nominal voltage	1000 V
Conductor cross-section, rigid	35 mm <sup>2</sup> ... 150 mm <sup>2</sup>
Conductor cross-section, flexible	50 mm <sup>2</sup> ... 150 mm <sup>2</sup>
Conductor cross-section, AWG	1/0 ... 250 kcmil
Protective conductor foot	No
Mounting type	NS 35/15 NS 32
Number of potentials	1

Approvals	Color	Type	Item No.
	traffic grey B (RAL 7043)	TB 150 I	<a href="#">3251201</a>

Accessories	Type	Item No.
Insertion bridge, 2-position, gray, Bridging in the terminal point	INB 2-31	<a href="#">3251214</a>
Insertion bridge, 3-position, gray, Bridging in the terminal point	INB 3-31	<a href="#">3251215</a>

**ESSENTIAL edition | Feed-through terminal block, Screw connection, 240 mm<sup>2</sup>, 415 A, width 36 mm**



Common technical data	
Connection method	Screw connection
Connection cross-section	240 mm <sup>2</sup>
Width	36 mm
Number of connections	2
Number of rows	1
Nominal current	415 A
Nominal voltage	1000 V
Conductor cross-section, rigid	70 mm <sup>2</sup> ... 240 mm <sup>2</sup>
Conductor cross-section, flexible	70 mm <sup>2</sup> ... 240 mm <sup>2</sup>
Conductor cross-section, AWG	3/0 ... 250 kcmil
Protective conductor foot	No
Mounting type	NS 35/15 NS 32
Number of potentials	1

Approvals	Color	Type	Item No.
	traffic grey B (RAL 7043)	TB 240 I	<a href="#">3251202</a>

Accessories	Type	Item No.
Insertion bridge, 2-position, gray, Bridging in the terminal point	INB 2-36	<a href="#">3251216</a>

## Terminal blocks

### Sensor terminal blocks and actuator terminal blocks

#### Sensor terminal blocks and actuator terminal blocks for clear signal wiring

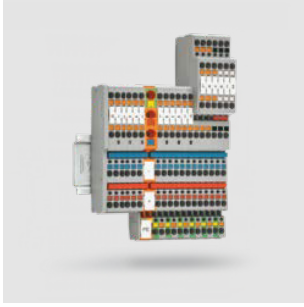

Thanks to their compact design, the PTIO sensor/actuator terminal blocks are tailored to the wiring of modern machine control systems. The sensor/actuator terminal blocks enable you to wire bipolar initiators and actuators with a terminal width of just 3.5 mm. In addition, you are able to wire the terminal blocks with 3- or 4-conductor sensors and actuators.

#### ESSENTIAL edition | Sensor/actuator terminal block, Screw connection, 2,5 mm<sup>2</sup>, 20 A, width 6,2 mm



Technical data	
Approvals	UL
Connection method	Screw connection
Connection cross-section	2.5 mm <sup>2</sup>
Width	6.2 mm
Number of connections	3
Number of rows	3
Nominal voltage	250 V
Color	traffic grey B (RAL 7043)
Conductor cross-section, rigid	0.2 mm <sup>2</sup> ... 4 mm <sup>2</sup>
Conductor cross-section, flexible	0.2 mm <sup>2</sup> ... 2.5 mm <sup>2</sup>
Conductor cross-section, AWG	24 ... 14
Mounting type	NS 35/7,5 NS 35/15

Type	Item No.
TBIO 2,5 I	3246749

Accessories		Type	Item No.
Screw bridge, 10-position, silver-colored, with spring washer and insulating collar		SCBI 10-6 W	3000834
Insertion bridge, 80-position, blue, Bridging in the terminal point, latching in the terminal housing		INB IO 80-6 BU	3246931
Insertion bridge, 80-position, red, Bridging in the terminal point, latching in the terminal housing		INB IO 80-6 RD	3246938
Partition plate, 2 mm, dark gray		ATP-TB/3	3246959

#### ESSENTIAL edition | Sensor/actuator terminal block, Screw connection, 2,5 mm<sup>2</sup>, 20 A, width 6,2 mm

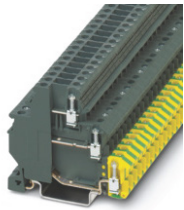

Technical data	
Approvals	UL
Connection method	Screw connection
Connection cross-section	2.5 mm <sup>2</sup>
Width	6.2 mm
Number of connections	3
Number of rows	3
Nominal voltage	250 V
Color	traffic grey B (RAL 7043)
Conductor cross-section, rigid	0.2 mm <sup>2</sup> ... 4 mm <sup>2</sup>
Conductor cross-section, flexible	0.2 mm <sup>2</sup> ... 2.5 mm <sup>2</sup>
Conductor cross-section, AWG	24 ... 14
Protective conductor foot	Yes
Mounting type	NS 35/7,5 NS 35/15

Type	Item No.
TBIO 2,5-PE/L/L I	3246889

Accessories		Type	Item No.
Screw bridge, 10-position, silver-colored, with spring washer and insulating collar		SCBI 10-6 W	3000834
Insertion bridge, 80-position, blue, Bridging in the terminal point, latching in the terminal housing		INB IO 80-6 BU	3246931
Insertion bridge, 80-position, red, Bridging in the terminal point, latching in the terminal housing		INB IO 80-6 RD	3246938
Partition plate, 2 mm, dark gray		ATP-TB/3	3246959

ESSENTIAL edition | Sensor/actuator disconnect terminal block, Screw connection, 2,5 mm<sup>2</sup>, 15 A, width 6,2 mm

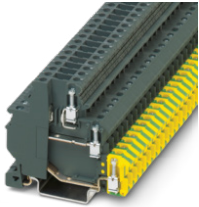

Technical data	
Approvals	UL, CE
Connection method	Screw connection
Connection cross-section	2.5 mm <sup>2</sup>
Width	6.2 mm
Number of connections	3
Number of rows	3
Nominal voltage	250 V
Color	traffic grey B (RAL 7043)
Conductor cross-section, rigid	0.2 mm <sup>2</sup> ... 4 mm <sup>2</sup>
Conductor cross-section, flexible	0.2 mm <sup>2</sup> ... 2.5 mm <sup>2</sup>
Conductor cross-section, AWG	24 ... 14
Protective conductor foot	Yes
Mounting type	NS 35/7,5 NS 35/15

Type	Item No.
TBIO 2,5-PE/L/TG I	3246903

Accessories	Type	Item No.
Fuse plug, G / 5 x 20, width 6,1 mm	FP IO (5X20)	3246980
Fuse plug, G / 5 x 20, width 6,1 mm, with LED display for 15-30 V AC/DC	FP IO (5X20) LED 24	3246994
Insertion bridge, 80-position, blue, Bridging in the terminal point, latching in the terminal housing	INB IO 80-6 BU	3246931
Insertion bridge, 80-position, red, Bridging in the terminal point, latching in the terminal housing	INB IO 80-6 RD	3246938
Partition plate, 2 mm, dark gray	ATP-TB/3	3246959

## Terminal blocks

### Fuse terminal blocks, component terminal blocks, and diode terminal blocks

#### Fuse terminal blocks, component terminal blocks, and diode terminal blocks

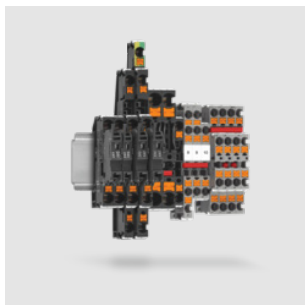

With fuse terminal blocks, you can accommodate fuses in different designs and with different nominal currents. Using multi-level versions, you can route a protected potential and an unprotected potential through just one terminal block. Versions for use in potentially explosive areas with Ex nA type of protection extend the field of application. Together with the component terminal blocks and diode terminal blocks, terminal blocks with LEDs, blocking diodes, or resistors are also available.

#### ESSENTIAL edition | Multi-level fuse terminal block, Screw connection, 4 mm<sup>2</sup>, 30 A, width 8,2 mm

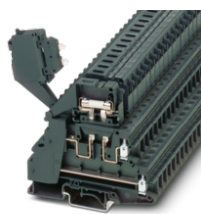

Technical data	
Approvals	UL, ENEC
Connection method	Screw connection
Connection cross-section	4 mm <sup>2</sup>
Width	8.2 mm
Number of connections	4
Number of rows	2
Nominal current	30 A
Nominal voltage	400 V
Color	traffic grey B (RAL 7043)
Conductor cross-section, rigid	0.5 mm <sup>2</sup> ... 6 mm <sup>2</sup>
Conductor cross-section, flexible	0.5 mm <sup>2</sup> ... 4 mm <sup>2</sup>
Conductor cross-section, AWG	20 ... 12
Fuse type	G / 5 x 20
Mounting type	NS 35/7,5 NS 35/15 NS 32
<b>Type</b>	TB 4-2L-HESI (5X20) I
<b>Item No.</b>	3246847

Accessories	
Screw bridge, 10-position, silver-colored, with spring washer and insulating collar	<b>Type</b> SCBI 10-8 W <b>Item No.</b> 3000835
Insertion bridge, 10-position, dark gray, Bridging in the terminal point	<b>Type</b> INBS 10-8 <b>Item No.</b> 3247159

#### ESSENTIAL edition | Multi-level fuse terminal block, Screw connection, 4 mm<sup>2</sup>, 30 A, width 8,2 mm

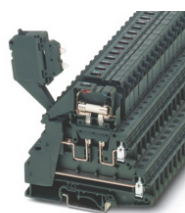

Common technical data	
Connection method	Screw connection
Connection cross-section	4 mm <sup>2</sup>
Width	8.2 mm
Number of connections	4
Number of rows	2
Nominal current	30 A
Conductor cross-section, rigid	0.5 mm <sup>2</sup> ... 6 mm <sup>2</sup>
Conductor cross-section, flexible	0.5 mm <sup>2</sup> ... 4 mm <sup>2</sup>
Conductor cross-section, AWG	20 ... 12
Fuse type	G / 5 x 20
Mounting type	NS 35/7,5 NS 35/15 NS 32

Approvals	Nominal voltage	Type	Item No.
UL	24 V (the voltage is determined by the light indicator.)	TB 4-2L-HESILED 24 (5X20) I	3246854
ENEC	250 V (the voltage is determined by the light indicator.)	TB 4-2L-HESILA 250 (5X20) I	3246819

Accessories	
Screw bridge, 10-position, silver-colored, with spring washer and insulating collar	<b>Type</b> SCBI 10-8 W <b>Item No.</b> 3000835
Insertion bridge, 10-position, dark gray, Bridging in the terminal point	<b>Type</b> INBS 10-8 <b>Item No.</b> 3247159

ESSENTIAL edition | Lever-type disconnect terminal block, Screw connection, 4 mm<sup>2</sup>, 16 A, width 8,2 mm



Technical data	
Approvals	
Connection method	Screw connection
Connection cross-section	4 mm <sup>2</sup>
Width	8.2 mm
Number of connections	2
Number of rows	1
Nominal current	16 A
Nominal voltage	500 V
Color	traffic grey B (RAL 7043)
Conductor cross-section, rigid	0.5 mm <sup>2</sup> ... 6 mm <sup>2</sup>
Conductor cross-section, flexible	0.5 mm <sup>2</sup> ... 4 mm <sup>2</sup>
Conductor cross-section, AWG	20 ... 12
Fuse type	Bridge
Mounting type	NS 35/7,5 NS 35/15 NS 32
Number of potentials	1

Type	Item No.
TB 4-HEDI I	3246421

Accessories	Type	Item No.
Cover, 2,2 mm, dark gray	D-TB 4-HESI	3059812
Insertion bridge, 10-position, dark gray, Bridging in the terminal point	INBS 10-8	3247159

ESSENTIAL edition | Fuse terminal block, Screw connection, 4 mm<sup>2</sup>, 6,3 A, width 8,2 mm

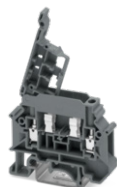

Common technical data	
Approvals	
Connection method	Screw connection
Connection cross-section	4 mm <sup>2</sup>
Width	8.2 mm
Number of connections	2
Number of rows	1
Nominal voltage	500 V (the voltage is determined by the fuse used)
Conductor cross-section, rigid	0.5 mm <sup>2</sup> ... 6 mm <sup>2</sup>
Conductor cross-section, flexible	0.5 mm <sup>2</sup> ... 4 mm <sup>2</sup>
Conductor cross-section, AWG	20 ... 12
Fuse type	G / 5 x 20
Mounting type	NS 35/7,5 NS 35/15 NS 32
Number of potentials	1

Nominal current	Color	Type	Item No.
6.3 A	traffic grey B (RAL 7043)	TB 4-HESI (5X20) I	3246418

Accessories	Type	Item No.
Cover, 2,2 mm, dark gray	D-TB 4-HESI	3059812
Insertion bridge, 10-position, dark gray, Bridging in the terminal point	INBS 10-8	3247159

ESSENTIAL edition | Fuse terminal block, Screw connection, 4 mm<sup>2</sup>, 6,3 A, width 8,2 mm

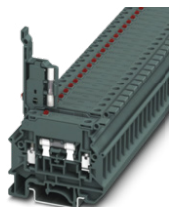

Common technical data	
Approvals	
Connection method	Screw connection
Connection cross-section	4 mm <sup>2</sup>
Width	8.2 mm
Number of connections	2
Number of rows	1
Nominal current	6.3 A
Color	traffic grey B (RAL 7043)
Conductor cross-section, rigid	0.5 mm <sup>2</sup> ... 6 mm <sup>2</sup>
Conductor cross-section, flexible	0.5 mm <sup>2</sup> ... 4 mm <sup>2</sup>
Conductor cross-section, AWG	20 ... 12
Fuse type	G / 5 x 20
Mounting type	NS 35/7,5 NS 35/15 NS 32
Number of potentials	1

Nominal voltage	Type	Item No.
24 V (the voltage is determined by the light indicator.)	TB 4-HESILED 24 (5X20) I	3246434
60 V (the voltage is determined by the light indicator.)	TB 4-HESILED 60 (5X20) I	3246447
250 V (the voltage is determined by the light indicator.)	TB 4-HESILA 250 (5X20) I	3246450

Accessories	Type	Item No.
Cover, 2,2 mm, dark gray	D-TB 4-HESI	3059812
Insertion bridge, 10-position, dark gray, Bridging in the terminal point	INBS 10-8	3247159

**Plug-in terminal blocks**

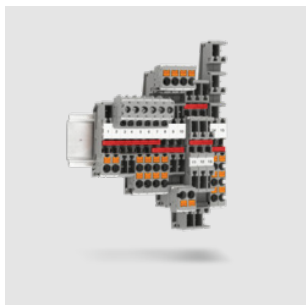

The plug-in COMBI terminal blocks are a special form of hybrid terminal blocks. The terminal blocks have a standardized plug-in zone on one side and Push-in, screw, spring-cage or fast-connection technology on the other side. Due to the contact system, they can withstand extreme vibration levels. The plug-in terminal blocks save you a lot of time when carrying out signal and power wiring.

**ESSENTIAL edition | Pluggable feed-through terminal block, Screw/plug-in connection, 2,5 mm<sup>2</sup>, 12 A, width 5,08 mm**



Technical data	
Approvals	
Connection method	Screw/plug-in connection
Connection cross-section	2.5 mm <sup>2</sup>
Width	5.08 mm
Number of connections	2
Number of rows	1
Nominal current	12 A
Nominal voltage	250 V
Color	traffic grey B (RAL 7043)
Conductor cross-section, rigid	0.2 mm <sup>2</sup> ... 4 mm <sup>2</sup>
Conductor cross-section, flexible	0.2 mm <sup>2</sup> ... 2.5 mm <sup>2</sup>
Conductor cross-section, AWG	24 ... 12
Mounting type	NS 35/7,5 NS 35/15 NS 32

		Type	Item No.
		TB 2,5-BCVP/1P I	<a href="#">3247075</a>

Accessories		Type	Item No.
Cover, 2,4 mm, dark gray		D-TB 2,5-BCVP/1P	<a href="#">3247117</a>

Disconnect and knife-disconnect terminal blocks

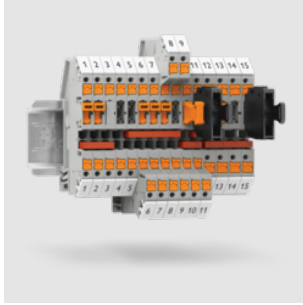

Particularly in testing and measurement technology, various terminal blocks are used which enable the easy manual disconnection of circuits. The knife-disconnect terminal blocks from Phoenix Contact have an easy-to-operate lever disconnect knife. The basic disconnect terminal blocks have a standardized disconnect zone for accommodating component connectors, fuse plugs, isolating plugs or feed-through connectors.

ESSENTIAL edition | Disconnect terminal block, Screw connection, 4 mm², 16 A, width 6,15 mm



Common technical data	
Approvals	
Connection method	Screw connection
Connection cross-section	4 mm²
Width	6.15 mm
Number of connections	2
Number of rows	1
Nominal current	16 A
Nominal voltage	800 V
Conductor cross-section, rigid	0.5 mm² ... 6 mm²
Conductor cross-section, flexible	0.5 mm² ... 4 mm²
Conductor cross-section, AWG	20 ... 10
Protective conductor foot	No
Mounting type	NS 35/7,5 NS 35/15 NS 32
Number of potentials	1

Color	Type	Item No.
traffic grey B (RAL 7043)	TB 4-MT I	3246379

Accessories	Type	Item No.
Cover, 1,8 mm, dark gray	D-TB 4/10	3059809
Insertion bridge, 10-position, gray, Bridging in the terminal point	INB 10-6	3246188

ESSENTIAL edition | Knife-disconnect terminal block, Screw connection, 4 mm², 16 A, width 6,2 mm



Technical data	
Approvals	
Connection method	Screw connection
Connection cross-section	4 mm²
Width	6.2 mm
Number of connections	2
Number of rows	1
Nominal current	16 A
Nominal voltage	500 V
Color	traffic grey B (RAL 7043)
Conductor cross-section, rigid	0.5 mm² ... 6 mm²
Conductor cross-section, flexible	0.5 mm² ... 4 mm²
Conductor cross-section, AWG	20 ... 10
Protective conductor foot	No
Mounting type	NS 35/7,5 NS 35/15 NS 32

Type	Item No.
TB 4-MT N I	3000607

Accessories	Type	Item No.
Cover, 1,8 mm, dark gray	D-TB 4/10	3059809
Insertion bridge, 10-position, gray, Bridging in the terminal point	INB 10-6	3246188

**ESSENTIAL edition | Disconnect terminal block, Screw connection, 4 mm<sup>2</sup>, 16 A, width 6,15 mm**



Technical data	
Approvals	
Connection method	Screw connection
Connection cross-section	4 mm <sup>2</sup>
Width	6.15 mm
Number of connections	2
Number of rows	1
Nominal current	16 A
Nominal voltage	800 V
Color	traffic grey B (RAL 7043)
Conductor cross-section, rigid	0.5 mm <sup>2</sup> ... 6 mm <sup>2</sup>
Conductor cross-section, flexible	0.5 mm <sup>2</sup> ... 4 mm <sup>2</sup>
Conductor cross-section, AWG	20 ... 10
Protective conductor foot	No
Mounting type	NS 35/7,5 NS 35/15 NS 32
Number of potentials	1

Type	Item No.
TB 4-MT-P/P I	3246405

Accessories		Type	Item No.
Cover, 1,8 mm, dark gray		D-TB 4/10	3059809
Insertion bridge, 10-position, gray, Bridging in the terminal point		INB 10-6	3246188

**ESSENTIAL edition | Feed-through terminal block, Screw connection, 4 mm<sup>2</sup>, 32 A, width 8,2 mm**

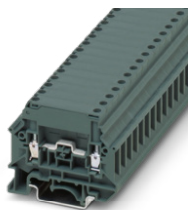

Technical data	
Approvals	
Connection method	Screw connection
Connection cross-section	4 mm <sup>2</sup>
Width	8.2 mm
Number of connections	2
Number of rows	1
Nominal current	32 A
Nominal voltage	800 V
Color	traffic grey B (RAL 7043)
Conductor cross-section, rigid	0.5 mm <sup>2</sup> ... 6 mm <sup>2</sup>
Conductor cross-section, flexible	0.5 mm <sup>2</sup> ... 4 mm <sup>2</sup>
Conductor cross-section, AWG	20 ... 10
Protective conductor foot	No
Mounting type	NS 35/7,5 NS 35/15 NS 32

Type	Item No.
TB 4-MTD I	3000605

Accessories		Type	Item No.
Cover, 2,2 mm, dark gray		D-TB 4-HESI	3059812
Insertion bridge, 10-position, dark gray, Bridging in the terminal point		INBS 10-8	3247159

ESSENTIAL edition | Disconnect terminal block, Screw connection, 4 mm<sup>2</sup>, 16 A, width 6,2 mm



Technical data	
Approvals	
Connection method	Screw connection
Connection cross-section	4 mm <sup>2</sup>
Width	6.2 mm
Number of connections	2
Number of rows	1
Nominal current	16 A
Nominal voltage	800 V
Color	traffic grey B (RAL 7043)
Conductor cross-section, rigid	0.5 mm <sup>2</sup> ... 6 mm <sup>2</sup>
Conductor cross-section, flexible	0.5 mm <sup>2</sup> ... 4 mm <sup>2</sup>
Conductor cross-section, AWG	20 ... 10
Protective conductor foot	No
Mounting type	NS 35/7,5 NS 35/15 NS 32
Number of potentials	1

Type	Item No.
TB 4-TG I	3246382

Accessories		Type	Item No.
Fuse plug, G / 5 x 20, width 6,2 mm, alternating arrangement on 5.2 mm disconnect terminal blocks		FP (5X20)	3214039
Fuse plug, G / 5 x 20, width 6,2 mm, with LED display for 15-30 V AC/DC, alternating arrangement on 5.2 mm disconnect terminal blocks		FP (5X20) 24	3214042
Component connector, dark gray, for receiving diodes or resistors		CP	3214071
Cover, 1,8 mm, dark gray		D-TB 4/10	3059809
Insertion bridge, 10-position, gray, Bridging in the terminal point		INB 10-6	3246188

ESSENTIAL edition | Test disconnect terminal block, Screw connection, 41 A, width 8,2 mm



Technical data	
Approvals	
Connection method	Screw connection
Width	8.2 mm
Number of connections	2
Number of rows	1
Nominal current	41 A
Nominal voltage	800 V
Color	traffic grey B (RAL 7043)
Conductor cross-section, rigid	1.5 mm <sup>2</sup> ... 6 mm <sup>2</sup>
Conductor cross-section, flexible	1.5 mm <sup>2</sup> ... 6 mm <sup>2</sup>
Conductor cross-section, AWG	14 ... 10
Protective conductor foot	No
Mounting type	NS 35/7,5 NS 35/15 NS 32
Number of potentials	1

Type	Item No.
TB 6-T I	3246463

Accessories		Type	Item No.
Cover, 2,2 mm, dark gray		D-TB 6-T	3059951
Screw bridge, 10-position, silver-colored, with insulating collar		SCBI 10-8,15	3245134
Isolator bridge bar, 10-position, silver-colored, for switchable cross bridges, with insulating collar		SCBI 10-8,15 ISO	3000417

# Industrial communication



## Industrial communication

Industrial communication modules feature precision connection functions for the use of serial cables. Whether the application requires wireless data transmission over distances of up to 5 km or a global Ethernet connection, the ESSENTIAL edition communication modules feature the right components for you.

## Product range overview

---

Industrial Wireless ESSENTIAL edition	<b>62</b>
Device servers and gateways ESSENTIAL edition	<b>63</b>

---

## Wireless modules for serial cable replacement



Industrial communication modules feature precision connectivity functions for the use of serial cables. Whether the application requires wireless data transmission over distances of 5 km or global Ethernet connectivity, the ESSENTIAL edition communication modules feature the right components for you.

The ESSENTIAL edition wireless modules with essential functions reliably transmit your serial data. They ensure a higher availability than comparable wireless technologies thanks to a high number of narrowband wireless channels, along with an automatic and manual coexistence mechanism. Convenient and clear software assistants ensure quick and easy installation. Moreover, their international approvals package allows you to use them anywhere in the world. The ESSENTIAL edition wireless module is ideal for use in environments with electromagnetic interference because the wireless communication in the 2.4 GHz band is immune to external EMI, and is therefore perfect for use in photovoltaic systems.

The ESSENTIAL edition device server features flexible options for transmitting serial data via Ethernet. With the switchboard component housing and the standard operating environments, this device server is perfectly suited for commercial and IT applications. Numerous serial interface profiles simplify the configuration process for the Modbus gateway functionality. This enables seamless communication between Modbus/ASCII, Modbus/RTU, and Modbus/TCP devices.



With Trusted Wireless modules, you obtain reliable, interference-free communication, particularly in environments with electromagnetic disturbance.



Commission the wireless connection intuitively. The convenient Software Wizard will assist you.



You can use the wireless modules everywhere in your applications. Thanks to the license-free 2.4 GHz frequency band and an international approval package, the devices can be used worldwide.



Numerous serial interface profiles simplify the configuration process for the Modbus gateway functionality. The profiles support the simultaneous connection with several hosts, including up to 1,024 incoming bases and up to 49 outgoing bases.

- Your advantages:**
- For worldwide use, thanks to the license-free 2.4 GHz ISM band
  - Intuitive commissioning of the wireless connection using the convenient Software Wizard
  - Reliable, interference-free communication even over long distances, thanks to Trusted Wireless technology
  - Simplified configuration with individual profiles
  - Simultaneous connection to several hosts

**Industrial Wireless ESSENTIAL edition**



The ESSENTIAL edition wireless module with essential functions reliably transmits your serial data. With Trusted Wireless technology, you obtain reliable, interference-free communication, particularly in environments with electromagnetic disturbance. With the license-free 2.4 GHz frequency band and the international approval package, the wireless module can be used worldwide.

**Wireless module, Trusted Wireless**

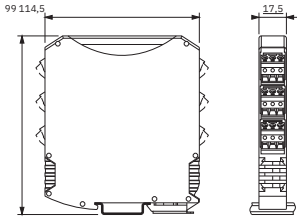

Technical data	
Application	RS-485
Function	Bidirectional Wireless transceiver MESH
Frequency band	2.4 GHz
Wireless standard	Trusted Wireless
Supply voltage	24 V DC
Supply voltage range	19.2 V DC ... 30.5 V DC
Connection method	Screw connection
Degree of protection	IP20
Ambient temperature (operation)	-20 °C ... 70 °C -4 °F ... 158 °F
Wireless approval	Europe, USA, Canada, additional countries in the e-shop

Type	Item No.
RAD-EE-2400-RS485	1081818

Device servers and gateways ESSENTIAL edition



The ESSENTIAL edition device server features flexible options for transmitting serial data via Ethernet. Numerous serial interface profiles simplify the configuration process for the Modbus gateway functionality.

Interface converter



Technical data	
Communication protocol	Ethernet interface, 10/100Base-T(X) in accordance with IEEE 802.3
Interface	Ethernet RS-232 RS-422 RS-485
Connection method	RJ45 jack, shielded
Connection method	D-SUB 9 plug
Connection method (RS-422)	D-SUB 9 plug
Connection method (RS-485)	D-SUB 9 plug
Number of channels	1
Transmission speed	10/100 Mbps, auto negotiation
Transmission length	≤ 100 m (shielded twisted pair)
Transmission length	15 m
Transmission length (RS-422)	≤ 1200 m
Degree of protection	IP40
Ambient temperature (operation)	0 °C ... 55 °C

# Signal conditioners and measuring transducers



## Signal conditioners and measuring transducers

With our signal conditioners and measuring transducers, process signals can be galvanically isolated, converted, filtered and amplified to get an application without interference and faults. Signal conditioners and measuring transducers from the ESSENTIAL edition product family offer you signal conditioning in the most common areas. The focus is on basic functionality that covers 90% of applications.

## Product range overview

---

Signal conditioners and measuring transducers for standard applications ESSENTIAL edition

---

**67**

## MINI Analog

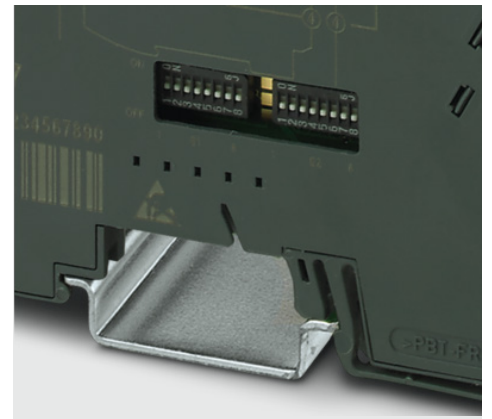
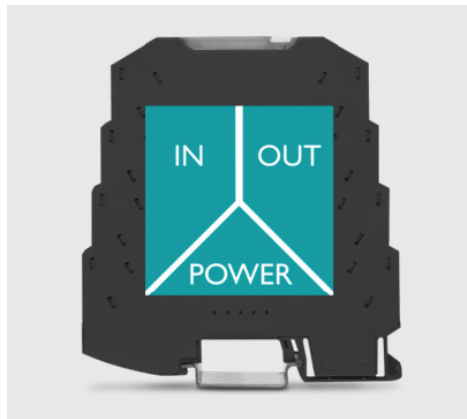
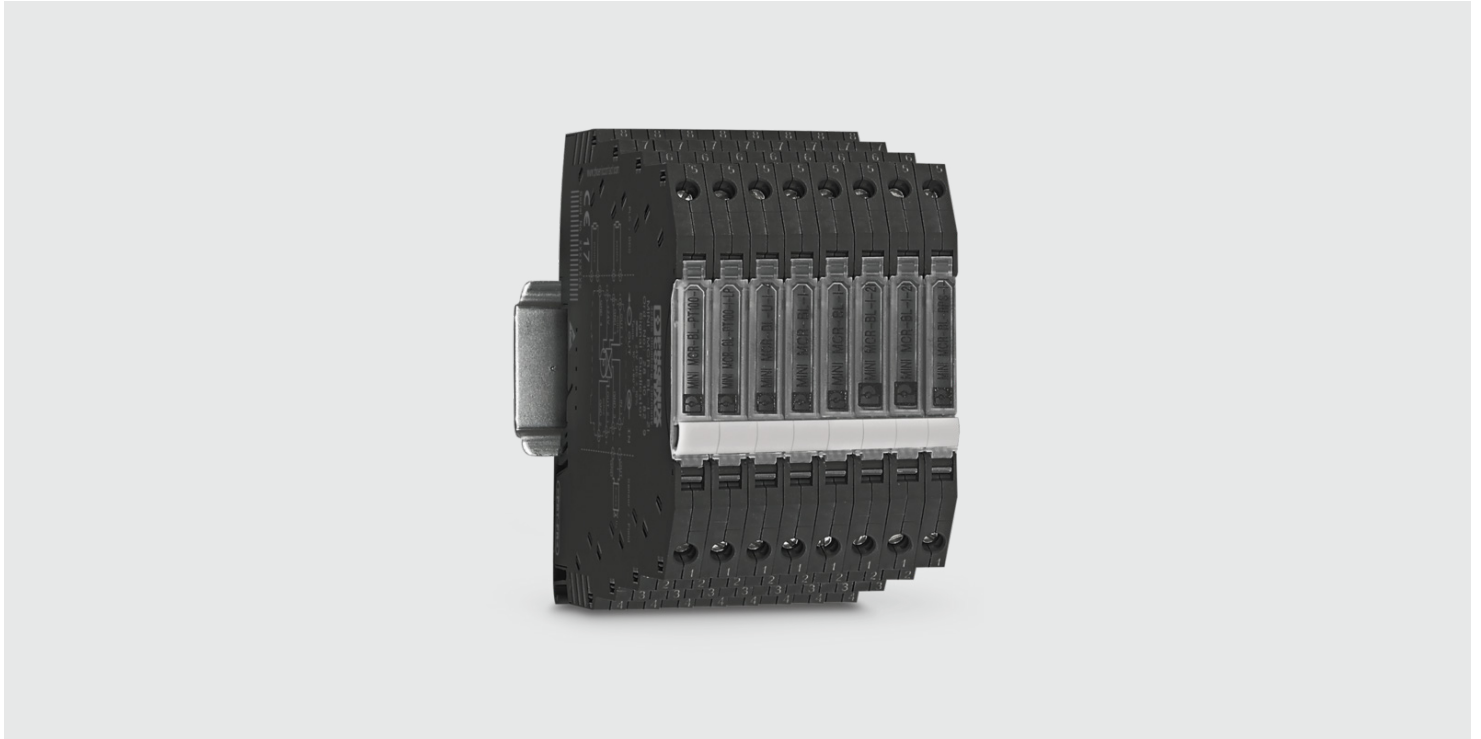

### Highly compact and focused

The highly compact signal conditioners MINI Analog ESSENTIAL edition offer basic functionality focused on the main signals used in the market. The modules save space in your cabinet.

### Easy and Safe

Easy in use without software. Focused on DIP-Switches. Safe and correct signals because of consistent galvanic isolation of Inputs, Outputs and Power.

### Your advantages:

- Space saving with only 6,2 mm width
- Easy in use with DIP switch configuration
- Correct signals with consistent galvanic isolation
- High temperature range with low power loss

## Signal conditioners and measuring transducers for standard applications ESSENTIAL edition



The highly compact MINI Analog signal conditioners from the ESSENTIAL Edition product family offer basic functionality focused on the main signals used in the market. The modules save space in your control cabinet.

## ESSENTIAL edition, Input signal conditioner, Input signal Current, Output signal Current



Technical data	
Number of channels	1
Connection method	Screw connection
Supply voltage range	19.2 V DC ... 30 V DC
Current input signal	4 mA ... 20 mA
Output signal current	2x 4 mA ... 20 mA
Ambient temperature (operation)	-10 °C ... 60 °C
Width	6.2 mm

Type	Item No.
MINI MCR-BL-I-2I	2810829

## ESSENTIAL edition, Repeater power supply, Input signal Current, Output signal Current



Technical data	
Number of channels	1
Connection method	Screw connection
Supply voltage range	19.2 V DC ... 30 V DC
Current input signal	0 mA ... 20 mA / 4 mA ... 20 mA
Transmitter supply voltage	U <sub>B</sub> - max. 4.5 V for load 0 mA ... 20 mA
Output signal current	0 mA ... 20 mA / 4 mA ... 20 mA
Ambient temperature (operation)	-10 °C ... 60 °C
Width	6.2 mm

Type	Item No.
MINI MCR-BL-RPS-I-I	2810476

## ESSENTIAL edition, Temperature transmitter, Input loop-powered



Technical data	
Number of channels	1
Connection method	Screw connection
Delivery state	Not configured
Available input sources	Resistance thermometer: Pt 100 (IEC 60751/EN 60751)
Supply voltage range	12 V DC ... 30 V DC
Feed-in	Input loop-powered
Output signal current	4 mA ... 20 mA
Ambient temperature (operation)	-10 °C ... 60 °C
Width	6.2 mm

Type	Item No.
MINI MCR-BL-PT100-I-LP-NC	2810609

ESSENTIAL edition, Temperature transmitter



Technical data	
Number of channels	1
Connection method	Screw connection
Delivery state	Not configured
Available input sources	Resistance thermometer: Pt 100 (IEC 60751/EN 60751)
Supply voltage range	19.2 V DC ... 30 V DC
Output signal current	0 mA ... 20 mA / 4 mA ... 20 mA
Ambient temperature (operation)	-10 °C ... 60 °C
Width	6.2 mm

Type	Item No.
MINI MCR-BL-PT100-I-NC	2810489

ESSENTIAL edition, Signal conditioner, Input signal Current and Voltage, Output signal Current and Voltage



Technical data	
Number of channels	1
Connection method	Screw connection
Delivery state	Standard configuration
Supply voltage range	19.2 V DC ... 30 V DC (The DIN rail connector (ME 6,2 TBUS-2 1,5/
Current input signal	0 mA ... 20 mA / 4 mA ... 20 mA
Voltage input signal	0 V ... 10 V / 0 V ... 5 V
Output signal current	0 mA ... 20 mA / 4 mA ... 20 mA
Output signal voltage	0 V ... 10 V / 0 V ... 5 V
Ambient temperature (operation)	-10 °C ... 60 °C
Width	6.2 mm

Type	Item No.
MINI MCR-BL-UI-UI	1070346

ESSENTIAL edition, Signal conditioner, Input signal Current, Output signal Current



Technical data	
Number of channels	1
Connection method	Screw connection
Supply voltage range	19.2 V DC ... 30 V DC
Current input signal	0 mA ... 20 mA / 4 mA ... 20 mA
Output signal current	0 mA ... 20 mA / 4 mA ... 20 mA
Ambient temperature (operation)	-10 °C ... 60 °C
Width	6.2 mm

Type	Item No.
MINI MCR-BL-I-I	2810463

ESSENTIAL edition, Signal conditioner, Input signal Voltage, Output signal Current



Technical data	
Number of channels	1
Connection method	Screw connection
Supply voltage range	19.2 V DC ... 30 V DC
Voltage input signal	0 V ... 10 V
Output signal current	4 mA ... 20 mA
Ambient temperature (operation)	-10 °C ... 60 °C
Width	6.2 mm

Type	Item No.
MINI MCR-BL-U-I-4	2810492

# Safety relay modules and sensors

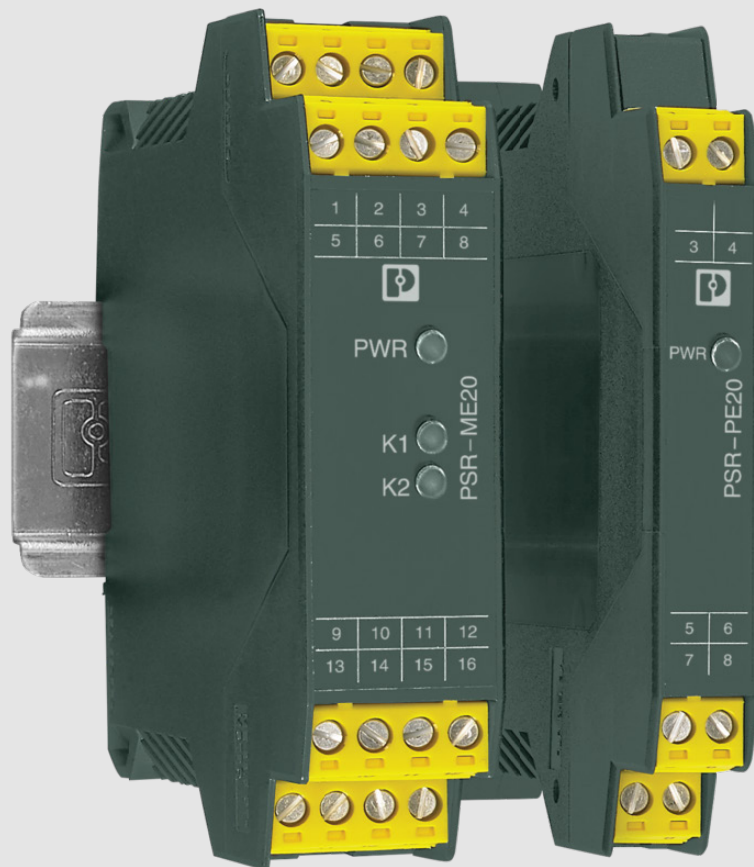

## Safety relay modules and sensors

You can use our safety relays to realize reliable safety functions in machines and systems. You can monitor signals from emergency switching off buttons, light grids, and safety door switches, and initiate a safe state when necessary. The ESSENTIAL edition product range includes safety relays for machine building and safe coupling relays for the process industry.

## Product range overview

---

Safety relays ESSENTIAL edition	<b>73</b>
Safe coupling relays ESSENTIAL edition	<b>74</b>

---

Certified safety technology



You can protect your machines and systems reliably with our ESSENTIAL edition safety relays. The ESSENTIAL edition safety relays cover all safety-related basic functions for use in machine building and in the process industry.

The PSR-ME20 safety relay is suitable for monitoring various safety functions, such as emergency switching off functions, light grids, and safety doors. In addition, the PSR-ME30 and PSR-ME40 contact extensions are available with instantaneous or delayed enabling paths. Use our safe coupling relays PSR-PE20 and PSR-PE60 for emergency-shutdown applications as well as for electrical isolation and power adjustment in the processing environment.

All ESSENTIAL edition safety relays are TÜV-certified and safeguard your machines and systems in accordance with applicable safety regulations up to SIL 2/SIL 3.



#### Several functions in just one device

Our PSR-ME20 safety relay for machine building is multifunctional in use. The device can reliably monitor signals from emergency switching off buttons, light grids, and safety door switches, and can initiate a safe state when necessary. The safety relay is ideally suited for flexible applications with just a few safety functions.



#### For universal use

The ESSENTIAL edition safety relays are TÜV-certified and have all necessary international approvals for use anywhere in the world.

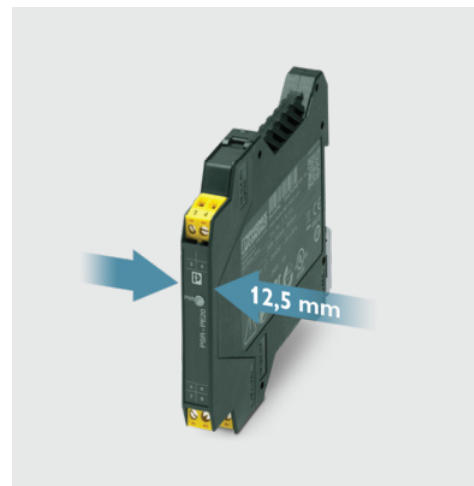

#### Space saving with a compact design

With a small housing width of just 12.5 mm, our safe coupling relays PSR-PE20 and PSRPE60 are particularly space-saving. The device is suitable for low-demand applications in the processing environment. It has an internal 1oo3 structure and can implement emergency shutdowns up to SIL 3.

#### Your advantages:

- Approvals for all global markets
- Safe use in machine building up to PL d in accordance with EN ISO 13849-1 and SIL 2 in accordance with IEC 62061
- Safe use in the processing environment up to SIL 3 in accordance with IEC 61508, IEC 61511, and IEC 50156

Safety relays ESSENTIAL edition



Our PSR-ME20 safety relay for machine building is multifunctional in use. The device can reliably monitor signals from emergency switching off buttons, light grids, and safety door switches, and can initiate a safe state when necessary. In addition, the PSR-ME30 and PSR-ME40 contact extensions are available with instantaneous or delayed enabling paths.

PSRclassic, Safety relays

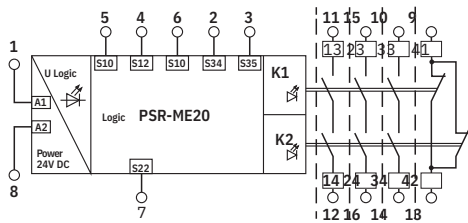

Common technical data	
Approvals Application	Emergency stop Safety door Light grid Automatic start manual, monitored start Screw connection 3
Function	enabling current paths 2 NC parallel EN ISO 13849, Category 3 EN ISO
Connection method	13849, Performance Level d IEC
Contact switching type	61508 - High demand, SIL 2 20.4 V ... 26.4 V 24 V DC 70 mA -20 °C ...
Category	55 °C (observe derating) 22.5 mm
Input voltage range	Rated control
supply voltage	Rated control
supply current	Ambient
temperature (operation)	Width

Type	Item No.
PSR-ME20-3NO-1NC-24DC-SC	1301402

PSRclassic, Safety relays

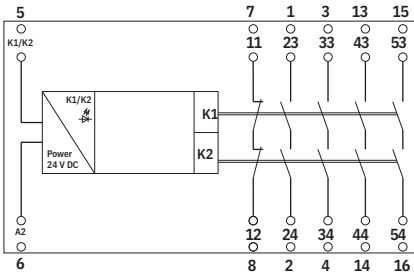

Common technical data	
Approvals	Extension module
Application	Screw connection
Connection method	4 enabling current paths 2 N/C contacts in series
Contact switching type	EN ISO 13849, Category 3 EN ISO 13849, Performance Level d IEC 61508 - High demand, SIL 2
Category	20.4 V ... 26.4 V -20 °C ... 55 °C (observe derating) 22.5 mm
Input voltage range	
Ambient temperature (operation)	
Width	

Type	Item No.
PSR-ME30-4NO-1NC-24DC-SC	1397656

PSRclassic, Safety relays

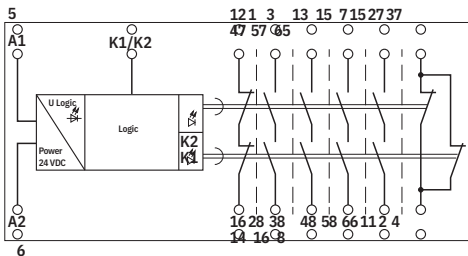

Common technical data	
Approvals	Extension module
Application	With time function
Function	Screw connection
Connection method	4 enabling current paths 2 N/C contacts in series
Contact switching type	EN ISO 13849, Category 3 EN ISO 13849, Performance Level d IEC 61508 - High demand, SIL 2
Category	20.4 V ... 26.4 V 24 V DC 77 mA -20 °C ... 55 °C (observe derating) 22.5 mm
Input voltage range	
Rated control supply voltage	
Rated control supply current	
Ambient temperature (operation)	
Width	

Type	Item No.
PSR-ME40-4NO-2NC-24DC-SC	1397654

**Safe coupling relays ESSENTIAL edition**



With a small housing width of just 12.5 mm, our safe coupling relays PSR-PE20 and PSR-PE60 are particularly space-saving. The device is suitable for low-demand applications in the processing environment. It has an internal 1o3 structure and can implement emergency shutdowns up to SIL 3.

**PSRclassic, Coupling relay**

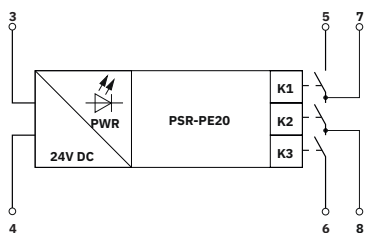

Common technical data	
Application	Safe switch off Low demand
Function	Test pulse filter Forcibly guided contacts
Connection method	Screw connection
Switching voltage	1 enabling current path min. 12 V DC max. 250 V AC/DC (Observe the load curve)
Rated control supply voltage (DC)	21.6 V DC ... 26.4 V DC
Rated control supply current (DC)	24 V DC -10 % ... +10 %
Ambient temperature (operation)	40 mA -40 °C ... 70 °C (observe derating)
Width	12.5 mm

Type	Item No.
PSR-PE20-1NO-24DC-SC	1119573

**PSRclassic, Coupling relay**

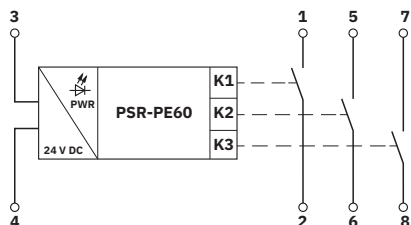

Common technical data	
Application	Safe switch off Safe switch on High demand Low demand
Function	Test pulse filter
Connection method	Screw connection
Contact switching type	3 enabling current paths
Switching voltage	min. 12 V DC max. 250 V AC/DC
Rated control supply voltage (DC)	24 V DC -10 % ... +10 % ("1" signal)
Rated control supply current	typ. 31 mA
Ambient temperature (operation)	-40 °C ... 70 °C (observe derating)
Width	12.5 mm

Type	Item No.
PSR-PE60-3NO-24DC-SC	1436353

# Relays and optocouplers

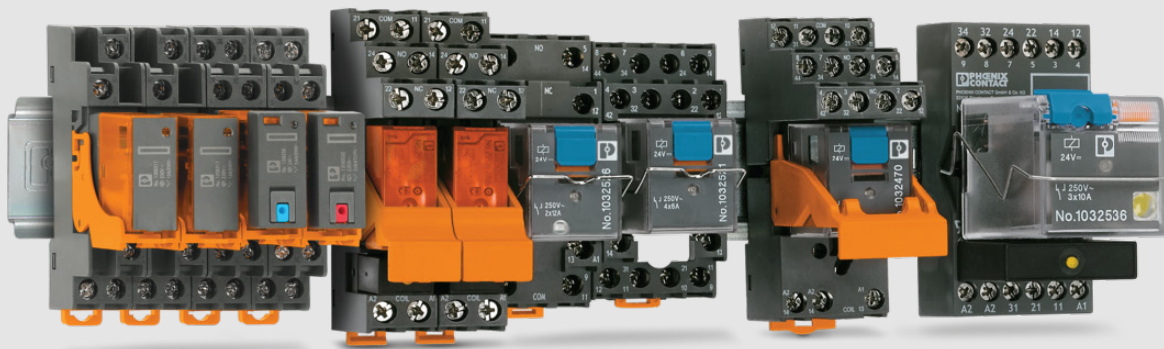

## Relays and optocouplers

In industrial applications, electromechanical and solid-state relays perform the important tasks of switching, isolating, amplifying, measuring, and monitoring between the control system and devices in the field.

The ESSENTIAL edition product family from Phoenix Contact includes control relays, timer relays, and monitoring relays for the diagnosis of various electrical variables. This allows you to flexibly construct different relay solutions according to on-site needs.<br/>

## Product range overview

---

### Coupling relays

Industrial relay system with basic functionality ESSENTIAL edition	<b>81</b>
---	-----------

---

Timer relays ESSENTIAL edition	<b>93</b>
--------------------------------	-----------

---

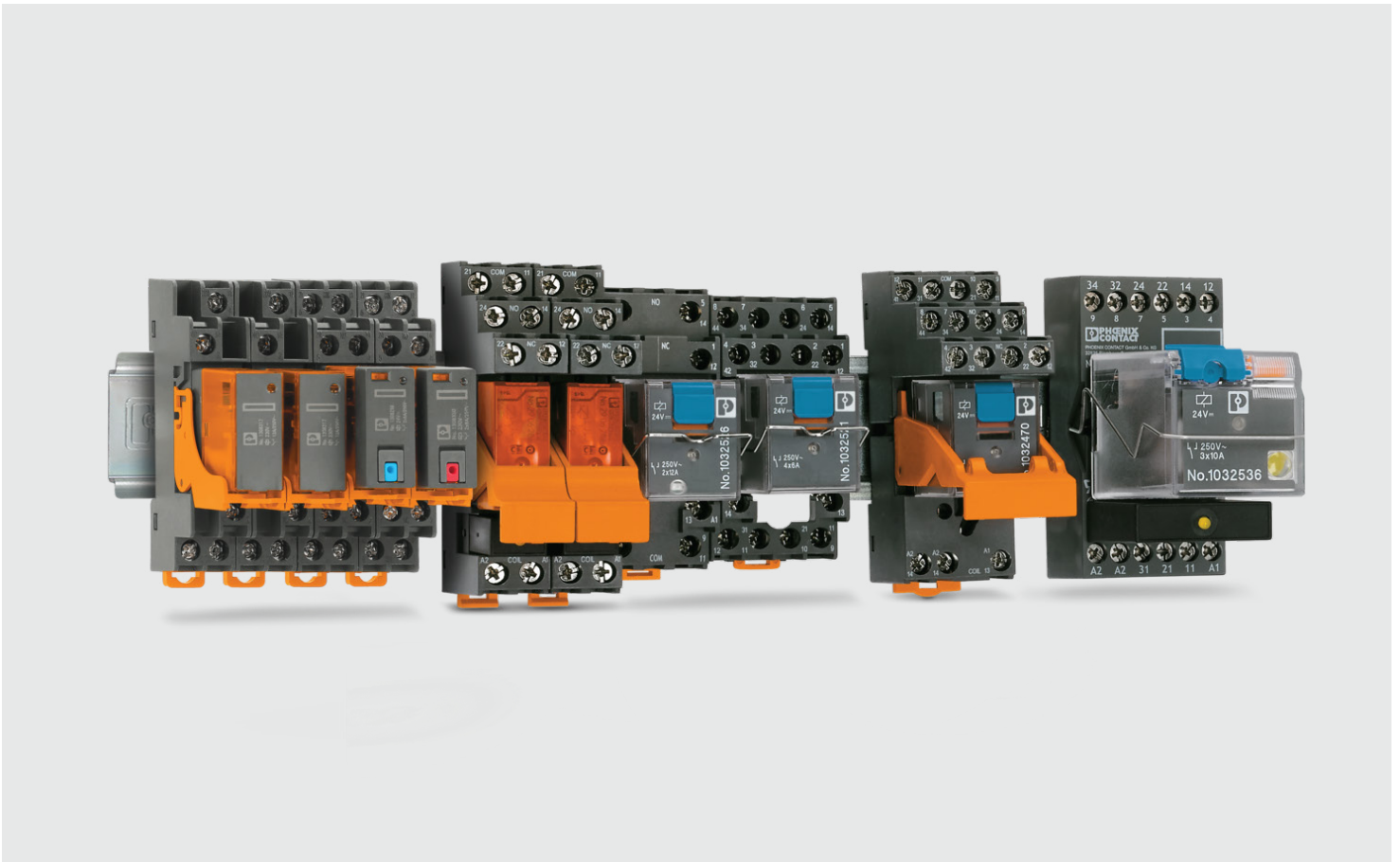

ESSENTIAL edition is an efficient, modular industrial relay system with basic functions, consisting of relays, relay bases, retaining brackets, and plug-in function modules. Take advantage of a flexible range with one to four changeover contacts and input voltages of 12 V DC to 230 V AC.

From product development to series production – the high quality of Phoenix Contact products is ensured through consistent testing in accordance with uniform directives and company standards.



### ECOR-1

The 16 mm narrow ECOR-1 base series with screw connection is suitable for miniature power relays and miniature switching relays with one or two changeover contacts. Currents up to 12 A can be switched. Relay bases are available with a bolt connection.



### ECOR-2

The ECOR-2 base series is suitable for industrial relays with two or four changeover contacts. Currents up to 12 A are no problem for these bases. Relay bases are available either with screw connection or bolt connection. In addition, a width-optimized ECOR-2 base with plugging capabilities for input / interference suppression modules is available for industrial relays with two changeover contacts.



### ECOR-4

The 44 mm wide ECOR-4 base series is ideal for power relays with four FASTON contacts. Switching currents up to 10 A can be implemented here. The relay bases are available as a bolt connection with screw connection input/interference suppression modules.



### 100 % tested

Securing high product quality with 100 % testing of isolation and function.

Additional type tests:

- Dielectric test
- Function test

The following type tests are also performed:

- Conductor pull-out test
- Dielectric test
- Temperature increase test

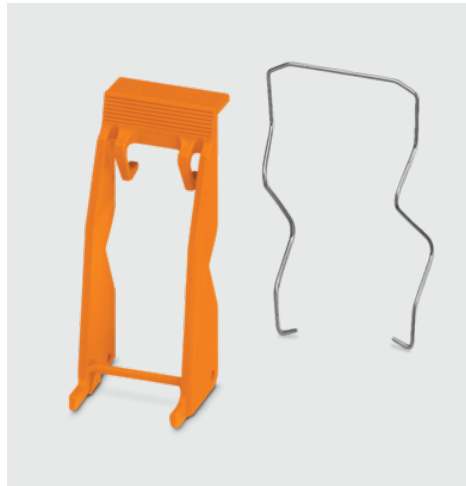

### Reliable system for high machine and system availability

Plastic relay retaining bracket with eject function and metal relay retaining bracket



### Plug-in modules

Function plug-in modules for coil suppression and status display.



### ECOR-1 FASTON relay

With the ECOR-1 FASTON relay in 1CO & 2CO contact switching type available with or without manual actuation in various voltage versions, Phoenix Contact offers solutions for industrial areas that require robustness and a space-saving design.

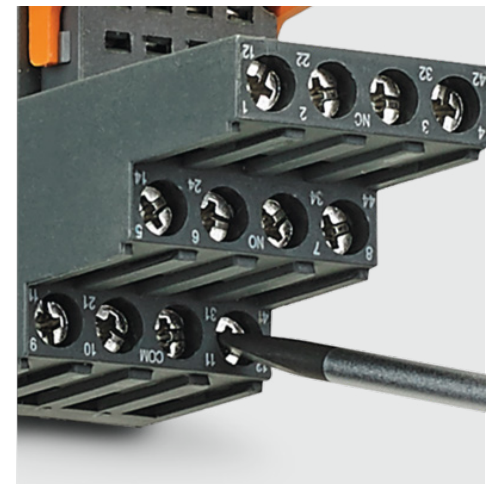

### Easy wiring

Easy wiring with screw connection. Also with ferrules or bold connection available.

### Your advantages:

- High cost efficiency
- Relays from 1 to 4 changeover contacts
- Robust bolt connection technology
- UL and CSA approval

## Time and monitoring relays

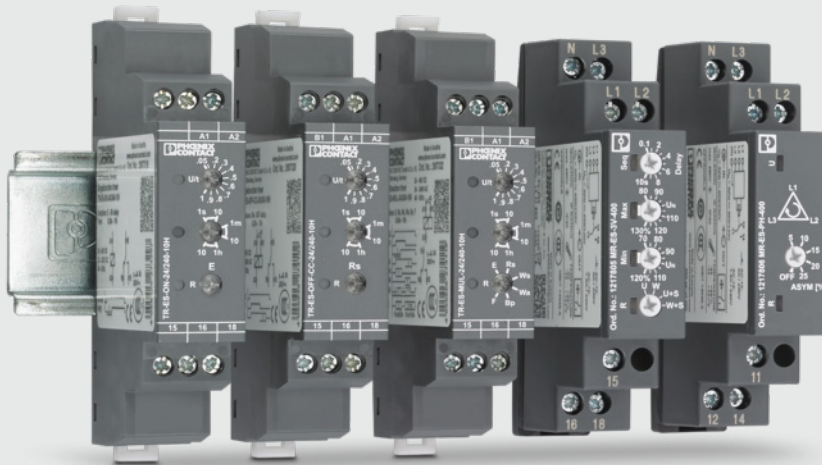

Compact timer relays in a 17.5 mm wide housing for controlling time sequences. Single-function timer relays, multi-functional timer relays, and monitoring relays are suitable for most universal requirements. The ESSENTIAL edition timer relays can be used as an efficient application for many time delay tasks. The ESSENTIAL edition monitoring relays quickly recognize deviations from key system parameters. They report these deviations or shut system parts down selectively.

### Your advantages:

- Easy to select, thanks to just 3 articles which can satisfy most universal time delay tasks
- Optimum time control with setting range from milliseconds to 10 hours
- Monitoring relay ideally suited for simple monitoring tasks
- Easy handling, as time parameters can be adjusted conveniently on the front of the housing
- Space saving, thanks to a compact housing
- CCC approval



### Find the right product quickly

With switch-on delay, switch-off delay or multifunctional: available in just three versions, they cover all applications associated with conventional time control.



### Space-saving

Thanks to the compact installation housing, they are ideally suited for building installation. As reasonably priced solutions with numerous functions, the products are just as ideally suited for series production.

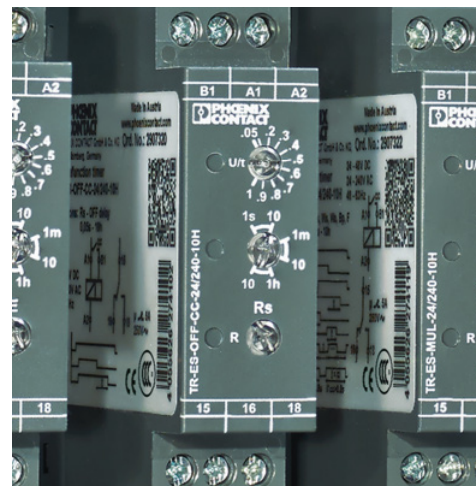

### Simple operation

Parameters can be set conveniently via the rotary switch on the front of the housing. The timer relays feature a precise setting range of milliseconds to up to 10 hours.



### Three-phase voltage monitoring relays

The ESSENTIAL edition MR-ES series voltage monitoring relays can detect grid and voltage failures early enough to safeguard the reliable operation of devices and systems. You can select between two device types: Voltage or phase monitoring.

## Coupling relays

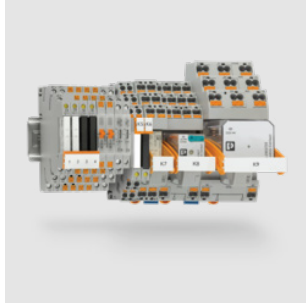

Coupling relays are an indispensable part of industrial automation, where reliability, safety, and efficiency are of great importance. Rely on our wide range of solid-state relays and electromechanical relays, available as plug-in versions or as complete modules. Coupling relays, force-guided coupling relays, highly compact relay modules, and relays for the Ex area also help achieve high system availability in your application.

### Industrial relay system with basic functionality ESSENTIAL edition

With ESSENTIAL edition industrial relays from Phoenix Contact, various relay solutions can be constructed flexibly according to on-site needs.



### ESSENTIAL edition, Relay base, ECOR-1



Technical data	
Input voltage	250 V AC/DC
Nominal current	12 A
Connection method	Screw connection
Ambient temperature (operation)	-25 °C ... 70 °C
Width	15.7 mm
Height	79.2 mm
Depth	69 mm (ECOR-RH-1L)

Type	Item No.
ECOR-1-BSC3/2X21	<a href="#">2907518</a>

Accessories	Type	Item No.
ESSENTIAL edition, Relay retaining bracket, Plastic	ECOR-RH-1L	<a href="#">2907524</a>
ESSENTIAL edition, Plug-in module for relay bases, Protective circuit Freewheeling diode, LED	LDP- 12- 24DC	<a href="#">2833657</a>
ESSENTIAL edition, Plug-in module for relay bases, Protective circuit Freewheeling diode, LED	LDP- 12- 24DC	<a href="#">2833657</a>
ESSENTIAL edition, Plug-in module for relay bases, Protective circuit Freewheeling diode	DP-12-220 DC	<a href="#">2907517</a>
ESSENTIAL edition, Plug-in module for relay bases, Protective circuit Varistor, LED	LV-120-230AC/110DC	<a href="#">2833738</a>
ESSENTIAL edition, Plug-in module for relay bases, Protective circuit Varistor	V-120-230UC	<a href="#">2833880</a>
ESSENTIAL edition, Plug-in module for relay bases, Protective circuit RC element	RC-120-230UC	<a href="#">2833767</a>

### ESSENTIAL edition, Relay base, ECOR-1

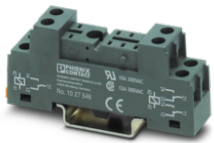

Technical data	
Input voltage	≤ 230 V AC/DC
Nominal current	10 A
Connection method	Bolt connection
Ambient temperature (operation)	-25 °C ... 55 °C
Width	15.8 mm
Height	71.5 mm
Depth	58.1 mm (with retaining bracket)

Type	Item No.
ECOR-1-BSC2-RT/2X21	<a href="#">1027546</a>

Accessories	Type	Item No.
ESSENTIAL edition, Relay retaining bracket, Plastic	ECOR-RH-1L	<a href="#">2907524</a>

Single relay, Miniature relay, 1 changeover contact, 12 V DC



Common technical data	
Response time	8 ms
Release time	6 ms
Contact switching type	1 changeover contact
Contact material	AgNi
Maximum switching voltage	250 V AC/DC
Minimum switching voltage	5 V (At 24 mA)
Limiting continuous current	16 A
Switching current	≥ 10 mA (at 12 V)
Inrush current	≤ 30 A (300 ms)
Standards/regulations	IEC 60664 EN 61810-1
Ambient temperature (operation)	-40 °C ... 85 °C
Width	12.7 mm
Height	29 mm
Depth	15.7 mm

Input voltage	Type	Item No.
12 V DC 24 V	REL-MR-BL- 12DC/21HC	1109537
DC	REL-MR-BL- 24DC/21HC	2906285

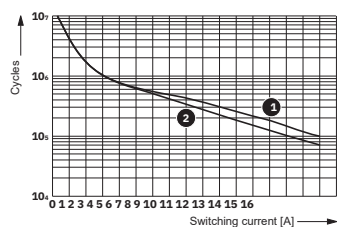

- 1 12 250 V AC, ohmic load (DC coils)
- 2 250 V AC, ohmic load (AC coils)

Electrical service life

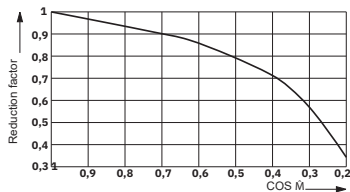

Service life reduction factor with various cos phi

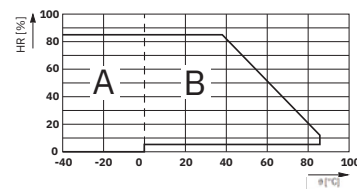

Permissible humidity for operation and storage. The maximum permissible ambient temperature as specified in the data sheet must be observed.

Area A: Ice buildup at ambient temperatures ≤ 0°C must be prevented Area B: Condensation at ambient temperatures > 0°C must be prevented

On 30 full days that are naturally distributed across an entire year, a humidity level of 95% is permissible at an ambient temperature ≤ 25°C.

Single relay, Miniature relay, 1 changeover contact, 24 V AC



Common technical data	
Response time range	3 ms ... 12 ms (depending on phase relation)
Release time range	2 ms ... 9 ms (depending on phase relation)
Contact switching type	1 changeover contact
Contact material	AgNi
Maximum switching voltage	250 V AC/DC
Minimum switching voltage	5 V (At 24 mA)
Limiting continuous current	16 A
Switching current	≥ 10 mA (at 12 V)
Inrush current	≤ 30 A (300 ms)
Standards/regulations	IEC 60664 EN 61810-1
Ambient temperature (operation)	-40 °C ... 70 °C
Width	12.7 mm
Height	29 mm
Depth	15.7 mm

Input voltage	Type	Item No.
24 V AC	REL-MR-BL- 24AC/21HC	1109540
115 V AC	REL-MR-BL-115AC/21HC	1109542
230 V AC	REL-MR-BL-230AC/21HC	2906288

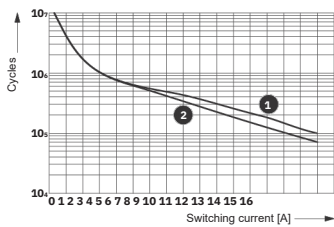

- 1 12.250 V AC, ohmic load (DC coils)
- 2 250 V AC, ohmic load (AC coils)

Electrical service life

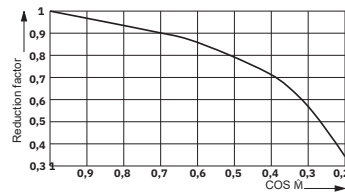

Service life reduction factor with various cos phi

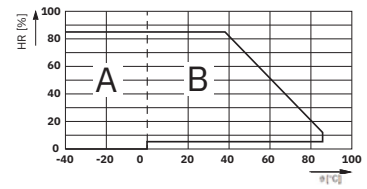

Permissible humidity for operation and storage. The maximum permissible ambient temperature as specified in the data sheet must be observed.

Area A: Ice buildup at ambient temperatures ≤ 0°C must be prevented Area B: Condensation at ambient temperatures > 0°C must be prevented

On 30 full days that are naturally distributed across an entire year, a humidity level of 95% is permissible at an ambient temperature ≤ 25°C.

### Single relay, Miniature relay, 2 changeover contacts, 12 V DC



Common technical data	
Response time	8 ms
Release time	6 ms
Contact switching type	2 changeover contacts
Contact material	AgNi
Maximum switching voltage	250 V AC/DC
Minimum switching voltage	5 V (at 10 mA)
Limiting continuous current	8 A
Switching current	≥ 10 mA (At 5 V)
Inrush current	≤ 12 A (20 ms)
Standards/regulations	IEC 60664 EN 61810-1
Ambient temperature (operation)	-40 °C ... 85 °C
Width	12.7 mm
Height	29 mm
Depth	15.7 mm

Input voltage	Type	Item No.
12 V DC	REL-MR-BL- 12DC/21-21	1109543
24 V DC	REL-MR-BL- 24DC/21-21	2906286
48 V DC	REL-MR-BL- 48DC/21-21	1109544
110 V DC	REL-MR-BL-110DC/21-21	1109545

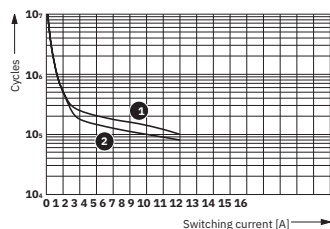

- 1 250 V AC, ohmic load (DC coils)
- 2 250 V AC, ohmic load (AC coils)

Electrical service life

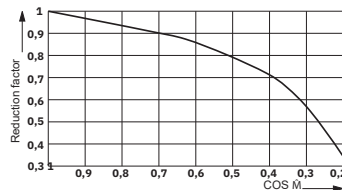

Service life reduction factor with various cos phi

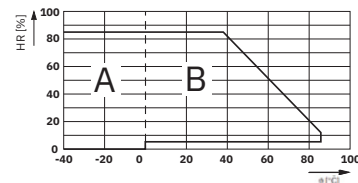

Permissible humidity for operation and storage. The maximum permissible ambient temperature as specified in the data sheet must be observed.

Area A: Ice buildup at ambient temperatures ≤ 0°C must be prevented  
 Area B: Condensation at ambient temperatures > 0°C must be prevented

On 30 full days that are naturally distributed across an entire year, a humidity level of 95% is permissible at an ambient temperature ≤ 25°C.

Single relay, Miniature relay, 2 changeover contacts, 24 V AC



Common technical data	
Response time range	3 ms ... 12 ms (depending on phase relation)
Release time range	2 ms ... 9 ms (depending on phase relation)
Contact switching type	2 changeover contacts
Contact material	AgNi
Maximum switching voltage	250 V AC/DC
Minimum switching voltage	5 V (at 10 mA)
Limiting continuous current	8 A
Switching current	≥ 10 mA (At 5 V)
Inrush current	≤ 12 A (20 ms)
Standards/regulations	IEC 60664 EN 61810-1
Ambient temperature (operation)	-40 °C ... 70 °C
Width	12.7 mm
Height	29 mm
Depth	15.7 mm

Input voltage	Type	Item No.
24 V AC	REL-MR-BL- 24AC/21-21	1109546
115 V AC	REL-MR-BL-115AC/21-21	1109569
230 V AC	REL-MR-BL-230AC/21-21	2906287

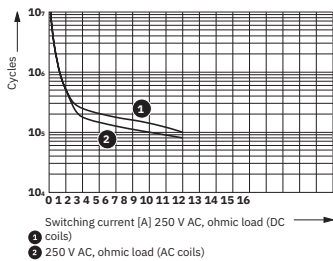

Electrical service life

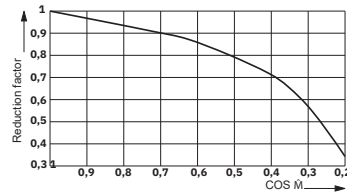

Service life reduction factor with various cos phi

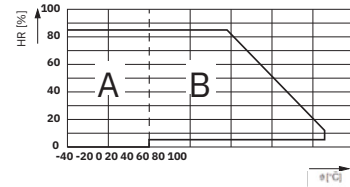

Permissible humidity for operation and storage. The maximum permissible ambient temperature as specified in the data sheet must be observed.

Area A: Ice buildup at ambient temperatures ≤ 0°C must be prevented Area B: Condensation at ambient temperatures > 0°C must be prevented

On 30 full days that are naturally distributed across an entire year, a humidity level of 95% is permissible at an ambient temperature ≤ 25°C.

ESSENTIAL edition, Relay retaining bracket



Technical data	
Lead content (EU RoHS)_GRP	Lead-free (Pb < 0.1 %)

Type	Item No.
ECOR-RH-1H	2907523

ESSENTIAL edition, Relay retaining bracket, Plastic



Technical data	
Lead content (EU RoHS)_GRP	Lead-free (Pb < 0.1 %)
Material	Plastic

Type	Item No.
ECOR-RH-1L	2907524

ESSENTIAL edition, Relay base, ECOR-2



Technical data	
Input voltage	250 V AC/DC
Nominal current	12 A
Connection method	Bolt connection
Ambient temperature (operation)	-25 °C ... 55 °C
Width	25 mm
Height	68.5 mm
Depth	63 mm (ECOR-RHM-2)

Type	Item No.
ECOR-2-BSC2-RT/2X21	2908341

Accessories	Type	Item No.
ESSENTIAL edition, Relay retaining bracket, Plastic	ECOR-RH-2L	1051972

ESSENTIAL edition, Single relay, Industrial relay, compact, 2 changeover contacts, 24 V AC



Common technical data	
Response time range	5 ms ... 15 ms
Release time range	5 ms ... 20 ms
Contact switching type	2 changeover contacts
Contact material	AgNi
Maximum switching voltage	250 V AC/DC
Minimum switching voltage	12 V (10 mA)
Limiting continuous current	12 A
Switching current	≥ 10 mA (12 V)
Inrush current	≤ 24 A (20 ms, N/O contacts)
Standards/regulations	EN 61810-1
Ambient temperature (operation)	-40 °C ... 70 °C

Input voltage	Width	Height	Depth	Type	Item No.
24 V AC	22.5 mm	28 mm	35.5 mm	REL-IR-BL/L- 24AC/2X21	1109555
115 V AC	22.5 mm	28 mm	35.5 mm	REL-IR-BL/L-115AC/2X21	1109556
230 V AC	22.5 mm	28 mm	35.5 mm	REL-IR-BL/L-230AC/2X21	1032530
230 V AC				REL-IR-BL-230AC/2X21	1032528

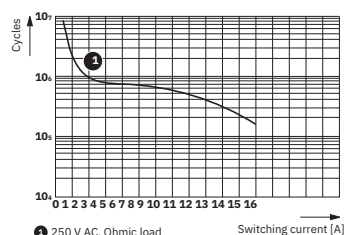

Electrical service life

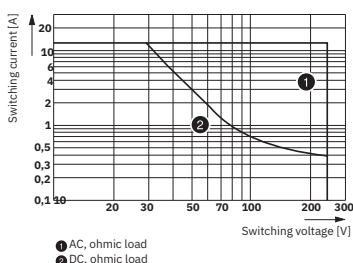

Interrupting rating

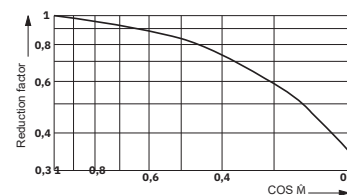

Service life reduction factor

**ESSENTIAL edition, Single relay, Industrial relay, compact, 2 changeover contacts, 12 V DC**



Common technical data	
Response time	15 ms
Release time	10 ms
Contact switching type	2 changeover contacts
Contact material	AgNi
Maximum switching voltage	250 V AC/DC
Minimum switching voltage	12 V (10 mA)
Limiting continuous current	12 A
Switching current	≥ 10 mA (12 V)
Inrush current	≤ 24 A (20 ms, N/O contacts)
Standards/regulations	EN 61810-1
Ambient temperature (operation)	-40 °C ... 70 °C

Input voltage	Width	Height	Depth	Type	Item No.
12 V DC	22.5 mm	28 mm	35.5 mm	REL-IR-BL/L- 12DC/2X21	1109547
24 V DC				REL-IR-BL- 24DC/2X21	1032470
24 V DC	22.5 mm	28 mm	35.5 mm	REL-IR-BL/L- 24DC/2X21	1032526
48 V DC	22.5 mm	28 mm	35.5 mm	REL-IR-BL/L- 48DC/2X21	1109548
110 V DC	22.5 mm	28 mm	35.5 mm	REL-IR-BL/L-110DC/2X21	1109550
125 V DC	22.5 mm	28 mm	35.5 mm	REL-IR-BL/L-125DC/2X21	1109553
220 V DC	22.5 mm	28 mm	35.5 mm	REL-IR-BL/L-220DC/2X21	1109554

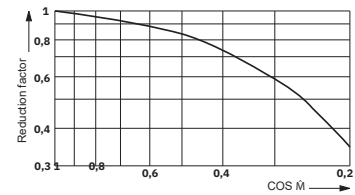
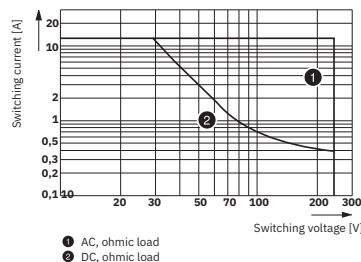
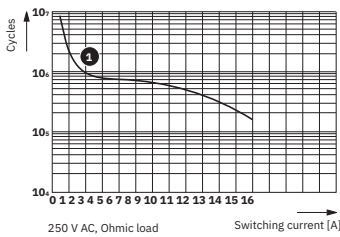

Electrical service life

**ESSENTIAL edition, Relay base, ECOR-2**



Technical data	
Input voltage	300V AC/DC
Nominal current	12A
Connection method	Screw connection
Ambient temperature (operation)	-25°C ... 85 °C
Width	27mm
Height	78.5mm
Depth	86mm (ECOR-RH-2)

Type	Item No.
ECOR-2-BSC3/4X21	2907521

Accessories	Type	Item No.
ESSENTIAL edition, Relay retaining bracket, Plastic	ECOR-RH-2L	1051972
ESSENTIAL edition, Plug-in module for relay bases, Protective circuit Freewheeling diode, LED	LDP- 12- 24DC	2833657
ESSENTIAL edition, Plug-in module for relay bases, Protective circuit Freewheeling diode	DP-12-220 DC	2907517
ESSENTIAL edition, Plug-in module for relay bases, Protective circuit Varistor, LED	LV-120-230AC/110DC	2833738
ESSENTIAL edition, Plug-in module for relay bases, Protective circuit Varistor	V-120-230UC	2833880
ESSENTIAL edition, Plug-in module for relay bases, Protective circuit RC element	RC-120-230UC	2833767

**ESSENTIAL edition, Relay base, ECOR-2**



Technical data	
Input voltage	250 V AC/DC
Nominal current	5 A
Connection method	Bolt connection
Ambient temperature (operation)	-25 °C ... 55 °C
Width	29.8 mm
Height	64.9 mm
Depth	63 mm (ECOR-RHM-2)

Type	Item No.
ECOR-2-BSC2-RT/4X21	2908214

Accessories	Type	Item No.
ESSENTIAL edition, Relay retaining bracket, Plastic	ECOR-RH-2L	1051972

ESSENTIAL edition, Relay base, ECOR-2



Technical data	
Input voltage	≤ 230 V AC/DC
Connection method	Screw connection
Ambient temperature (operation)	-25 °C ... 70 °C
Width	27 mm
Height	75 mm
Depth	84 mm (with retaining bracket)

Type	Item No.
ECOR-2-BSC2/4X21	1089994

ESSENTIAL edition, Single relay, Industrial relay, compact, 4 changeover contacts, 12 V DC



Common technical data	
Response time	15 ms
Release time	10 ms
Contact switching type	4 changeover contacts
Contact material	AgNi
Maximum switching voltage	250 V AC/DC
Minimum switching voltage	12 V (10 mA)
Limiting continuous current	6 A
Switching current	≥ 10 mA (12 V)
Inrush current	≤ 12 A (20 ms, N/O contacts)
Standards/regulations	EN 61810-1
Ambient temperature (operation)	-40 °C ... 70 °C

Input voltage	Width	Height	Depth	Type	Item No.
12 V DC	22.5 mm	28 mm	35.5 mm	REL-IR-BL/L- 12DC/4X21	1109557
24 V DC				REL-IR-BL- 24DC/4X21	1032521
24 V DC	22.5 mm	28 mm	35.5 mm	REL-IR-BL/L- 24DC/4X21	1032527
48 V DC	22.5 mm	28 mm	35.5 mm	REL-IR-BL/L- 48DC/4X21	1109558
110 V DC	22.5 mm	28 mm	35.5 mm	REL-IR-BL/L-110DC/4X21	1109560
125 V DC	22.5 mm	28 mm	35.5 mm	REL-IR-BL/L-125DC/4X21	1109561
220 V DC	22.5 mm	28 mm	35.5 mm	REL-IR-BL/L-220DC/4X21	1109562

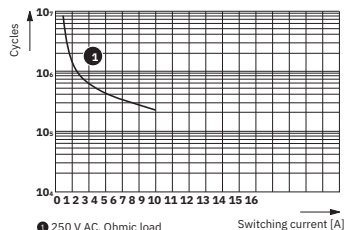

Electrical service life

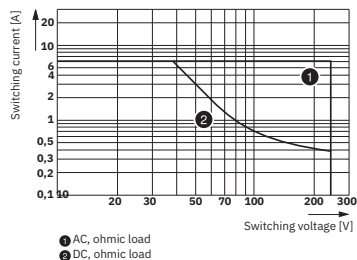

Interrupting rating

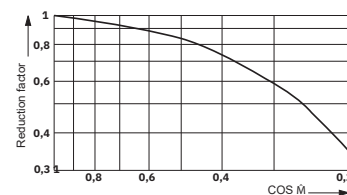

Service life reduction factor

**ESSENTIAL edition, Single relay, Industrial relay, compact, 4 changeover contacts, 24 V AC**



Common technical data	
Response time range	5 ms ... 15 ms
Release time range	5 ms ... 20 ms
Contact switching type	4 changeover contacts
Contact material	AgNi
Maximum switching voltage	250 V AC/DC
Minimum switching voltage	12 V (10 mA)
Limiting continuous current	6 A
Switching current	≥ 10 mA (12 V)
Inrush current	≤ 12 A (20 ms, N/O contacts)
Standards/regulations	EN 61810-1
Ambient temperature (operation)	-40 °C ... 70 °C

Input voltage	Width	Height	Depth	Type	Item No.
24 V AC	22.5 mm	28 mm	35.5 mm	REL-IR-BL/L- 24AC/4X21	1109563
115 V AC	22.5 mm	28 mm	35.5 mm	REL-IR-BL/L-115AC/4X21	1109564
230 V AC	22.5 mm	28 mm	35.5 mm	REL-IR-BL/L-230AC/4X21	1032531
230 V AC	-	-	-	REL-IR-BL-230AC/4X21	1032529

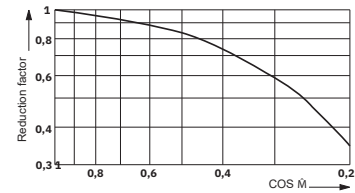
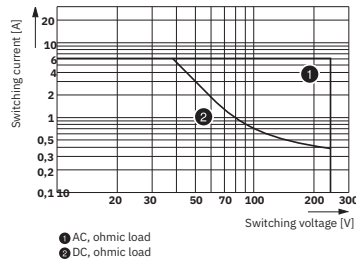
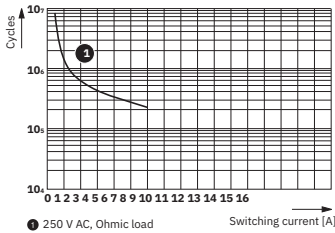

**ESSENTIAL edition, Relay retaining bracket**



Technical data	
Lead content (EU RoHS)_GRP	Lead-free (Pb < 0.1 %)

Type	Item No.
ECOR-RH-2	2907526

**ESSENTIAL edition, Relay retaining bracket, Metal**



Technical data	
Lead content (EU RoHS)_GRP	Lead-free (Pb < 0.1 %)
Material	Metal

Type	Item No.
ECOR-RHM-2	2908533

ESSENTIAL edition, Relay base, ECOR-4



Technical data	
Input voltage	≤ 230 V AC/DC
Connection method	Screw connection
Ambient temperature (operation)	-40 °C ... 85 °C
Width	44.1 mm
Height	83.3 mm
Depth	30 mm

Type	Item No.
ECOR-4-BSC2/4X21	1157947

ESSENTIAL edition, Single relay, Single relay, 4 changeover contacts, 24 V DC



Common technical data	
Contact switching type	4 changeover contacts
Contact material	AgSnO
Maximum switching voltage	250 V AC/DC
Minimum switching voltage	17 V (10 mA)
Limiting continuous current	10 A
Switching current	≥ 10 mA (17 V)
Standards/regulations	EN 61810 IEC 60664
Ambient temperature (operation)	-25 °C ... 55 °C
Width	41.5 mm
Height	28 mm
Depth	36.5 mm

Input voltage	Response time	Release time	Type	Item No.
24 V DC	≤ 20 ms	≤ 20 ms	REL-PR-BL- 24DC/4X21	1157980
110 V DC	≤ 20 ms	≤ 20 ms	REL-PR-BL-110DC/4X21	1157976
125 V DC	≤ 20 ms	≤ 20 ms	REL-PR-BL-125DC/4X21	1157973
220 V DC	≤ 20 ms	≤ 20 ms	REL-PR-BL-220DC/4X21	1157968
115 V AC	≤ 20 ms (depending on phase relation)	≤ 20 ms (depending on phase relation)	REL-PR-BL-115AC/4X21	1157971
230 V AC	≤ 20 ms (depending on phase relation)	≤ 20 ms (depending on phase relation)	REL-PR-BL-230VAC/4X21	1157966

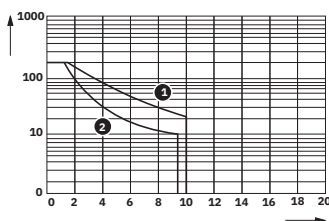

Electrical service life

0 0.2 0.4 0.6 0.8 1.0 1.2 1.4 1.6 1.8 2.0

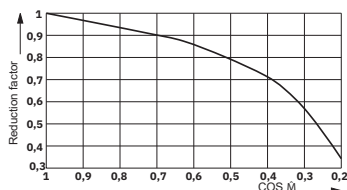

Service life reduction factor

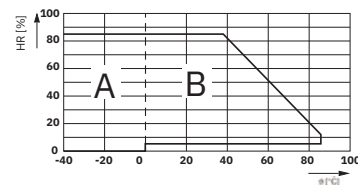

Permissible humidity for operation and storage. The maximum permissible ambient temperature as specified in the data sheet must be observed.

Area A: Ice buildup at ambient temperatures ≤ 0°C must be prevented  
Area B: Condensation at ambient temperatures > 0°C must be prevented

On 30 full days that are naturally distributed across an entire year, a humidity level of 95% is permissible at an ambient temperature ≤ 25°C.

ESSENTIAL edition, Plug-in module for relay bases, Protective circuit Freewheeling diode, LED



Technical data	
Input voltage range	12 V DC ... 24 V DC ±20 % 12 V DC ... 24 V DC

Type	Item No.
LDP- 12-24DC	2833657

**ESSENTIAL edition, Plug-in module for relay bases, Protective circuit Varistor, LED**



Technical data	
Input voltage	110 V DC
Input voltage range	120 V AC ... 230 V AC
	120 V AC ... 230 V AC

Type	Item No.
LV-120-230AC/110DC	2833738

**ESSENTIAL edition, Plug-in module for relay bases, Protective circuit RC element**



Technical data	
Input voltage range	120 V AC/DC ... 230 V AC/DC 120 V AC/DC ... 230 V AC/DC

Type	Item No.
RC-120-230UC	2833767

**ESSENTIAL edition, Plug-in module for relay bases**



Technical data	
Input voltage range	48 V DC ... 60 V DC
	48 V DC ... 60 V DC

Type	Item No.
LDP3- 48-60DC	2833783

**ESSENTIAL edition, Plug-in module for relay bases, Protective circuit Varistor**



Technical data	
Input voltage range	120 V AC/DC ... 230 V AC/DC 120 V AC/DC ... 230 V AC/DC

Type	Item No.
V-120-230UC	2833880

ESSENTIAL edition, Plug-in module for relay bases, Protective circuit Freewheeling diode



Technical data

Input voltage range	12 V DC ... 220 V DC $\pm$ 20 % 12 V DC ... 220 V DC
---------------------	---

Type  
DP-12-220 DC

Item No.  
[2907517](#)

Timer relays ESSENTIAL edition



The ESSENTIAL edition timer relays can be used as an efficient application for many time delay tasks. With switch-on delay, switch-off delay, or multifunctional: available in just three versions, they cover all applications associated with conventional time control.

Timer relay



Technical data	
Nominal input voltage range	24 V DC ... 48 V DC -10 % ... +10 % 24 V AC ... 240 V AC -15 % ... +10 %
Time range	50 ms ... 10 h (6 time end ranges)
Time function	With switch-on delay Rs: Delay release Ws: Pulse output (rising edge) and control contact Wa: Pulse output (falling edge) and control contact Bp: Cycle pulse output (initial status is 0) Switch Wu: Pulse output (rising edge) and voltage control
Contact switching type	1 floating changeover contact
Maximum switching voltage	250 V AC
Standards/regulations	IEC 61812-1
Ambient temperature (operation)	-25 °C ... 50 °C
Width	17.5 mm
Height	98 mm
Depth	57.9 mm
<b>Type</b>	TR-ES-1T-MUL-10H
<b>Item No.</b>	2909777

## Open communication with customers and partners worldwide

Phoenix Contact is a global market leader based in Germany. We are known for producing forward-thinking products and solutions for the comprehensive electrification, networking, and automation of all sectors of the economy and infrastructure. With a global network, we maintain close relationships with our customers, something we believe is essential for our common success.

You can find your local partner at  
[phoenixcontact.com](https://phoenixcontact.com)

