

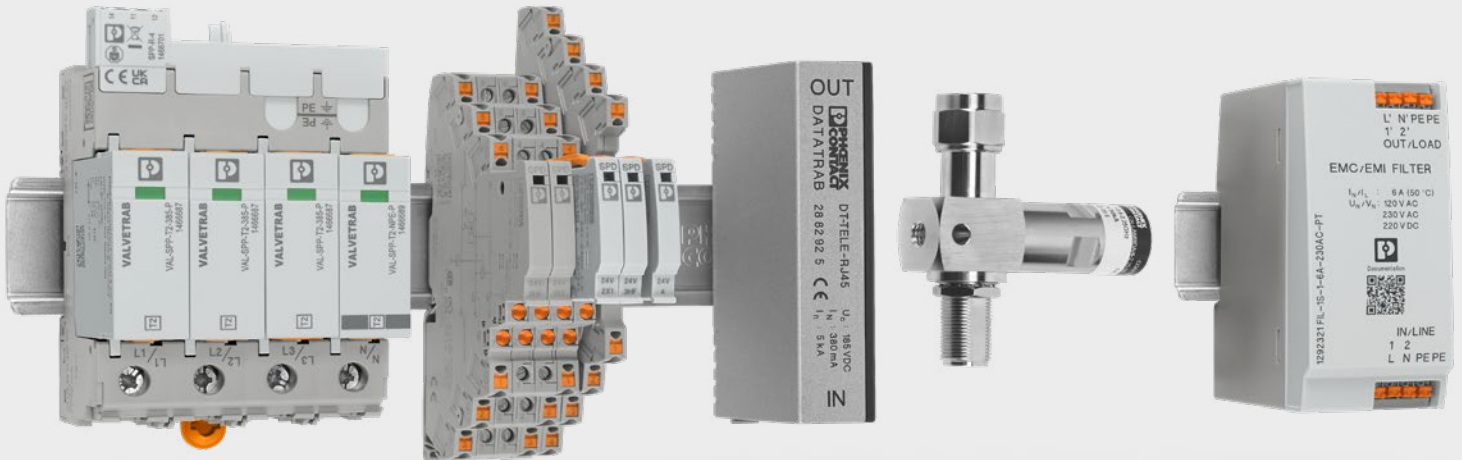

Power Reliability

2026



## Surge protection and EMC filters

Protection for superior system availability

# How does this product brochure work?

The product brochures provide an initial overview of the Phoenix Contact range. They provide support in the preselection of products and make it possible to switch directly to the online shop to obtain more detailed technical information.

You can also compare your product selection in a comparison table on our website. Use the product brochures and our website to find the ideal solution for your requirements.

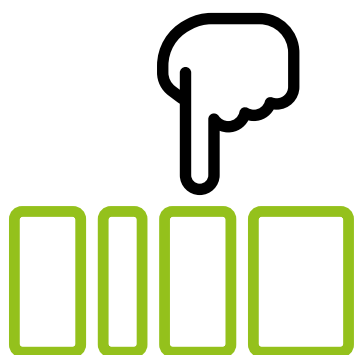

## Selection of the product group

The brochures are divided into different product categories. Each brochure is structured according to the product groups of the respective category. First, the individual groups are compared, and then presented in separate sections.

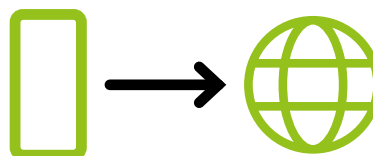

## Product selection and website

Clear information and the most important technical data can be found at a glance within the individual sections. Once you have made a preselection of products, switch directly to the items in our online shop via the item numbers or links.

### Note

In some cases, older product series and color versions can only be found on the Internet. The accessories are also located on the individual product pages on the Internet.



From the product brochure ...

## Overview of product brochures

All product brochures can be found on our website. Simply enter the web code in the search bar or scan the QR code.

 **Web code: #3369**



### Detailed product assessment

A detailed overview of all technical data for your preselected products is available in the online shop. In addition, our website provides more detailed information, suitable accessories, and a product comparison function.



### Order

After selecting the appropriate products, you can add them to your shopping cart and order them. Alternatively, the “Purchase from Distributors” button leads to a list of our distribution partners.

... to our online shop: [phoenixcontact.com](https://www.phoenixcontact.com)

# Protection for superior system availability

## Powerful and reliable

Our products for the operational safety of electrical systems, installations, and devices enable you to effortlessly create an uninterruptible and clean power supply, as well as a stable data connection. With our coordinated product portfolio for surge protection, a protection concept can be created for practically any application.



1

### Surge protection for power supplies

From feed-in through to the end device: Increase the availability of your system with our surge protection.

➤ More information starting on page 8

2

### Surge protection for MCR technology

Powerful protective devices with low voltage protection levels provide optimum protection for your MCR applications.

➤ More information starting on page 48

# 5

## EMC filters

EMC filters protect against high-frequency interference voltages and currents that can be caused by electrical equipment during normal operation and in case of faults. You can use our EMC filters to ensure uninterrupted and safe operation even in environments subject to interference.

➤ More information starting on page 90



# 3

## Surge protection for information technology

Safeguard your data cables. Fast signals require one thing above all else – protection that responds very quickly.

➤ More information starting on page 76

# 4

## Surge protection for transmitter and receiver systems

Antennas are often in exposed locations. Therefore, use high-performance surge protection with low attenuation for your system.

➤ More information starting on page 86

## Contents

Surge protection for power supplies	8
Protection for power supply systems	10
Precisely tailored protection for every requirement	22
UL-compliant surge protection	34
Reliable protection for modern systems	42
Surge protection for measurement and control technology	48
Narrow protection for MCR applications	52
Intelligent and predictive	62
Surge protection and terminal blocks	68
Robust surge protection	72
Surge protection for information technology	76
Protection for transmitter and receiver systems	86
EMC filters	90
Power Reliability	98

# Interference-free power supply and signal transmission

## Surge voltages – An underestimated danger

Several million lightning strikes occur throughout the world every single day. Ten percent of these are ground bolts with surge currents up to 200,000 amps. In addition to the discharges caused by thunderstorms, surge voltages also occur within local power grids. These are caused, for example, by switching operations and electrostatic discharges. Whatever their cause, time and again surge voltages lead to device defects and system failures.



## Fundamental protective measures and devices

Coordinated protective measures and protective devices are essential to ensure the comprehensive protection of buildings and systems against the effects of lightning strikes and overvoltages. This protection can be classified as follows:

### External lightning protection:

The purpose of the external lightning protection system is to provide the lightning with a defined path to ground and thus effectively minimize the danger of a direct strike for the object.

### Internal lightning protection:

The internal lightning protection system prevents the formation of harmful sparks within the system and thus reliably protects the infrastructure.

### Grounding and equipotential bonding:

The grounding system ensures that the discharged lightning current is safely distributed in the ground and that effective equipotential bonding can be established.

### Coordinated SPD system

A coordinated SPD system is a multi-level, coordinated system of surge protective devices.

- Type 1 protection level: Powerful lightning current arrester (type 1+2 combined lightning current and surge arrester or type 1+2 special combined lightning current and surge arrester)
- Type 2 protection level: Protection against surge voltages caused by indirect lightning strikes and switching operations (type 2 surge protective device)
- Type 3 protection level: Surge protection for sensitive end devices (type 3 device protection)

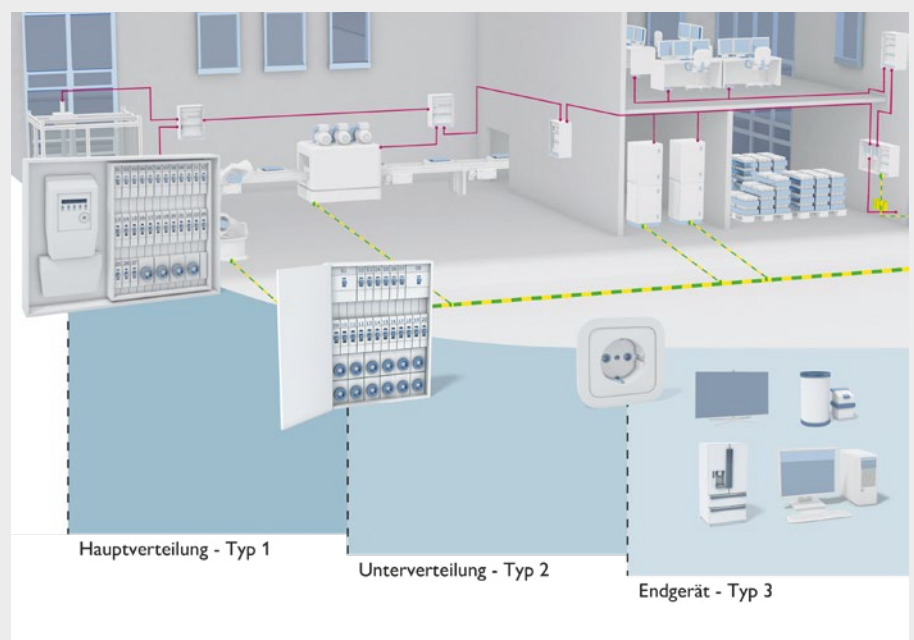

Three-level protection concept in a building

# Interference-free power supply and signal transmission

## All-round safety with the protective circuit

The protective circuit principle defines complete protection against surge voltages.

An imaginary circle is drawn around the devices, plants, or systems to be protected. At all points where cables, conductors, or lines intersect this circle,

surge protective devices that correspond to the rated data of the respective power supply or signal type must be installed. In order to consistently protect objects against conducted surge voltage couplings, the following areas should be considered:

### Protection for data and signals

Protective devices for the requirements of measurement and control technology as well as for data and communication interfaces with application-specific connections ensure the availability of your application.



### Protection for the power supply

From feed-in to the end device, our SPDs provide reliable protection in AC, linear DC, and PV systems. You can use these to provide your systems with permanent protection against damaging voltage peaks.

# Surge protection for power supplies

1

## From feed-in to the end device

The power supply is the part of a system in which particularly high surge voltages occur. All system parts, from the incoming supply to the load, can be directly affected. A powerful surge protection system ensures an uninterrupted power supply, and thus also a higher level of system availability.

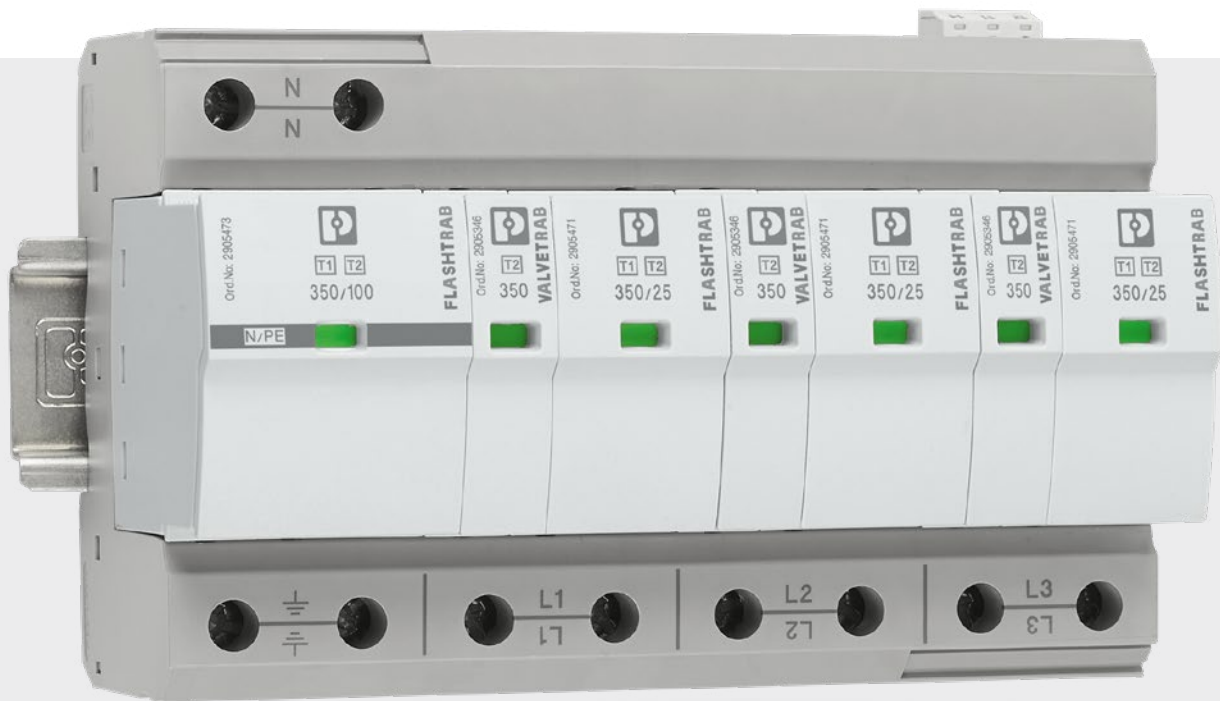

### Universal protection

Products of the SEC family are the first choice for integrating surge protection into industrial systems and control cabinets.

➤ More information starting on page 10

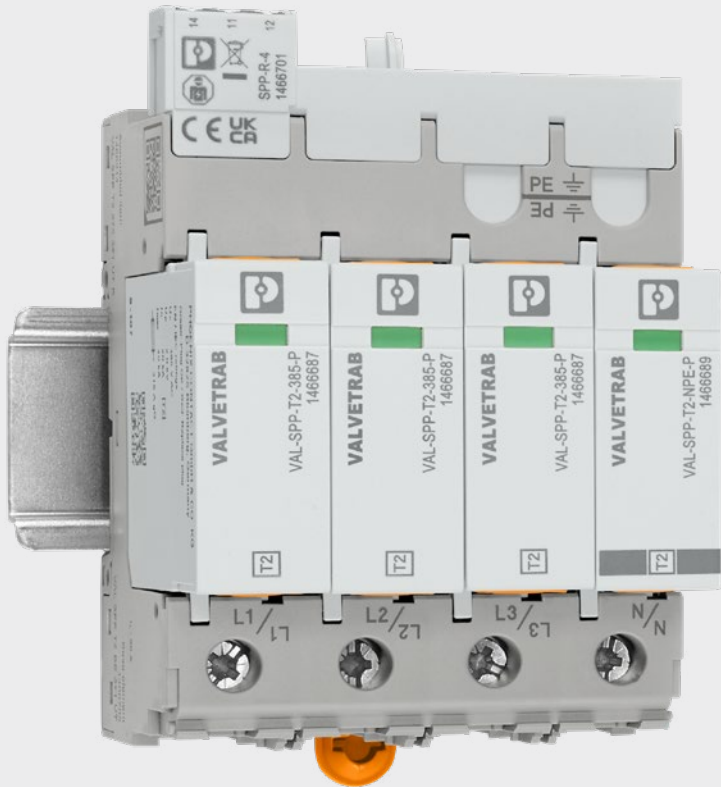

### Application-related protection

Each application has its own special conditions and requirements. Therefore, the surge protection should be tailored to these as best as possible. The right products for protecting individual requirements.

➤ More information starting on page 22



### Protection directly at the end device

Sensitive end devices need special protection. Generally, this is installed directly upstream of the end devices to be protected. Various designs enable installation in a wide range of applications.

➤ More information starting on page 42



## Type 1+2, type 2, and type 3 surge protective devices



### Type 1+2 combined lightning current and surge arrester

Typical installation location: feed-in.  
Meets the requirements of test classes T1 (lightning currents) and T2 (surge voltages).



### Type 2 surge protective device

Typical installation location: subdistribution systems, machine control cabinets. Surge protective device in accordance with test class T2.



### Type 3 device protection

Typical installation location: Directly at the end device. Surge protective device in accordance with test class T3.

### Type 1+2 special combined lightning current and surge arrester

The type 1+2 special combined lightning current and surge arrester differs fundamentally from the type 1+2 version. This is because the type 1+2 special combined lightning current and surge arrester contains two independent protective devices that are connected in parallel in a very small space. A combination of a type 1 spark gap without line follow current and a type 2 varistor arrester in one protective device.

The voltage-switching spark gap (SPD type 1+2) works ideally in combination with a voltage-limiting varistor (SPD type 2). In this combination, two autonomous protective devices in one compact block ensure optimum response behavior, optimal system protection, and a long service life for the components.

The type 1+2 special combined lightning current and surge arrester is perfectly suited for maximum protection of installations and devices.



Type 1+2 special combined lightning current and surge arrester – FLT-SEC-T1+T2-3S-350

### Type 1+2 combined lightning current and surge arresters with integrated backup fuse

The FLT-SEC-HYBRID is a combination of a spark gap without line follow current and a surge-proof fuse, and can therefore be used without a separate backup fuse. This means that long cable routes from and to the backup fuse are no longer needed. This has further positive effects on the voltage protection level.

With a short-circuit current rating up to 100 kA, use in large power distribution systems is also possible.



Type 1+2 combined lightning current and surge arrester – FLT-SEC-H-T1-1C-264/25

# Universal protection for power supply systems

## For universal use

With the surge protective devices of the SEC family, you can protect practically any power supply in standard applications against surge voltages.

From system manufacturing and machine building, to building installation, right through to infrastructure applications, the broad portfolio of the SEC family features products for comprehensive protection concepts.

All of the type 1+2, type 2, and type 3 surge protective devices feature extraordinary durability and high performance in the field of lightning current and surge protection.

Installation is cost-effective and space-saving due to the uniform compact design of the surge protective devices and the fact that they do not need a backup fuse.

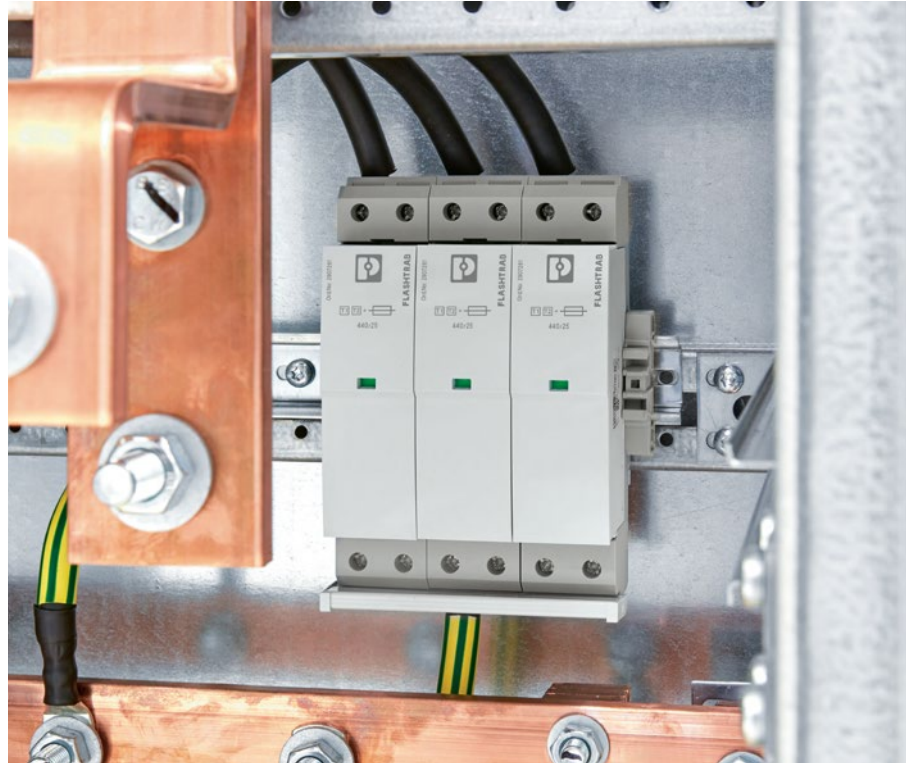

## Tailored to requirements

The combined lightning current and surge arrester FLT-SEC-ZP2... (-SV) is designed for 40 mm busbars and can be installed in any meter cabinet to save space. It satisfies the requirements of the VDE-AR-N 4100 standard. The power can be fed in via SH switches, feed-in adapters, or busbar terminals. Versions with integrated voltage pick-off enable the supply of additional components in the meter cabinet, such as smart meter gateways. Despite the integrated voltage pick-off, the design remains slim and fits into the mains connection compartment even with two SH switches.

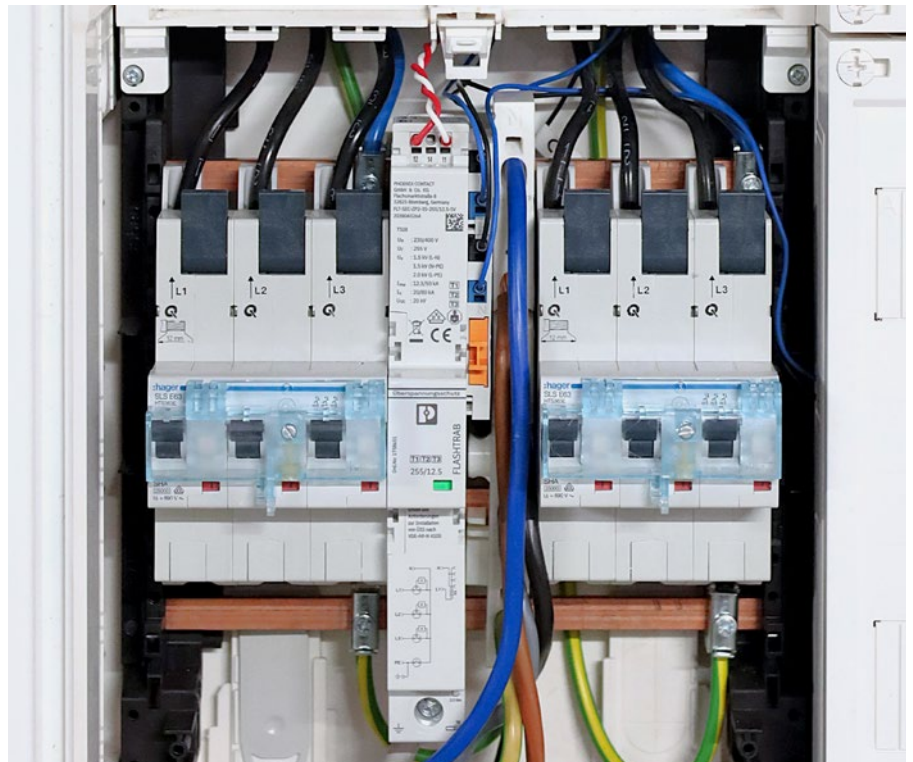

# Advantages for your control cabinet building

- 1
- 2
- 3
- 4
- 5

Surge protection for power supplies



## Efficient

Plan your control cabinets more efficiently and easily, thanks to compact surge protective devices for backup-fuse-free applications. Due to their uniform design and uniform haptics, installing the SEC family products is very easy.

## Pluggable

Consistent pluggability ensures a high degree of convenience, for example when taking insulation measurements in the system. Instead of reaching into the system, simply pull the plug. In the unlikely event of a defective protective plug, it is very easy to replace.

## Informed





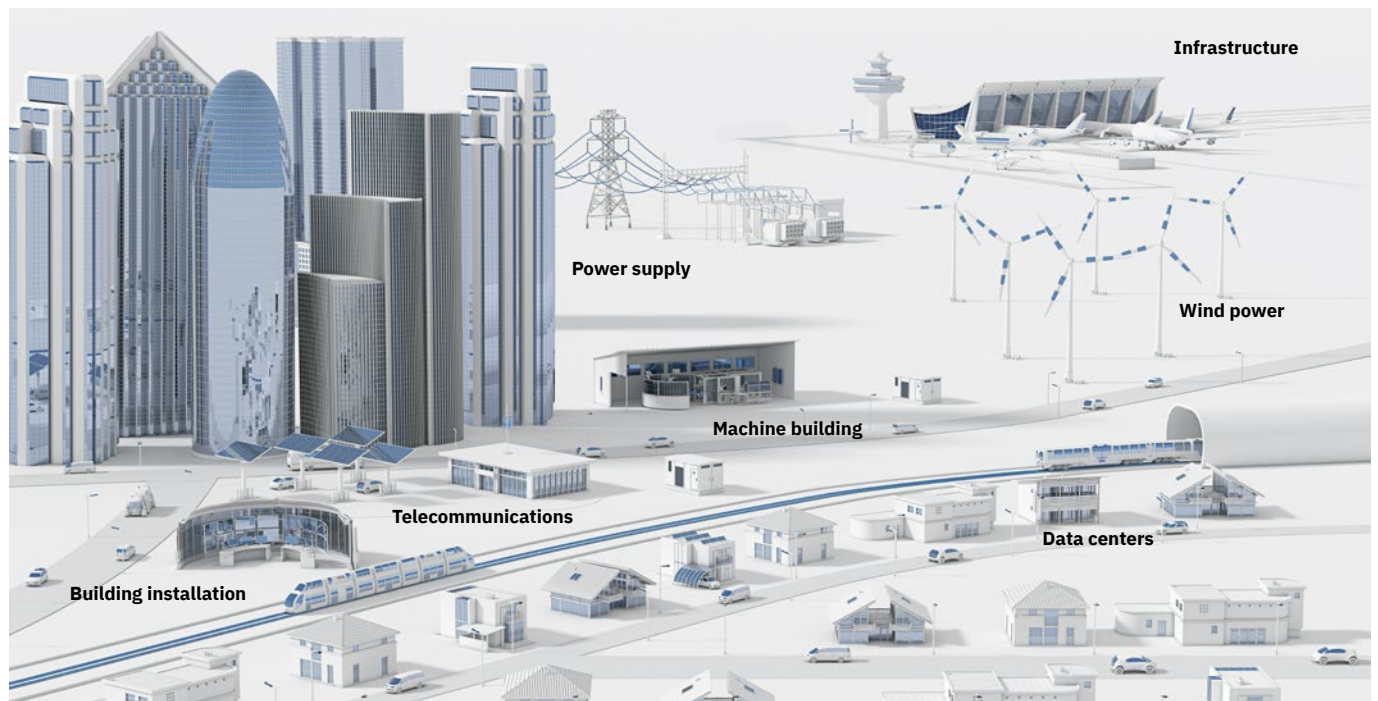



Stay informed about the status of the surge protective devices. The floating remote indication contact can be integrated easily into alarm concepts. The mechanical-optical status indicator provides information on site without additional energy consumption.

## For installation in any control cabinet



*With coordinated voltage versions, the surge protective devices of the SEC family can be used in all conventional power supply systems for standard installation applications*

# Universal protection for power supply systems

Type 1+2 combined lightning current and surge arresters with integrated backup fuse				
				
<b>Number of positions</b>	<b>1-pos.</b>	<b>3-pos.</b>	<b>1-pos.</b>	<b>3-pos.</b>
Nominal voltage	240 V AC (TN-C)	240/415 V AC (TN-C)	400 V AC (TN) 400 V AC (IT)	400/690 V AC (TN-C) 400 V AC (IT)
Type in accordance with IEC	T1 / T2	T1 / T2	T1 / T2	T1 / T2
Maximum continuous operating voltage $U_c$	264 V AC	264 V AC	440 V AC	440 V AC
Voltage protection level	$\leq 1.5$ kV	$\leq 1.5$ kV	$\leq 2.5$ kV	$\leq 2.5$ kV
Approvals				
Nominal discharge current	25 kA	25 kA	25 kA	25 kA
Lightning impulse current	25 kA	25 kA	25 kA	25 kA
Type	FLT-SEC-H-T1-1C-264/25-FM	FLT-SEC-H-T1-3C-264/25-FM	FLT-SEC-H-T1-1C-440/25-FM	FLT-SEC-H-T1-3C-440/25-FM
Item no.	<a href="#">2801615</a>	<a href="#">2905871</a>	<a href="#">2907259</a>	<a href="#">2907260</a>

Type 1+2 combined lightning current and surge arrester with high short-circuit current rating, also for unstable grids			
			
<b>Number of positions</b>	<b>2-pos.</b>	<b>3-pos.</b>	<b>4-pos.</b>
Nominal voltage	240 V AC (TN-S) 240 V AC (TT)	240/415 V AC (TN-C)	240/415 V AC (TN-S) 240/415 V AC (TT)
Type in accordance with IEC	T1 / T2	T1 / T2	T1 / T2
Maximum continuous operating voltage $U_c$	350 V AC	350 V AC	350 V AC
Voltage protection level	$\leq 1.5$ kV (L-N) $\leq 1.5$ kV (N-PE)	$\leq 1.5$ kV	$\leq 1.5$ kV (L-N) $\leq 1.5$ kV (N-PE)
Max. backup fuse F2	315 A (gG)	315 A (gG)	315 A (gG)
Approvals			
Nominal discharge current	25 kA (L-N) 100 kA (N-PE)	25 kA	25 kA (L-N) 100 kA (N-PE)
Lightning impulse current	25 kA (L-N) 100 kA (N-PE)	25 kA	25 kA (L-N) 100 kA (N-PE)
Type	FLT-SEC-P-T1-1S-350/25-FM	FLT-SEC-P-T1-3C-350/25-FM	FLT-SEC-P-T1-3S-350/25-FM
Item no.	<a href="#">2905415</a>	<a href="#">2905419</a>	<a href="#">2905421</a>







# Universal protection for power supply systems

## Type 1+2 combined lightning current and surge arresters for 400/690 V and 400 V IT and a high short-circuit current rating

			
<b>Number of positions</b>	<b>1-pos.</b>	<b>3-pos.</b>	<b>4-pos.</b>
Nominal voltage	400 V AC (TN-C) 400 V AC (IT)	400/690 V AC (TN-C) 400 V AC (IT)	400/690 V AC (TN-S) 400/690 V AC (TT)
Type in accordance with IEC	T1 / T2	T1 / T2	T1 / T2
Maximum continuous operating voltage $U_c$	440 V AC	440 V AC	440 V AC
Voltage protection level	$\leq 2.5$ kV	$\leq 2.5$ kV	$\leq 2.5$ kV (L-N) $\leq 2.5$ kV (N-PE)
Max. backup fuse F2	400 A (gG)	400 A (gG)	400 A (gG)
Approvals			
Nominal discharge current	35 kA	35 kA	35 kA (L-N) 100 kA (N-PE)
Lightning impulse current	35 kA	35 kA	35 kA (L-N) 100 kA (N-PE)
Type	FLT-SEC-P-T1-1C-440/35-FM	FLT-SEC-P-T1-3C-440/35-FM	FLT-SEC-P-T1-3S-440/35-FM
Item no.	2905987	2905988	2908264

# Universal protection for power supply systems

## Type 1+2 combined lightning current and surge arresters for very high lightning currents and a high short-circuit current rating

			
<b>Number of positions</b>	<b>2-pos.</b>	<b>3-pos.</b>	<b>4-pos.</b>
Nominal voltage	240 V AC (TN-S) 240 V AC (TT)	240/415 V AC (TN-C)	240/415 V AC (TN-S) 240/415 V AC (TT)
Type in accordance with IEC	T1 / T2	T1 / T2	T1 / T2
Maximum continuous operating voltage $U_c$	264 V AC (L-N) 350 V AC (N-PE)	264 V AC	264 V AC (L-N) 350 V AC (N-PE)
Voltage protection level	$\leq 2.5$ kV (L-N) $\leq 1.5$ kV (N-PE)	$\leq 2.5$ kV	$\leq 2.5$ kV (L-N) $\leq 1.5$ kV (N-PE)
Max. backup fuse F2	500 A (gG)	500 A (gG)	500 A (gG)
Approvals			
Nominal discharge current	50 kA (L-N) 100 kA (N-PE)	50 kA	50 kA (L-N) 100 kA (N-PE)
Lightning impulse current	50 kA (L-N) 100 kA (N-PE)	50 kA	50 kA (L-N) 100 kA (N-PE)
Type	FLT-SEC-P-T1-1S-264/50-FM	FLT-SEC-P-T1-3C-264/50-FM	FLT-SEC-P-T1-3S-264/50-FM
Item no.	<a href="#">2907388</a>	<a href="#">2907390</a>	<a href="#">2909589</a>





## Type 1+2 special combined lightning current and surge arresters, lightning current arrester and surge protection



















			
<b>Number of positions</b>	<b>2-pos.</b>	<b>3-pos.</b>	<b>4-pos.</b>
Nominal voltage	240 V AC (TN-S) 240 V AC (TT)	240/415 V AC (TN-C)	240/415 V AC (TN-S) 240/415 V AC (TT)
Type in accordance with IEC	T1 + T2	T1 + T2	T1 + T2
Maximum continuous operating voltage $U_c$	350 V AC	350 V AC	350 V AC
Voltage protection level	$\leq 2.2$ kV (L-PE) $\leq 1.5$ kV (L-N) $\leq 1.5$ kV (N-PE)	$\leq 1.5$ kV	$\leq 2.2$ kV (L-PE) $\leq 1.5$ kV (L-N) $\leq 1.5$ kV (N-PE)
Max. backup fuse F2	315 A (gG)	315 A (gG)	315 A (gG)
Approvals			
Nominal discharge current	25 kA (L-N) 25 kA (L-PE) 100 kA (N-PE)	25 kA	25 kA (L-N) 25 kA (L-PE) 100 kA (N-PE)
Lightning impulse current	25 kA (L-N) 25 kA (L-PE) 100 kA (N-PE)	25 kA	25 kA (L-N) 25 kA (L-PE) 100 kA (N-PE)
Type	FLT-SEC-T1+T2-1S-350/25-FM	FLT-SEC-T1+T2-3C-350/25-FM	FLT-SEC-T1+T2-3S-350/25-FM
Item no.	<a href="#">2905466</a>	<a href="#">2905469</a>	<a href="#">2905470</a>

# Universal protection for power supply systems

1  
2  
3  
4  
5



Surge protection for power supplies

Type 1+2+3 combined lightning current and surge arrester for 40 mm busbar systems with voltage pick-off				
				
<b>Number of positions</b>	<b>3-pos.</b> <span style="background-color: #e91e63; color: white; padding: 2px;">NEW</span>	<b>3-pos.</b> <span style="background-color: #e91e63; color: white; padding: 2px;">NEW</span>	<b>4-pos.</b> <span style="background-color: #e91e63; color: white; padding: 2px;">NEW</span>	<b>4-pos.</b> <span style="background-color: #e91e63; color: white; padding: 2px;">NEW</span>
Nominal voltage	230/400 V AC (TN-C)	230/400 V AC (TN-C)	230/400 V AC (TN-S) 230/400 V AC (TT)	230/400 V AC (TN-S) 230/400 V AC (TT)
Type in accordance with IEC	T1 + T2 + T3	T1 + T2 + T3	T1 + T2 + T3	T1 + T2 + T3
Maximum continuous operating voltage $U_c$	255 V AC	255 V AC	255 V AC	255 V AC
Voltage protection level	$\leq 1.5$ kV	$\leq 1.5$ kV	$\leq 1.5$ kV (L-N) $\leq 1.5$ kV (N-PE)	$\leq 1.5$ kV (L-N) $\leq 1.5$ kV (N-PE)
Max. backup fuse F2	315 A (gG)	315 A (gG)	315 A (gG)	315 A (gG)
Nominal discharge current	20 kA	20 kA	20 kA (L-N) 80 kA (N-PE)	20 kA (L-N) 80 kA (N-PE)
Lightning impulse current	7.5 kA	12.5 kA	7.5 kA (L-N) 30 kA (N-PE)	12.5 kA (L-N) 50 kA (N-PE)
Combined surge	20 kV	20 kV	20 kV	20 kV
Type	FLT-SEC-ZP2-3C-255/7.5-SV	FLT-SEC-ZP2-3C-255/12.5-SV	FLT-SEC-ZP2-3S-255/7.5-SV	FLT-SEC-ZP2-3S-255/12.5-SV
Item no.	<a href="#">1758650</a>	<a href="#">1758657</a>	<a href="#">1758648</a>	<a href="#">1758651</a>

Type 1+2+3 combined lightning current and surge arresters for 40 mm busbar systems					
					
<b>Number of positions</b>	<b>3-pos.</b>	<b>3-pos.</b>	<b>4-pos.</b>	<b>4-pos.</b>	—
Nominal voltage	230/400 V AC (TN-C)	230/400 V AC (TN-C)	230/400 V AC (TN-S) 230/400 V AC (TT)	230/400 V AC (TN-S) 230/400 V AC (TT)	—
Type in accordance with IEC	T1 + T2 + T3	T1 + T2 + T3	T1 + T2 + T3	T1 + T2 + T3	—
Maximum continuous operating voltage $U_c$	255 V AC	255 V AC	255 V AC	255 V AC	—
Voltage protection level	$\leq 1.5$ kV	$\leq 1.5$ kV	$\leq 1.5$ kV (L-N) $\leq 1.5$ kV (N-PE)	$\leq 1.5$ kV (L-N) $\leq 1.5$ kV (N-PE)	—
Max. backup fuse F2	160 A (gG)	160 A (gG)	160 A (gG)	160 A (gG)	—
Approvals	  	  	  	  	—
Nominal discharge current	20 kA	20 kA	20 kA (L-N) 80 kA (N-PE)	20 kA (L-N) 80 kA (N-PE)	—
Lightning impulse current	7.5 kA	12.5 kA	7.5 kA (L-N) 30 kA (N-PE)	12.5 kA (L-N) 50 kA (N-PE)	—
Combined surge	20 kV	20 kV	20 kV	20 kV	—
Type	FLT-SEC-ZP2-3C-255/7.5	FLT-SEC-ZP2-3C-255/12.5	FLT-SEC-ZP2-3S-255/7.5	FLT-SEC-ZP2-3S-255/12.5	FLT-SEC-ZP2 FM-MODULE
Item no.	<a href="#">1168942</a>	<a href="#">1168946</a>	<a href="#">1168940</a>	<a href="#">1168943</a>	<a href="#">1168947</a>

# Universal protection for power supply systems





Type 2 surge protection for 240/415 V systems			
			
<b>Number of positions</b>	<b>2-pos.</b>	<b>3-pos.</b>	<b>4-pos.</b>
Nominal voltage	240 V AC (TN-S) 240 V AC (TT)	240/415 V AC (TN-C)	240/415 V AC (TN-S) 240/415 V AC (TT)
Type in accordance with IEC	T2	T2	T2
Maximum continuous operating voltage $U_c$	350 V AC (L-N) 264 V AC (N-PE)	350 V AC	350 V AC (L-N) 264 V AC (N-PE)
Voltage protection level	$\leq 1.5$ kV (L-N) $\leq 1.5$ kV (N-PE)	$\leq 1.5$ kV	$\leq 1.5$ kV (L-N) $\leq 1.5$ kV (N-PE)
Max. backup fuse F2	315 A (gG)	315 A (gG)	315 A (gG)
Approvals			
Nominal discharge current	20 kA	20 kA	20 kA
Type	VAL-SEC-T2-1S-350-FM	VAL-SEC-T2-3C-350-FM	VAL-SEC-T2-3S-350-FM
Item no.	<a href="#">2905333</a>	<a href="#">2905339</a>	<a href="#">2905340</a>

Type 2 surge protection for 240/415 V systems, free of leakage current, even for unstable grids			
			
<b>Number of positions</b>	<b>2-pos.</b>	<b>3-pos.</b>	<b>4-pos.</b>
Nominal voltage	240 V AC (TN-S) 240 V AC (TT)	240/415 V AC (TN-C)	240/415 V AC (TN-S) 240/415 V AC (TT)
Type in accordance with IEC	T2	T2	T2
Maximum continuous operating voltage $U_c$	350 V AC (L-N) 264 V AC (N-PE)	350 V AC	350 V AC (L-N) 264 V AC (N-PE)
Voltage protection level	$\leq 1.5$ kV (L-N) $\leq 1.5$ kV (N-PE)	$\leq 1.5$ kV	$\leq 1.5$ kV (L-N) $\leq 1.5$ kV (N-PE)
Max. backup fuse F2	200 A (gG)	200 A (gG)	200 A (gG)
Approvals			
Nominal discharge current	10 kA (L-N) 20 kA (N-PE)	10 kA	10 kA (L-N) 20 kA (N-PE)
Type	VAL-SEC-T2-1S-350VF-FM	VAL-SEC-T2-3C-350VF-FM	VAL-SEC-T2-3S-350VF-FM
Item no.	<a href="#">2909592</a>	<a href="#">2909591</a>	<a href="#">2909590</a>

# Universal protection for power supply systems

1  
2  
3  
4  
5

Surge protection for power supplies

Type 2 surge protection for 400/690 V and 400 V IT systems		
		
<b>Number of positions</b>	<b>3-pos.</b>	<b>3-pos.</b>
Nominal voltage	400/690 V AC (TN-C) 400 V AC (IT)	400/690 V AC (TN-S) 400 V AC (IT)
Type in accordance with IEC	T2	T2
Maximum continuous operating voltage $U_c$	440 V AC	440 V AC
Voltage protection level	$\leq 1.9$ kV	$\leq 4$ kV (L-N) $\leq 1.9$ kV (N-PE)
Max. backup fuse F2	315 A (gG)	315 A (gG)
Approvals		-
Nominal discharge current	20 kA	20 kA
Type	VAL-SEC-T2-3C-440-FM	VAL-SEC-T2-4+0-440-FM
Item no.	<a href="#">2909968</a>	<a href="#">1076468</a>





Type 2 surge protection for 120/208 V systems			
			
<b>Number of positions</b>	<b>2-pos.</b>	<b>3-pos.</b>	<b>4-pos.</b>
Nominal voltage	120 V AC (TN-S) 120 V AC (TT)	120/208 V AC (TN-C)	120/208 V AC (TN-S) 120/208 V AC (TT)
Type in accordance with IEC	T2	T2	T2
Maximum continuous operating voltage $U_c$	175 V AC (L-N) 150 V AC (N-PE)	175 V AC	175 V AC (L-N) 150 V AC (N-PE)
Voltage protection level	$\leq 0.85$ kV (L-N) $\leq 0.95$ kV (N-PE)	$\leq 0.85$ kV	$\leq 0.85$ kV (L-N) $\leq 0.95$ kV (N-PE)
Max. backup fuse F2	315 A (gG)	315 A (gG)	315 A (gG)
Approvals			
Nominal discharge current	20 kA	20 kA	20 kA
Type	VAL-SEC-T2-1S-175-FM	VAL-SEC-T2-3C-175-FM	VAL-SEC-T2-3S-175-FM
Item no.	<a href="#">2905348</a>	<a href="#">2905353</a>	<a href="#">2905354</a>

# Universal protection for power supply systems

## Type 2 surge protection for unipolar DC applications

				
<b>Number of positions</b>	<b>2-pos.</b>	<b>2-pos.</b>	<b>2-pos.</b>	<b>2-pos.</b>
Nominal voltage	48 V DC ... 60 V DC	100 V DC ... 120 V DC	200 V DC ... 220 V DC	350 V DC ... 400 V DC
Type in accordance with IEC	T2	T2	T2	T2
Maximum continuous operating voltage $U_c$	75 V DC	150 V DC	250 V DC	450 V DC
Voltage protection level	$\leq 0.9$ kV (DC-DC) $\leq 0.5$ kV (DC-PE)	$\leq 1.8$ kV (DC-DC) $\leq 0.85$ kV (DC-PE)	$\leq 3$ kV (DC-DC) $\leq 1.5$ kV (DC-PE)	$\leq 3$ kV (DC-DC) $\leq 1.5$ kV (DC-PE)
Max. backup fuse F2	20 A DC (gG / B at $I_{SCCR} > 200$ A)	20 A (gG / B at $I_{SCCR} > 200$ A)	20 A (gG / B at $I_{SCCR} > 200$ A)	20 A (gG / B at $I_{SCCR} > 200$ A)
Approvals				
Nominal discharge current	20 kA	20 kA	20 kA	20 kA
Type	VAL-SEC-T2-2+0-48DC-FM	VAL-SEC-T2-2+0-120DC-FM	VAL-SEC-T2-2+0-220DC-FM	VAL-SEC-T2-2+0-380DC-FM
Item no.	<a href="#">2907865</a>	<a href="#">2907874</a>	<a href="#">2907875</a>	<a href="#">2907876</a>

## Type 2 surge protection for unipolar isolated DC applications

				
<b>Number of positions</b>	<b>2-pos.</b>	<b>2-pos.</b>	<b>2-pos.</b>	<b>2-pos.</b>
Nominal voltage	40 V DC ... 60 V DC	100 V DC ... 120 V DC	200 V DC ... 220 V DC	350 V DC ... 400 V DC
Type in accordance with IEC	T2	T2	T2	T2
Maximum continuous operating voltage $U_c$	75 V DC	150 V DC	250 V DC	450 V DC
Voltage protection level	$\leq 0.9$ kV (DC-DC) $\leq 1$ kV (DC-PE)	$\leq 1.8$ kV (DC-DC) $\leq 1.3$ kV (DC-PE)	$\leq 3$ kV (DC-DC) $\leq 1.9$ kV (DC-PE)	$\leq 3$ kV (DC-DC) $\leq 1.9$ kV (DC-PE)
Max. backup fuse F2	20 A DC (gG / B at $I_{SCCR} > 200$ A)	20 A (gG / B at $I_{SCCR} > 200$ A)	20 A (gG / B at $I_{SCCR} > 200$ A)	10 A (gG/B at $I_{SCCR} > 100$ A)
Nominal discharge current	20 kA	20 kA	20 kA	20 kA
Type	VAL-SEC-T2-2+F-48DC-FM	VAL-SEC-T2-2+F-120DC-FM	VAL-SEC-T2-2+F-220DC-FM	VAL-SEC-T2-2+F-380DC-FM
Item no.	<a href="#">1033786</a>	<a href="#">1033788</a>	<a href="#">1033789</a>	<a href="#">1033790</a>

# Universal protection for power supply systems











1  
2  
3  
4  
5

Surge protection for power supplies

## Type 3 device protection with Push-in connection

				
<b>Number of positions</b>	<b>2-pos.</b>	<b>2-pos.</b>	<b>2-pos.</b>	<b>2-pos.</b>
Nominal voltage	24 V AC (TN-S)	60 V AC (TN-S)	120 V AC (TN-S) 120 V AC (TT)	240 V AC (TN-S) 240 V AC (TT)
Type in accordance with IEC	T3	T3	T2 / T3	T2 / T3
Maximum continuous operating voltage $U_c$	34 V AC	80 V AC	150 V AC	264 V AC
Voltage protection level	$\leq 0.2$ kV (L-N) $\leq 0.6$ kV (N-PE)	$\leq 0.48$ kV (L-N) $\leq 0.8$ kV (N-PE)	$\leq 0.75$ kV (L-N) $\leq 0.85$ kV (N-PE)	$\leq 1.25$ kV (L-N) $\leq 1.4$ kV (N-PE)
Max. backup fuse F2	32 A (gG / B / C)	32 A (gG / B / C)	32 A (gG / B / C)	32 A (gG / B / C)
Approvals		DNV 	DNV 	DNV 
Nominal discharge current	1 kA	2 kA	5 kA	5 kA
Combined surge	2 kV	4 kV	6 kV	6 kV
Type	PLT-SEC-T3-24-FM-PT	PLT-SEC-T3-60-FM-PT	PLT-SEC-T3-120-FM-PT	PLT-SEC-T3-230-FM-PT
Item no.	2907925	2907926	2907927	2907928

## Type 3 device protection with screw connection

					
<b>Number of positions</b>	<b>2-pos.</b>	<b>2-pos.</b>	<b>2-pos.</b>	<b>2-pos.</b>	<b>4-pos.</b>
Nominal voltage	24 V AC (TN-S)	60 V AC (TN-S)	120 V AC (TN-S) 120 V AC (TT)	240 V AC (TN-S) 240 V AC (TT)	230/400 V AC (TN-S) 230/400 V AC (TT)
Type in accordance with IEC	T3	T3	T2 / T3	T2 / T3	T3
Maximum continuous operating voltage $U_c$	34 V AC	80 V AC	150 V AC	264 V AC	264 V AC
Voltage protection level	$\leq 0.2$ kV (L-N) $\leq 0.6$ kV (N-PE)	$\leq 0.48$ kV (L-N) $\leq 0.8$ kV (N-PE)	$\leq 0.75$ kV (L-N) $\leq 0.85$ kV (N-PE)	$\leq 1.25$ kV (L-N) $\leq 1.4$ kV (N-PE)	$\leq 1.4$ kV (L-N) $\leq 1.5$ kV (N-PE)
Max. backup fuse F2	32 A (gG / B / C)	32 A (gG / B / C)	32 A (gG / B / C)	32 A (gG / B / C)	— (not necessary)
Approvals	DNV 	DNV 	DNV 	DNV 	ETL
Nominal discharge current	1 kA	2 kA	5 kA	5 kA	3 kA
Combined surge	2 kV	4 kV	6 kV	6 kV	6 kV
Type	PLT-SEC-T3-24-FM-UT	PLT-SEC-T3-60-FM-UT	PLT-SEC-T3-120-FM-UT	PLT-SEC-T3-230-FM-UT	PLT-SEC-T3-3S-230-FM
Item no.	2907916	2907917	2907918	2907919	2905230

Surge protection for power supplies

## Precisely tailored protection for every requirement

Individual for each industry

Protect your systems with industry-oriented surge protection. From photovoltaics to wind power, building installation, and e-mobility, our products offer optimally coordinated solutions for every requirement. Robust, durable, and certified, for maximum availability and reliable protection.



### Your advantages

- ✓ Optimally tailored protection thanks to sector-specific products
- ✓ Robust and durable with test methods designed for the installation location
- ✓ Market-specific products for compliance with regional standards and stipulations

# Application-related protection for different applications



## The specialists

From renewable energies through to machine building. VALVETRAB SPP are the specialists for different applications.



## The robust ones

POWERTRAB is an extremely robust lightning current arrester for applications in harsh conditions and exposed locations.



## The minimalists

BLOCKTRAB T2 products are ideally suited for protecting LED street lighting. Optimum protection in the tightest spaces.

## Surge protection for all energy sectors

With the right surge protection, you ensure the availability of your application. Whether for renewable and thus clean energy generation or for the mobility of the future, the right protection against surge voltages is simply essential.

Networked buildings, industrial systems, and the associated infrastructure are the basis for automated value creation. These should be equipped with surge protection specially developed for this purpose.



Photovoltaics	Wind power	E-mobility	Building installation	Machine building	Infrastructure
More information starting on page 32	More information starting on page 27	More information starting on page 26	More information starting on page 28	More information starting on page 28	More information starting on page 33

# The right surge protection for your application

## Machine building and systems manufacturing

Control cabinets are the control centers of electrotechnical systems and production facilities. They therefore have to be protected accordingly with care.

The sensitive electronic components in the control cabinet have to be protected reliably against surge voltages. They are particularly susceptible to damage caused by lightning currents and surge voltage coupling across the power grid.

In order to avoid costly failures and downtimes, surge protection should be taken into consideration as early as when planning the system components and their supply.

In our broad portfolio of surge protective devices for various applications in machine building and systems manufacturing, you will find the right protection for your application.

Protective devices with specially tailored voltage ranges, integrated, coordinated backup fuses, or, upon request, even versions designed to meet the requirements of global markets increase the availability of your systems and thus protect against costly production downtimes.



*Increased system availability*

## Photovoltaic systems

Solar power is an essential source of renewable energy. Decreasing system costs mean that photovoltaic power generation systems are attractive not only from an ecological perspective. They are also extremely competitive from an economic point of view when compared with conventional power generation. In order to provide optimum protection against surge voltages for the various system parts such as PV panels, inverters, and battery storage systems, surge protection must be used.

The parameters on the DC side of photovoltaic systems differ substantially from those on the AC side. High system DC voltages are generated and a photovoltaic generator is operated close to its short-circuit current. Fuse mechanisms that are typically used for AC applications, such as backup fuses, are not used here. Due to these special features of the DC side, surge protective devices that have been specifically developed for photovoltaic systems must be used.

Phoenix Contact provides a broad product range of surge protective devices specially designed for the DC side of photovoltaic systems.

Type 1+2 combined lightning current and surge arresters as well as type 2 for generator voltages of up 1,500 V DC are included in this portfolio. Here, you can choose between plug-in and non-plug-in versions.

Naturally, our portfolio does not just include suitable DC and AC surge protection for your photovoltaics application, but also string combiner boxes (SCBs) for rooftop systems and ground-mounted systems.

➤ More information on this topic at: [phoenixcontact.com/pv-surge](https://phoenixcontact.com/pv-surge)



*Uninterruptible energy generation*

## Wind power

Whether on rough seas, flat coastal landscapes, high plateaus, or wide plains, wind turbine generators (WTGs) are exposed to extreme weather conditions wherever installed. These systems, which are up to 200 m high, are particularly at risk during thunderstorms. It is therefore very important to protect the electrical and electronic system parts and components against lightning currents and surge voltages. If a WTG fails, this results in both high yield losses and costly maintenance work.

With its robust housing, the POWERTRAB type 1+2 combined lightning current and surge arrester is specially designed for harsh conditions. Featuring a rated voltage of 800 V AC and a discharge capacity of 35 kA per channel, it is ideal for use in 690 V IT grids in wind turbine generators. The specially designed VAL-SPP-T2-750... and VAL-SPP-T2-800WE... versions are available for targeted protection of the rotor and stator in wind turbine generators.



*Safe system operation in exposed locations*

## E-mobility

Charging stations and EV chargers must be available at all times – day and night, and in any weather. In order to protect the charging infrastructure of your connected e-vehicle against surge voltages caused by lightning strikes or switching operations, it is included in a comprehensive overvoltage protection concept.

This allows you to ensure that the charging process continues uninterrupted and unaffected by surge voltages, and that your electric car is ready for use at any time.

You can use the type 1+2+3 FLT-MB lightning current arrester to safely and reliably protect the sensitive electronic components in EV charging stations. The protective device works wear-free due to the triggered carbon spark gap technology and makes a decisive contribution to the high availability of your charging infrastructure and your electric car.



*Protection for the charging infrastructure*

## Infrastructure

LED technology provides durable solutions for road and building lighting. Premature blackouts caused by surge voltages significantly reduce the savings potential of energy-saving LED lights. This is often caused by ballasts which are sensitive to transient voltages. The BLOCKTRAB surge protective devices have been designed such that they can be installed directly in the light. Due to the increased insulation, they can be used in LED applications in protection class II equipment without any further measures.



Depending on requirements, the devices can be installed in through-wiring or branch wiring and are designed either as versions for lights with a grounded connection (L, L', N, PE) or for lights with an insulated connection (L, L', N).







*Consistent availability*

# Application-related protection

## Type 1+2+3 combined lightning current and surge arrester





				
<b>Number of positions</b>	<b>4-pos.</b>	<b>4-pos.</b>	<b>4-pos.</b>	<b>4-pos.</b>
Nominal voltage	240/415 V AC (TN-S) 240/415 V AC (TT)	240/415 V AC (TN-S) 240/415 V AC (TT)	240/415 V AC (TN-C)	240/415 V AC (TN-C)
Type in accordance with IEC	T1 + T2 + T3	T1 + T2 + T3	T1 + T2 + T3	T1 + T2 + T3
Maximum continuous operating voltage $U_c$	264 V AC	264 V AC	264 V AC	264 V AC
Voltage protection level	$\leq 1.5$ kV (L-N) $\leq 1.5$ kV (N-PE)	$\leq 1.5$ kV (L-N) $\leq 1.5$ kV (N-PE)	$\leq 1.5$ kV	$\leq 1.7$ kV
Max. backup fuse F2	315 A (gG)	315 A (gG)	315 A (gG)	315 A (gG)
Approvals				
Nominal discharge current	12.5 kA (L-N) 50 kA (N-PE)	25 kA (L-N) 100 kA (N-PE)	12.5 kA	25 kA
Lightning impulse current	12.5 kA (L-N) 50 kA (N-PE)	25 kA (L-N) 100 kA (N-PE)	12.5 kA	25 kA
Combined surge	6 kV	6 kV	6 kV	6 kV
Type	FLT-MB-T1-264/12.5-3+1-UT	FLT-MB-T1-264/25-3+1-UT-R	FLT-MB-T1-264/12.5-3+0-UT-R	FLT-MB-T1-264/25-3+0-UT-R
Item no.	1380661	1461304	1380660	1461302

## Type 1+2+3 combined lightning current and surge arrester





		
<b>Number of positions</b>	<b>2-pos.</b>	<b>2-pos.</b>
Nominal voltage	240 V AC (TN-S) 240 V AC (TT)	240 V AC (TN-S) 240 V AC (TT)
Type in accordance with IEC	T1 + T2 + T3	T1 + T2 + T3
Maximum continuous operating voltage $U_c$	264 V AC	264 V AC
Voltage protection level	$\leq 1.5$ kV (L-N) $\leq 1.5$ kV (N-PE)	$\leq 1.5$ kV (L-N) $\leq 1.5$ kV (N-PE)
Max. backup fuse F2	315 A (gG)	315 A (gG)
Approvals		
Nominal discharge current	12.5 kA (L-N) 25 kA (N-PE)	25 kA (L-N) 50 kA (N-PE)
Lightning impulse current	12.5 kA (L-N) 25 kA (N-PE)	25 kA (L-N) 50 kA (N-PE)
Combined surge	6 kV	6 kV
Type	FLT-MB-T1-264/12.5-1+1-UT	FLT-MB-T1-264/25-1+1-UT-R
Item no.	1380654	1461300

# Application-related protection

## Type 1+2 combined lightning current and surge arresters for lightning protection level III and IV











		
<b>Number of positions</b>	<b>4-pos.</b>	<b>2-pos.</b>
Nominal voltage	240/415 V AC (TN-S) 240/415 V AC (TT)	240 V AC (TN-S) 240 V AC (TT)
Type in accordance with IEC	T1 / T2	T1 / T2
Maximum continuous operating voltage $U_c$	335 V AC (L-N) 335 V AC (L-PE) 264 V AC (N-PE)	335 V AC (L-N) 335 V AC (L-PE) 264 V AC (N-PE)
Voltage protection level	$\leq 2$ kV (L-PE) $\leq 1.2$ kV (L-N) $\leq 1.7$ kV (N-PE)	$\leq 2$ kV (L-PE) $\leq 1.2$ kV (L-N) $\leq 1.7$ kV (N-PE)
Max. backup fuse F2	160 A (gG)	160 A (gG)
Approvals		
Nominal discharge current	12.5 kA (L-N) 12.5 kA (L-PE) 50 kA (N-PE)	12.5 kA (L-N) 12.5 kA (L-PE) 50 kA (N-PE)
Lightning impulse current	12.5 kA (L-N) 12.5 kA (L-PE) 50 kA (N-PE)	12.5 kA (L-N) 12.5 kA (L-PE) 50 kA (N-PE)
Type	VAL-MS-T1/T2 335/12.5/3+1-FM	VAL-MS-T1/T2 335/12.5/1+1-FM
Item no.	<a href="#">2800183</a>	<a href="#">2800186</a>

## Type 1+2 combined lightning current and surge arresters for high nominal voltages







		
<b>Number of positions</b>	<b>1-pos.</b>	<b>3-pos.</b>
Nominal voltage	690 V AC 554/960 V AC (TN-C) 690 V AC (IT)	690 V AC 554/960 V AC (TN-C) 690 V AC (IT)
Type in accordance with IEC	T1 / T2	T1 / T2
Maximum continuous operating voltage $U_c$	800 V AC (L-PE)	800 V AC (L-PE)
Voltage protection level	$\leq 4.5$ kV	$\leq 4.5$ kV
Max. backup fuse F2	400 A (gG at 2 x 50 mm <sup>2</sup> )	400 A (gG at 2 x 50 mm <sup>2</sup> )
Approvals		
Nominal discharge current	35 kA (L-PE)	35 kA (L-PE)
Lightning impulse current	35 kA	35 kA
Type	PWT 35-800AC-FM	PWT 100-800AC-FM
Item no.	<a href="#">2800419</a>	<a href="#">2800531</a>

# Application-related protection

## Type 2 surge protection for stable 240/415 V systems

			
<b>Number of positions</b>	<b>4-pos.</b> <span style="background-color: #e91e63; color: white; padding: 2px;">NEW</span>	<b>2-pos.</b> <span style="background-color: #e91e63; color: white; padding: 2px;">NEW</span>	<b>1-pos.</b> <span style="background-color: #e91e63; color: white; padding: 2px;">NEW</span>
Nominal voltage	240/415 V AC (TN-S) 240/415 V AC (TT)	240/415 V AC (TN-S) 240/415 V AC (TT)	240 V AC (TN) 240 V AC (TT)
Type in accordance with IEC	T2	T2	T2
Maximum continuous operating voltage $U_c$	275 V AC (L-N) 305 V AC (N-PE)	275 V AC (L-N) 305 V AC (N-PE)	275 V AC
Voltage protection level	$\leq 1.35$ kV (L-N) $\leq 1.5$ kV (N-PE)	$\leq 1.35$ kV (L-N) $\leq 1.5$ kV (N-PE)	$\leq 1.35$ kV
Max. backup fuse F2	315 A (gG)	315 A (gG)	315 A (gG)
Approvals	DNV  	DNV  	DNV  
Nominal discharge current	20 kA	20 kA	20 kA
Type	VAL-SPP-T2-275-3+1-UT-R	VAL-SPP-T2-275-1+1-UT-R	VAL-SPP-T2-275-1+0-UT-R
Item no.	<a href="#">1466214</a>	<a href="#">1466212</a>	<a href="#">1466210</a>

## Type 2 surge protection for unstable 240/415 V systems

		
<b>Number of positions</b>	<b>4-pos.</b> <span style="background-color: #e91e63; color: white; padding: 2px;">NEW</span>	<b>2-pos.</b> <span style="background-color: #e91e63; color: white; padding: 2px;">NEW</span>
Nominal voltage	240/415 V AC (TN-S) 240/415 V AC (TT)	240/415 V AC (TN-S) 240/415 V AC (TT)
Type in accordance with IEC	T2	T2
Maximum continuous operating voltage $U_c$	335 V AC (L-N) 305 V AC (N-PE)	335 V AC (L-N) 305 V AC (N-PE)
Voltage protection level	$\leq 1.5$ kV (L-N) $\leq 1.5$ kV (N-PE)	$\leq 1.5$ kV (L-N) $\leq 1.5$ kV (N-PE)
Max. backup fuse F2	315 A (gG)	315 A (gG)
Approvals	DNV  	DNV  
Nominal discharge current	20 kA	20 kA
Type	VAL-SPP-T2-335-3+1-UT-R	VAL-SPP-T2-335-1+1-UT-R
Item no.	<a href="#">1466604</a>	<a href="#">1466597</a>

# Application-related protection

Surge protection for 24 V DC and 48 V DC applications		
		
<b>Number of positions</b>	<b>1-pos.</b>	<b>2-pos.</b>
Nominal voltage	60 V AC (TN)	60 V AC (TN-S)
Type in accordance with IEC	T2	T1 / T2
Maximum continuous operating voltage $U_c$	75 V AC	75 V AC
Voltage protection level	$\leq 0.55$ kV	$\leq 0.8$ kV (L-PE) $\leq 0.4$ kV (L-N) $\leq 0.4$ kV (N-PE)
Max. backup fuse F2	125 A AC (gG)	160 A (gG)
Approvals		
Nominal discharge current	15 kA	12.5 kA
Lightning impulse current	-	12.5 kA
Type	VAL-MS 60/FM	VAL-MS-T1/T2 48/12.5/1+1V-FM
Item no.	<a href="#">2868033</a>	<a href="#">2801533</a>

## Application-related protection

### Type 2 surge protection with high electric strength

COMPLETE line







<b>Number of positions</b>	<b>1-pos.</b>	<b>NEW</b>
Nominal voltage	240 V AC (TN) 240 V AC (TT) 230 V AC (IT)	
Type in accordance with IEC	T2	
Maximum continuous operating voltage $U_c$	350 V AC	
Voltage protection level	$\leq 1.5$ kV	
Max. backup fuse F2	200 A (gG)	
Approvals	DNV 	
Nominal discharge current	20 kA	
Type	VAL-SPP-T2-350-1VF+0-UT-R	
Item no.	1466640	

### Type 2 surge protection for 400/690 V and 400 V IT systems











COMPLETE line







<b>Number of positions</b>	<b>3-pos.</b>	<b>NEW</b>	<b>3-pos.</b>	<b>NEW</b>
Nominal voltage	554/960 V AC (TN-C) 690 V AC (IT)		400/690 V AC (TN-C)	
Type in accordance with IEC	T2		T2	
Maximum continuous operating voltage $U_c$	760 V AC		440 V AC	
Voltage protection level	$\leq 3$ kV		$\leq 2.1$ kV	
Max. backup fuse F2	250 A (gG)		315 A (gG)	
Approvals	DNV  		DNV  	
Nominal discharge current	20 kA		20 kA	
Type	VAL-SPP-T2-750-3+0-UT-R		VAL-SPP-T2-440-3+0-UT-R	
Item no.	1466614		1466615	

# Application-related protection

## Type 2 surge protection with coordinated backup fuse





					
<b>Number of positions</b>	<b>2-pos.</b>	<b>3-pos.</b>	<b>4-pos.</b>	<b>4-pos.</b>	<b>3-pos.</b>
Nominal voltage	240 V AC (TN-S) 240 V AC (TT)	240/415 V AC (TN-C)	240/415 V AC (TN-S) 240/415 V AC (TT)	240/415 V AC (TN-S) 240/415 V AC (TT)	240/415 V AC (TN-C) 240/415 V AC (TT)
Type in accordance with IEC	T2	T2	T2	T2	T2
Maximum continuous operating voltage $U_c$	350 V AC (L-N) 264 V AC (N-PE)	350 V AC	350 V AC (L-N) 264 V AC (N-PE)	350 V AC (L-N) 264 V AC (N-PE)	350 V AC
Voltage protection level	$\leq 2.5$ kV (L-N) $\leq 1.7$ kV (N-PE)	$\leq 2.5$ kV	$\leq 2.5$ kV (L-N) $\leq 1.7$ kV (N-PE)	$\leq 2.5$ kV (L-N) $\leq 1.5$ kV (N-PE)	$\leq 2.5$ kV
Approvals					
Nominal discharge current	15 kA (L-N) 20 kA (N-PE)	15 kA	15 kA (L-N) 20 kA (N-PE)	20 kA	20 kA
Type	VAL-CP-MCB-1S-350/40/FM	VAL-CP-MCB-3C-350/40/FM	VAL-CP-MCB-3S-350/40/FM	VAL-CP-MOSO 60-3S-FM	VAL-CP-MOSO 60-3C-FM
Item no.	<a href="#">2882763</a>	<a href="#">2882776</a>	<a href="#">2882750</a>	<a href="#">2804403</a>	<a href="#">2804416</a>

## Surge protection for linear DC grids







			
<b>Number of positions</b>	<b>2-pos.</b>	<b>NEW</b>	<b>2-pos.</b>
Nominal voltage	1000 V DC		750 V DC
Type in accordance with IEC	T1 / T2		T2
Maximum continuous operating voltage $U_c$	1000 V DC		800 V DC
Voltage protection level	$\leq 4.5$ kV		$\leq 3.3$ kV
Max. backup fuse F2	80 A (gG at $I_{SCCR} > 800$ A DC)		40 A (gG / 1200 V DC)
Nominal discharge current	20 kA		20 kA
Type	VAL-MB-T1/T2-1000DC-2+V-R		VAL-MB-T2-750DC-2+V-R
Item no.	<a href="#">1683780</a>		<a href="#">1376160</a>
			<a href="#">1376162</a>

# Application-related protection







## Type 1+2 combined lightning current and surge arresters for photovoltaics







		
<b>Number of positions</b>	<b>3-pos.</b> <span style="background-color: #e91e63; color: white; padding: 2px;">NEW</span>	<b>2-pos.</b>
Type in accordance with IEC	T1 / T2	T1 / T2
Maximum continuous operating voltage $U_c$	1200 V DC	1500 V DC
Voltage protection level	$\leq 4.2$ kV	$\leq 4.5$ kV
Approvals		
Nominal discharge current	20 kA	20 kA
Lightning impulse current	5 kA	6.25 kA
Type	VAL-SPP-T1-1000DC-PV-2+V-UT-R	VAL-MB-T1/T2 1500DC-PV/2+V-FM
Item no.	<a href="#">1466777</a>	<a href="#">2905640</a>

## Type 2 surge protection for photovoltaics

			
<b>Number of positions</b>	<b>3-pos.</b> <span style="background-color: #e91e63; color: white; padding: 2px;">NEW</span>	<b>3-pos.</b> <span style="background-color: #e91e63; color: white; padding: 2px;">NEW</span>	<b>3-pos.</b> <span style="background-color: #e91e63; color: white; padding: 2px;">NEW</span>
Type in accordance with IEC	T2	T2	T2
Maximum continuous operating voltage $U_c$	800 V DC	1200 V DC	1800 V DC
Voltage protection level	$\leq 3$ kV	$\leq 4.2$ kV	$\leq 5.7$ kV
Approvals			
Nominal discharge current	20 kA	20 kA	20 kA
Type	VAL-SPP-T2-600DC-PV-2+V-UT-R	VAL-SPP-T2-1000DC-PV-2+V-UT-R	VAL-SPP-T2-1500DC-PV-2+V-UT-R
Item no.	<a href="#">1466771</a>	<a href="#">1466773</a>	<a href="#">1466775</a>

# Application-related protection

Type 2 surge protection for stators and rotors		
		
<b>Number of positions</b>	<b>3-pos.</b> <span style="background-color: #e91e63; color: white; padding: 2px;">NEW</span>	<b>2-pos.</b> <span style="background-color: #e91e63; color: white; padding: 2px;">NEW</span>
Nominal voltage	554/960 V AC (TN-C) 690 V AC (IT)	800 V AC (IT)
Type in accordance with IEC	T2	T2
Maximum continuous operating voltage $U_c$	760 V AC	880 V AC
Voltage protection level	$\leq 3$ kV	$\leq 4.5$ kV
Max. backup fuse F2	250 A (gG)	250 A (gG)
Approvals	DNV  CB 	DNV  CB 
Nominal discharge current	20 kA	20 kA
Type	VAL-SPP-T2-750-3+0-UT-R	VAL-SPP-T2-800WE-3+0-VF-UT-R
Item no.	<a href="#">1466614</a>	<a href="#">1466642</a>

Type 2 surge protection for LED applications		
		
<b>Nominal voltage</b>	100 V AC ... 277 V AC	100 V AC ... 277 V AC (TN-S) 100 V AC ... 277 V AC (TT)
Type in accordance with IEC	T2 / T3	T2 / T3
Maximum continuous operating voltage $U_c$	320 V AC	320 V AC (L-N) 305 V AC (N-PE)
Voltage protection level	$\leq 1.3$ kV	$\leq 1.3$ kV (L-N) $\leq 1.4$ kV (N-PE)
Max. backup fuse F2	16 A (MCB B/C)	16 A (MCB B/C)
Approvals	KEUR  CB 	KEUR  CB 
Nominal discharge current	5 kA	5 kA (L-N) 10 kA (N-PE)
Type	BLT-T2-320-UT	BLT-T2-1S-320-UT
Item no.	<a href="#">2906100</a>	<a href="#">2906101</a>

Surge protection for power supplies

## UL-compliant surge protection

### For North American supply systems

Separate safety and testing requirements in accordance with UL 1449 for the North American market. Systems that are operated in North America and subject to the NEMA (National Electrical Manufacturers Association) regulations require special UL-listed surge protective devices.

The VAL-US-SPP products are UL Type 1 Listed and therefore fulfill the requirements of UL 1449. They ensure that installations can be reliably tested, approved, and permanently operated in compliance with standards.



### Your advantages









- ✓ Easy integration into existing applications with Open Type UL Listed
- ✓ Available for all standard network configurations according to NEMA
- ✓ Available throughout Europe and can be used throughout Europe thanks to CE conformity
- ✓ Easy system status monitoring with an optical status indicator and remote indication contact

# UL-compliant surge protection









1  
2  
3  
4  
5

Surge protection for power supplies









## UL-listed type 1 surge protection – circuit version 1+0





				
<b>Number of positions</b>	<b>1-pos.</b> <b>NEW</b>	<b>1-pos.</b> <b>NEW</b>	<b>1-pos.</b> <b>NEW</b>	<b>1-pos.</b> <b>NEW</b>
Nominal voltage $U_N$	120 V AC	120 V AC	240 V AC	277 V AC
Type in accordance with UL	1	1	1	1
Maximum continuous voltage MCOV	175 V AC	175 V AC	385 V AC	385 V AC
Short-circuit current rating (SCCR)	200 kA	200 kA	200 kA	200 kA
Voltage protection rating VPR	700 V	700 V	1500 V	1500 V
Approvals				
Nominal discharge current $I_n$	20 kA	20 kA	20 kA	20 kA
Maximum surge current per phase	50 kA	65 kA	50 kA	50 kA
Type	VAL-US-SPP-120/50/1+0-R	VAL-US-SPP-120/65/1+0-R	VAL-US-SPP-240/50/1+0-R	VAL-US-SPP-277/50/1+0-R
Item no.	1790744	1790752	1790763	1790770

## UL-listed type 1 surge protection – circuit version 1+1







				
<b>Number of positions</b>	<b>2-pos.</b> <b>NEW</b>	<b>2-pos.</b> <b>NEW</b>	<b>2-pos.</b> <b>NEW</b>	<b>2-pos.</b> <b>NEW</b>
Nominal voltage $U_N$	120 V AC	120 V AC	240 V AC	277 V AC
Type in accordance with UL	1	1	1	1
Maximum continuous voltage MCOV	175 V AC (L-N) 175 V AC (L-G) 305 V AC (N-G)	175 V AC (L-N) 175 V AC (L-G) 305 V AC (N-G)	385 V AC (L-N) 385 V AC (L-G) 305 V AC (N-G)	385 V AC (L-N) 385 V AC (L-G) 305 V AC (N-G)
Short-circuit current rating (SCCR)	200 kA	200 kA	200 kA	200 kA
Voltage protection rating VPR	700 V (L-N) 900 V (L-G) 900 V (N-G)	700 V (L-N) 900 V (L-G) 900 V (N-G)	1500 V (L-N) 1500 V (L-G) 900 V (N-G)	1500 V (L-N) 1500 V (L-G) 900 V (N-G)
Approvals				
Nominal discharge current $I_n$	20 kA	20 kA	20 kA	20 kA
Maximum surge current per phase	50 kA	65 kA	50 kA	50 kA
Type	VAL-US-SPP-120/50/1+1-R	VAL-US-SPP-120/65/1+1-R	VAL-US-SPP-240/50/1+1-R	VAL-US-SPP-277/50/1+1-R
Item no.	1790745	1790753	1790764	1790772





# UL-compliant surge protection

UL-listed type 1 surge protection – circuit version 2+0				
				
<b>Number of positions</b>	<b>2-pos.</b> <span style="background-color: #e91e63; color: white; padding: 2px;">NEW</span>	<b>2-pos.</b> <span style="background-color: #e91e63; color: white; padding: 2px;">NEW</span>	<b>2-pos.</b> <span style="background-color: #e91e63; color: white; padding: 2px;">NEW</span>	<b>2-pos.</b> <span style="background-color: #e91e63; color: white; padding: 2px;">NEW</span>
Nominal voltage $U_N$	120/240 V AC (split phase)	120/240 V AC (split phase)	240/480 V AC (split phase)	240 V AC (Delta)
Type in accordance with UL	1	1	1	1
Maximum continuous voltage MCOV	350 V AC (L-L) 175 V AC (L-G)	350 V AC (L-L) 175 V AC (L-G)	770 V AC (L-L) 385 V AC (L-G)	550 V AC (L-L) 275 V AC (L-G)
Short-circuit current rating (SCCR)	200 kA	200 kA	200 kA	200 kA
Voltage protection rating VPR	1200 V (L-L) 700 V (L-G)	1200 V (L-L) 700 V (L-G)	2500 V (L-L) 1500 V (L-G)	1800 V (L-L) 1000 V (L-G)
Approvals				
Nominal discharge current $I_n$	20 kA	20 kA	20 kA	20 kA
Maximum surge current per phase	50 kA	65 kA	50 kA	65 kA
Type	VAL-US-SPP-120/50/2+0-R	VAL-US-SPP-120/65/2+0-R	VAL-US-SPP-240/50/2+0-R	VAL-US-SPP-240D/65/2+0-R
Item no.	1790747	1790754	1790765	1790786

UL-listed type 1 surge protection – circuit version 2+1		
		
<b>Number of positions</b>	<b>3-pos.</b> <span style="background-color: #e91e63; color: white; padding: 2px;">NEW</span>	<b>3-pos.</b> <span style="background-color: #e91e63; color: white; padding: 2px;">NEW</span>
Nominal voltage $U_N$	120/208 V AC (wye) 120/240 V AC (split phase)	120/240 V AC (wye) 120/208 V AC (split phase)
Type in accordance with UL	1	1
Maximum continuous voltage MCOV	350 V AC (L-L) 175 V AC (L-N) 175 V AC (L-G) 305 V AC (N-G)	350 V AC (L-L) 175 V AC (L-N) 175 V AC (L-G) 305 V AC (N-G)
Short-circuit current rating (SCCR)	200 kA	200 kA
Voltage protection rating VPR	1200 V (L-L) 700 V (L-N) 900 V (L-G) 900 V (N-G)	1200 V (L-L) 700 V (L-N) 900 V (L-G) 900 V (N-G)
Approvals		
Nominal discharge current $I_n$	20 kA	20 kA
Maximum surge current per phase	50 kA	65 kA
Type	VAL-US-SPP-120/50/2+1-R	VAL-US-SPP-120/65/2+1-R
Item no.	1790748	1790756







# UL-compliant surge protection

UL-listed type 1 surge protection – circuit version 3+0 (wye – N and G combined)			
			
<b>Number of positions</b>	<b>3-pos.</b> <b>NEW</b>	<b>3-pos.</b> <b>NEW</b>	<b>3-pos.</b> <b>NEW</b>
Nominal voltage $U_N$	120/208 V AC (wye) 120/240 V AC (split phase)	120/208 V AC (wye) 120/240 V AC (split phase)	240/415 V AC (wye)
Type in accordance with UL	1	1	1
Maximum continuous voltage MCOV	350 V AC (L-L) 175 V AC (L-G)	350 V AC (L-L) 175 V AC (L-G)	770 V AC (L-L) 385 V AC (L-G)
Short-circuit current rating (SCCR)	200 kA	200 kA	200 kA
Voltage protection rating VPR	1200 V (L-L) 700 V (L-G)	1200 V (L-L) 700 V (L-G)	2500 V (L-L) 1500 V (L-G)
Approvals			
Nominal discharge current $I_n$	20 kA	20 kA	20 kA
Maximum surge current per phase	50 kA	65 kA	50 kA
Type	VAL-US-SPP-120/50/3+0-R	VAL-US-SPP-120/65/3+0-R	VAL-US-SPP-240/50/3+0-R
Item no.	<a href="#">1790749</a>	<a href="#">1790758</a>	<a href="#">1790766</a>





			
<b>Number of positions</b>	<b>3-pos.</b> <b>NEW</b>	<b>3-pos.</b> <b>NEW</b>	<b>3-pos.</b> <b>NEW</b>
Nominal voltage $U_N$	277/480 V AC (wye)	277/480 V AC (wye)	400/690 V AC (wye) 347/600 V AC (wye)
Type in accordance with UL	1	1	1
Maximum continuous voltage MCOV	770 V AC (L-L) 385 V AC (L-G)	770 V AC (L-L) 385 V AC (L-G)	1100 V AC (L-L) 550 V AC (L-G)
Short-circuit current rating (SCCR)	200 kA	200 kA	200 kA
Voltage protection rating VPR	2500 V (L-L) 1500 V (L-G)	2500 V (L-L) 1500 V (L-G)	4000 V (L-L) 2000 V (L-G)
Approvals			
Nominal discharge current $I_n$	20 kA	20 kA	20 kA
Maximum surge current per phase	50 kA	65 kA	40 kA
Type	VAL-US-SPP-277/50/3+0-R	VAL-US-SPP-277/65/3+0-R	VAL-US-SPP-400/40/3+0-R
Item no.	<a href="#">1790773</a>	<a href="#">1790778</a>	<a href="#">1790783</a>

# UL-compliant surge protection

## UL-listed type 1 surge protection – circuit version 3+0 (ungrounded Delta)

			
<b>Number of positions</b>	<b>3-pos.</b> <span style="background-color: #e91e63; color: white; padding: 2px;">NEW</span>	<b>3-pos.</b> <span style="background-color: #e91e63; color: white; padding: 2px;">NEW</span>	<b>3-pos.</b> <span style="background-color: #e91e63; color: white; padding: 2px;">NEW</span>
Nominal voltage $U_N$	240 V AC (Delta)	480 V AC (Delta)	600 V AC (Delta)
Type in accordance with UL	1	1	1
Maximum continuous voltage MCOV	550 V AC (L-L) 275 V AC (L-G)	1100 V AC (L-L) 550 V AC (L-G)	1500 V AC (L-L) 750 V AC (L-G)
Short-circuit current rating (SCCR)	200 kA	200 kA	200 kA
Voltage protection rating VPR	1800 V (L-L) 1000 V (L-G)	1800 V (L-L) 2000 V (L-G)	5000 V (L-L) 2500 V (L-G)
Approvals			
Nominal discharge current $I_n$	20 kA	20 kA	20 kA
Maximum surge current per phase	65 kA	40 kA	40 kA
Type	VAL-US-SPP-240D/65/3+0-R	VAL-US-SPP-480D/40/3+0-R	VAL-US-SPP-600D/40/3+0-R
Item no.	<a href="#">1790787</a>	<a href="#">1790790</a>	<a href="#">1790793</a>







## UL-listed type 1 surge protection – circuit version 3+1 (high-leg Delta)







		
<b>Number of positions</b>	<b>4-pos.</b> <span style="background-color: #e91e63; color: white; padding: 2px;">NEW</span>	<b>4-pos.</b> <span style="background-color: #e91e63; color: white; padding: 2px;">NEW</span>
Nominal voltage $U_N$	120/240 V AC	240/480 V AC
Type in accordance with UL	1	1
Maximum continuous voltage MCOV	350 V AC (450 V AC (HL-L)) (L-L) 175 V AC (275 V AC (HL-N)) (L-N) 175 V AC (275 V AC (HL-N)) (L-G) 305 V AC (N-G)	550 V AC (L-L) 275 V AC (L-N) 275 V AC (550 V AC (HL-G)) (L-G) 440 V AC (N-G)
Short-circuit current rating (SCCR)	200 kA	200 kA
Voltage protection rating VPR	1200 V (L-L) 700 V (L-N) 900 V (L-G) 900 V (N-G)	1800 V (L-L) 1000 V (L-N) 1500 V (L-G) 1500 V (N-G)
Approvals		
Nominal discharge current $I_n$	20 kA	20 kA
Maximum surge current per phase	65 kA	40 kA
Type	VAL-US-SPP-240HLD/65/3+1-R	VAL-US-SPP-480HLD/40/3+1-R
Item no.	<a href="#">1790794</a>	<a href="#">1790795</a>

# UL-compliant surge protection





1  
2  
3  
4  
5

Surge protection for power supplies





UL-listed type 1 surge protection – circuit version 3+1 (wye)			
			
<b>Number of positions</b>	<b>4-pos.</b> <b>NEW</b>	<b>4-pos.</b> <b>NEW</b>	<b>4-pos.</b> <b>NEW</b>
Nominal voltage $U_N$	120/208 V AC (wye)	120/208 V AC (wye)	240/415 V AC (wye)
Type in accordance with UL	1	1	1
Maximum continuous voltage MCOV	350 V AC (L-L) 175 V AC (L-N) 175 V AC (L-G) 305 V AC (N-G)	350 V AC (L-L) 175 V AC (L-N) 175 V AC (L-G) 305 V AC (N-G)	770 V AC (L-L) 385 V AC (L-G) 305 V AC (N-G)
Short-circuit current rating (SCCR)	200 kA	200 kA	200 kA
Voltage protection rating VPR	1200 V (L-L) 700 V (L-N) 900 V (L-G) 900 V (N-G)	1200 V (L-L) 700 V (L-N) 900 V (L-G) 900 V (N-G)	2500 V (L-L) 1500 V (L-N) 1500 V (L-G) 900 V (N-G)
Approvals			
Nominal discharge current $I_n$	20 kA	20 kA	20 kA
Maximum surge current per phase	50 kA	65 kA	50 kA
Type	VAL-US-SPP-120/50/3+1-R	VAL-US-SPP-120/65/3+1-R	VAL-US-SPP-240/50/3+1-R
Item no.	1790750	1790760	1790767

			
<b>Number of positions</b>	<b>4-pos.</b> <b>NEW</b>	<b>4-pos.</b> <b>NEW</b>	<b>4-pos.</b> <b>NEW</b>
Nominal voltage $U_N$	277/480 V AC (wye)	277/480 V AC (wye)	400/690 V AC (wye) 347/600 V AC (wye)
Type in accordance with UL	1	1	1
Maximum continuous voltage MCOV	770 V AC (L-L) 385 V AC (L-N) 385 V AC (L-G) 305 V AC (N-G)	770 V AC (L-L) 385 V AC (L-N) 385 V AC (L-G) 305 V AC (N-G)	1100 V AC (L-L) 550 V AC (L-N) 550 V AC (L-G) 440 V AC (N-G)
Short-circuit current rating (SCCR)	200 kA	200 kA	200 kA
Voltage protection rating VPR	2500 V (L-L) 1500 V (L-N) 1500 V (L-G) 900 V (N-G)	2500 V (L-L) 1500 V (L-N) 1500 V (L-G) 900 V (N-G)	4000 V (L-L) 2000 V (L-N) 3000 V (L-G) 1500 V (N-G)
Approvals			
Nominal discharge current $I_n$	20 kA	20 kA	20 kA
Maximum surge current per phase	50 kA	65 kA	40 kA
Type	VAL-US-SPP-277/50/3+1-R	VAL-US-SPP-277/65/3+1-R	VAL-US-SPP-400/40/3+1-R
Item no.	1790774	1790779	1790785

# UL-compliant surge protection

UL-listed type 1 surge protection – circuit version 4+0 (wye)		
		
<b>Number of positions</b>	<b>4-pos.</b> <span style="background-color: #e91e63; color: white; padding: 2px;">NEW</span>	<b>4-pos.</b> <span style="background-color: #e91e63; color: white; padding: 2px;">NEW</span>
Nominal voltage $U_N$	277/480 V AC (wye)	277/480 V AC (wye)
Type in accordance with UL	1	1
Maximum continuous voltage MCOV	770 V AC (L-L) 385 V AC (L-N) 385 V AC (L-G) 385 V AC (N-G)	770 V AC (L-L) 385 V AC (L-N) 385 V AC (L-G) 385 V AC (N-G)
Short-circuit current rating (SCCR)	200 kA	200 kA
Voltage protection rating VPR	2500 V (L-L) 2500 V (L-N) 1500 V (L-G) 1500 V (N-G)	2500 V (L-L) 2500 V (L-N) 1500 V (L-G) 1500 V (N-G)
Approvals		
Nominal discharge current $I_n$	20 kA	20 kA
Maximum surge current per phase	50 kA	65 kA
Type	VAL-US-SPP-277/50/4+0-R	VAL-US-SPP-277/65/4+0-R
Item no.	<a href="#">1790776</a>	<a href="#">1790781</a>

# UL-compliant surge protection

Surge protection for 24 V DC and 48 V DC applications – UL-listed		
		
<b>Number of positions</b>	<b>1-pos.</b>	<b>2-pos.</b>
Nominal voltage $U_N$	48 V DC	48 V DC
Type in accordance with UL	1	1
Maximum continuous voltage MCOV	100 V DC	100 V DC ((DC+)-(DC-)) 100 V DC ((DC+)-G) 100 V DC ((DC-)-G)
Short-circuit current rating (SCCR)	5 kA	5 kA (DC)
Voltage protection rating VPR	400 V	400 V ((DC+)-(DC-)) 400 V ((DC+)-G) 600 V ((DC-)-G)
Approvals		
Nominal discharge current $I_n$	20 kA	20 kA
Maximum surge current per phase	65 kA	65 kA
Type	VAL-US-48/65/1+0-FM	VAL-US-48/65/1+1V-FM
Item no.	<a href="#">2910345</a>	<a href="#">2910346</a>

## Reliable protection for modern systems

### Secure end device protection for industry and buildings

Robust industrial processes and modern building automation systems require the reliable protection of sensitive end devices against surges. Type 3 surge protection supplements existing type 2 installations and ensures that control systems, sensors, and smart home technology continue to work undisturbed even during transient events.



#### Your advantages

- ✔ Variable in installation with different designs
- ✔ Powerful protection for AC and DC applications enables use in a variety of applications
- ✔ Disconnect device provides increased safety in case of electrical and thermal overload

# Device protection for different applications

## Surge protection and power supply for high system availability

For extreme operating conditions, use the optimally coordinated combination of PLUGTRAB-SEC surge protection and powerful 4th generation QUINT POWER power supply.

### Higher current carrying capacity

Using harmonized surge protective components enables symmetrical current distribution when overvoltage occurs.

### Up to ten times higher protection

By using the type 3 PLT-SEC surge protective device, the QUINT POWER 4th generation power supply is ten times better able to withstand surge currents than it would be without the protection.

### Double the life expectancy

A comparison with uncoordinated products shows that our combination of PLT-SEC surge protection and QUINT POWER 4th generation power supply doubles the power supply's life expectancy.

### 5-year warranty

If your 4th generation QUINT POWER becomes damaged in the first five years following purchase despite using this combination, you will receive a free replacement.

For further information and conditions, see our website at:

[phoenixcontact.com/perfectteam](http://phoenixcontact.com/perfectteam)

- Overview of the PLT-SEC type 3 products:  
More information starting on page 44



*A strong team combining surge protection and a power supply*

## Surge protection for I/Os and controllers

Based on the 6 mm wide TERMITRAB complete range, the TTC type 3 protects the 24 V power supplies of end devices such as I/Os and controllers against surge voltages from the field.





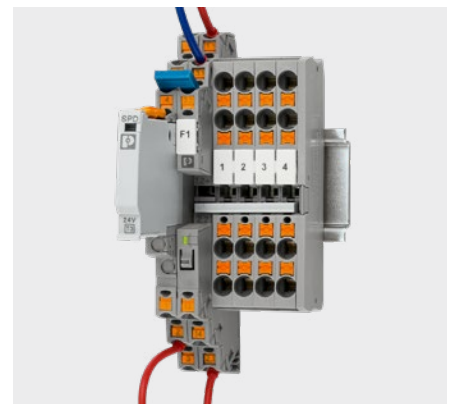





Moreover, the TTC type 3 can be used to protect a potential distribution system from the CLIPLINE complete terminal block program and PTCB device circuit breakers directly against surge voltages. Of the same contour as the TTC type 3, the PTCB electronic circuit breakers are the ideal overcurrent protection for your end devices.

- You will find more information on electronic circuit breakers at: [phoenixcontact.com/electronic-circuit-breakers](http://phoenixcontact.com/electronic-circuit-breakers)













*Protect potential distribution systems directly against surge voltages.*

# Protection directly at the end device

Type 3 device protection with Push-in connection					
					
<b>Number of positions</b>	<b>2-pos.</b>	<b>2-pos.</b>	<b>2-pos.</b>	<b>2-pos.</b>	<b>2-pos.</b>
Nominal voltage	24 V DC	24 V AC (TN-S)	60 V AC (TN-S)	120 V AC (TN-S) 120 V AC (TT)	240 V AC (TN-S) 240 V AC (TT)
Type in accordance with IEC	T3	T3	T3	T2 / T3	T2 / T3
Maximum continuous operating voltage $U_c$	30 V DC	34 V AC	80 V AC	150 V AC	264 V AC
Voltage protection level	$\leq 0.09$ kV ( $U_{oc} = 2$ kV) $\leq 0.2$ kV ( $U_{oc} = 6$ kV) (DC-DC) $\leq 0.7$ kV (DC-PE)	$\leq 0.2$ kV (L-N) $\leq 0.6$ kV (N-PE)	$\leq 0.48$ kV (L-N) $\leq 0.8$ kV (N-PE)	$\leq 0.75$ kV (L-N) $\leq 0.85$ kV (N-PE)	$\leq 1.25$ kV (L-N) $\leq 1.4$ kV (N-PE)
Max. backup fuse F2	6 A (gG)	32 A (gG / B / C)	32 A (gG / B / C)	32 A (gG / B / C)	32 A (gG / B / C)
Approvals					
Nominal discharge current	1 kA	1 kA	2 kA	5 kA	5 kA
Combined surge	2 kV (2 $\Omega$ )	2 kV	4 kV	6 kV	6 kV
Type	TTC-6P-T3-24DC-PT-I	PLT-SEC-T3-24-FM-PT	PLT-SEC-T3-60-FM-PT	PLT-SEC-T3-120-FM-PT	PLT-SEC-T3-230-FM-PT
Item no.	1027586	2907925	2907926	2907927	2907928

# Protection directly at the end device

Type 3 device protection with screw connection					
					
<b>Number of positions</b>	<b>2-pos.</b>	<b>2-pos.</b>	<b>2-pos.</b>	<b>2-pos.</b>	<b>2-pos.</b>
Nominal voltage	24 V DC	24 V AC (TN-S)	60 V AC (TN-S)	120 V AC (TN-S) 120 V AC (TT)	240 V AC (TN-S) 240 V AC (TT)
Type in accordance with IEC	T3	T3	T3	T2 / T3	T2 / T3
Maximum continuous operating voltage $U_c$	30 V DC	34 V AC	80 V AC	150 V AC	264 V AC
Voltage protection level	$\leq 0.09$ kV ( $U_{oc} = 2$ kV) $\leq 0.2$ kV ( $U_{oc} = 6$ kV) (DC-DC) $\leq 0.7$ kV (DC-PE)	$\leq 0.2$ kV (L-N) $\leq 0.6$ kV (N-PE)	$\leq 0.48$ kV (L-N) $\leq 0.8$ kV (N-PE)	$\leq 0.75$ kV (L-N) $\leq 0.85$ kV (N-PE)	$\leq 1.25$ kV (L-N) $\leq 1.4$ kV (N-PE)
Max. backup fuse F2	6 A (gG)	32 A (gG / B / C)	32 A (gG / B / C)	32 A (gG / B / C)	32 A (gG / B / C)
Approvals		DNV 	DNV 	DNV 	DNV 
Nominal discharge current	1 kA	1 kA	2 kA	5 kA	5 kA
Combined surge	2 kV (2 $\Omega$ )	2 kV	4 kV	6 kV	6 kV
Type	TTC-6P-T3-24DC-UT-I	PLT-SEC-T3-24-FM-UT	PLT-SEC-T3-60-FM-UT	PLT-SEC-T3-120-FM-UT	PLT-SEC-T3-230-FM-UT
Item no.	<a href="#">1027584</a>	<a href="#">2907916</a>	<a href="#">2907917</a>	<a href="#">2907918</a>	<a href="#">2907919</a>

# Surge protection and power supplies

## The perfect team for high system availability

Combine our products to create an overall concept and benefit from the advantages of system integration.

Systems are precisely clocked – one component fails, and system downtimes occur. Surge voltages, mains interruptions, or fluctuations as well as an overload or short circuit can severely impact your system. High availability requires coordinated components that not only supply, but also protect.



### Your advantages

- ✔ Surge protection for protection concepts in every application
- ✔ Device circuit breaker for protection against overload and short circuit
- ✔ Failsafe and reliable through coordinated components
- ✔ Individual expansion with the comprehensive product portfolio

### Further information on surge protection and device protection

Simply scan the QR code or enter the web code into the search field on our website.

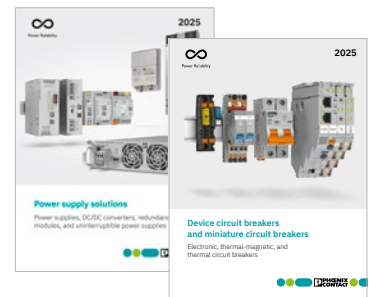

#### Power supplies



Web code:  
#0151

#### Device protection



Web code:  
#0156

# Protection for high system availability

Our products for the operational safety of electrical systems, installations, and devices enable you to effortlessly create an uninterruptible and clean power supply, as well as a stable data connection. Increasing demand for high quality and efficiency in production is leading

to the construction of increasingly complex systems. At the same time, the requirements on safety and availability are increasing. The failure of machines or larger system parts results in significant costs.

With our coordinated product portfolio for power supplies and coordinated protective devices, a protection concept can be created for any application.



### Power supplies, DC/DC converters, redundancy modules, and uninterruptible power supplies

- Power supplies for the reliable supply of your system, with various designs, performance classes, and functions
- DC/DC converters for a regulated direct voltage, with long cable lengths
- Redundancy, UPS, and battery modules for decoupling power supply units connected in parallel as well as for uninterrupted system operation of DC and AC loads

### Device circuit breakers for different requirements:

- Electronic circuit breakers for protection in the event of overload, short circuit, line attenuation, and high input capacitance
- Thermal-magnetic circuit breakers for protection in the event of overload and short circuit
- Thermal circuit breakers for protection in the event of overload

## The protected system

Components that work together perfectly are needed to ensure permanently high system availability. This is exactly where the powerful team of PLUGTRAB-SEC surge protection and QUINT POWER power supplies comes in. Both technologies are optimally matched to each other. They offer maximum safety even under high EMC loads and in harsh environments. The symmetrical current distribution increases the load capacity of the power supply tenfold and doubles its service life. This reliably prevents unplanned downtime, stabilizes production processes, and creates planning security. This combination makes the duo the ideal solution for demanding applications where protection, efficiency, and availability are paramount.

You will find more product combinations with added value at:

[phoenixcontact.com/perfectteam](http://phoenixcontact.com/perfectteam)

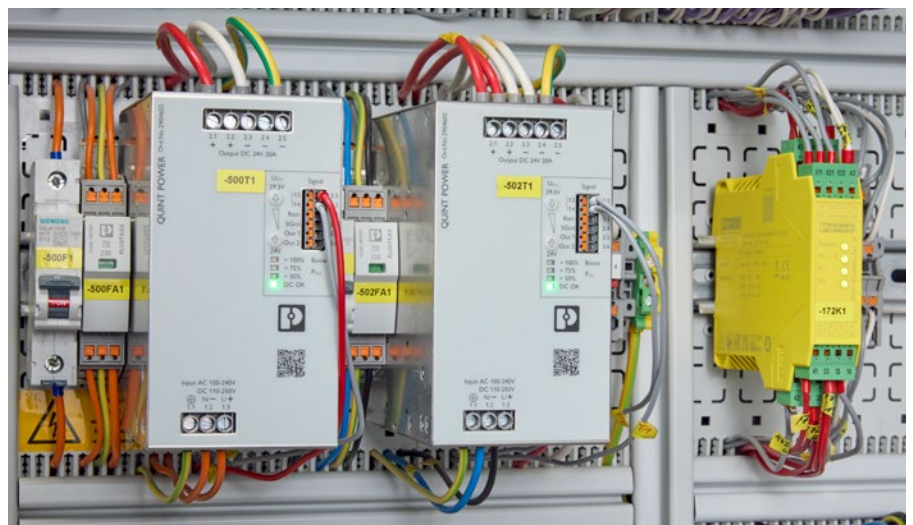

# Surge protection for measurement and control technology

## Interference-free signal transmission guaranteed

The interfaces in measurement and control technology are particularly sensitive. Even low surge voltages have the potential to disrupt smooth operation of the building control technology, production, and process technology. Surge protection systems specially tailored to the requirements enable the interference-free transmission of signals.

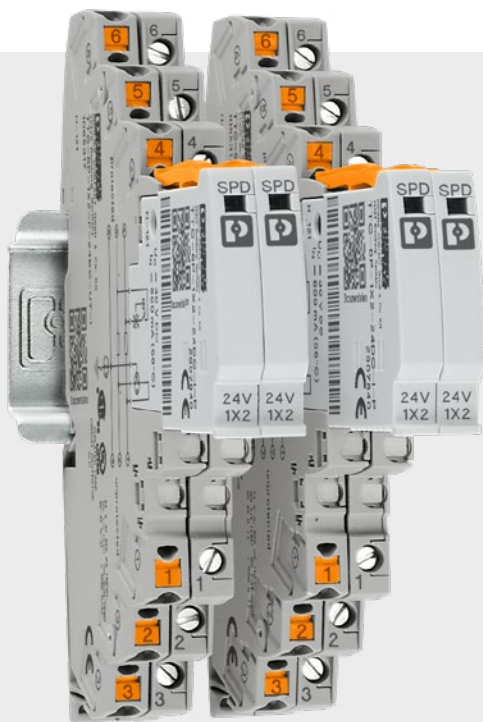

### Compact for every application

TERMITRAB complete – surge protection with an overall width starting at 3.5 mm for applications in the extra-low-voltage range with a selectable range of functions.

➤ More information starting on page 52

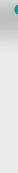
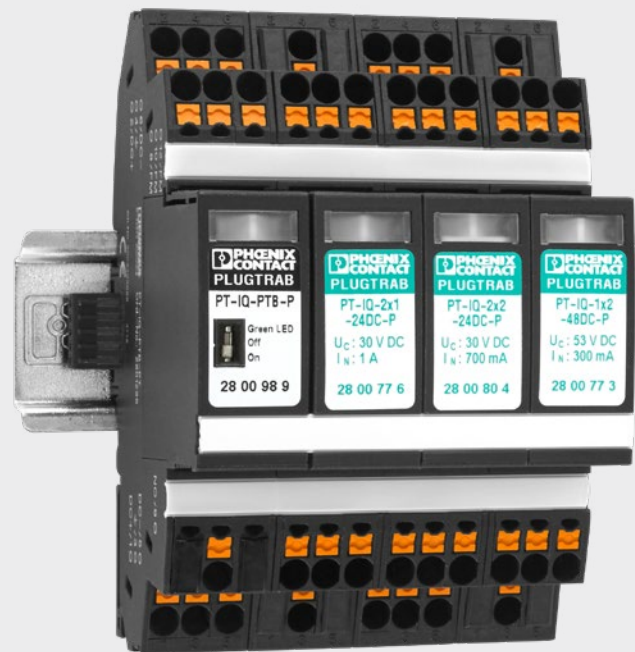

### Intelligent and predictive

PLUGTRAB PT-IQ – surge protection with intelligent monitoring of applications in the extra-low-voltage range with three-stage function indicator.

➤ More information starting on page 62

	TERMITRAB complete	PLUGTRAB PT-IQ	CLIXTRAB	SURGETRAB
Mounting type	DIN rail	DIN rail	DIN rail	Can be screwed onto field device
Overall width	3.5 mm / 6.2 mm	17.5 mm	10.3 mm	½ inch, M20
Connection technology	Push-in / screw	Push-in / screw	Push-in	Cables
Pluggable / not pluggable	Yes / Yes	Yes / No	Yes / No	-
Status indicator	2-stage, mechanical	3-stage, LED	2-stage, mechanical	No
Remote signaling	Optional	Yes	Optional	No
Can be tested with CHECKMASTER 2	Yes	Not necessary	Yes	No
Intrinsically safe versions (Ex i)	Yes	Yes	No	Yes



### Space-saving for high signal voltages

CLIXTRAB – the combination of surge protection and terminal block for signal voltages up to 230 V AC/DC with function indicator.

➤ More information starting on page 68



### Robust for applications in the field

SURGETRAB – surge protection for easy mounting on field devices.

➤ More information starting on page 72

## Typical applications for MCR products

### Process technology

Transient overvoltages are often indirectly coupled into copper cables, for example, as when lightning strikes in the vicinity. These cause defects in electronic MCR systems in process technology systems, which can lead to system downtime and costly repair work. Surge protection designed specifically to protect your system against surge voltages is always recommended. This ensures that your system is in stable condition over the long term. The comprehensive portfolio includes an optimized circuit for every application. The surge protective devices feature a variety of additional functions

that make maintenance easier in large processing systems. Products with an integrated disconnect knife enable separation between the controller and the field cable, for example. This allows maintenance work and measurements to be carried out easily. Product families for potentially explosive areas and for direct installation on measuring heads complete the portfolio.



*Stable processes even in extreme weather situations*

### Wind turbine generators

Maximum system availability, safe operation, and efficient maintenance are required to optimize the energy yield from wind turbine generators. Surge protection for MCR technology helps you in reaching these goals. Wind turbine generators are installed in exposed locations. They are often the tallest structures in the area, so they are hit by many lightning strikes. A broad portfolio of surge protective devices makes it possible to protect the high number of sensors in a wind turbine generator. System availability is optimized. This provides optimum protection of systems for blade load monitoring,

wind measurement, speed measurement, and condition monitoring of the system. State monitoring with a remote signaling option for surge protective devices is available to ensure efficient maintenance. Even the harsh ambient conditions in which a wind turbine generator operates cannot impede optimal protection.



*Protected signal circuits at lofty heights*

### Water and wastewater treatment

High system availability and a comprehensive maintenance concept are essential for state-of-the-art system operation in water and wastewater treatment. To ensure this, the use of surge protection for MCR technology is recommended. The various devices offer numerous additional functions, such as the ability to permanently monitor the status of the surge protection via telecommunication systems in a central control room. This reduces the amount of maintenance required for external structures such as groundwater wells and wastewater pumping stations.

Products with integrated knife disconnection also simplify the maintenance and diagnostics of connected field devices. The devices can even be used reliably in harsh ambient conditions. The product portfolio for surge protection in the field of MCR technology includes solutions for protecting various interfaces in the water and wastewater treatment industry.



*Clean water with high system availability*

## Photovoltaics

Data networking is playing an ever increasing role in photovoltaic systems. Due to the decentral structure in ground-mounted systems, transmission systems are particularly exposed to the dangers of coupled, transient overvoltages. Sensors, data loggers, and transmission systems ensure the comprehensive, split-second recording of PV performance data and meteorological measured values. Permanent availability is prerequisite for the stable operation of such a system. It is necessary to use special surge protection products to protect the copper-based transmission systems against transient

surge voltages during storms. In the worst case, a transient overvoltage can cause a complete failure of the system monitoring system if control and data cables are unprotected. Depending on requirements, our comprehensive portfolio includes the perfect surge protective devices to protect measurement, control, and data cables in photovoltaic projects.



*Prevention of complete PV facility failures*

## Railway infrastructure

Control command and signaling technology ensures safe and reliable railway operations. In signal boxes, secured routes are set up, points are set, and the corresponding signals are switched. In addition to signals, external signal technology systems also contain components such as axle counters and track-clear signaling devices, which are necessary for interference-free operation. Overvoltages that are caused by lightning strikes or sparkovers on overhead lines, for example, can occur at any time in the extensive rail network and endanger the measurement and control data.

Reliable lightning and surge protection is therefore essential to protect signal technology and control systems from damage caused by transient couplings. Since high signal voltages are often used in railway technology, the CLIXTRAB product family of surge protective devices offers optimal protection even for these special requirements.



*Modern railway infrastructure with surge protection*

## Transportation infrastructure

Transient overvoltages caused by lightning strikes or switching operations can damage technical systems and devices, and even cause them to fail. Despite their underground location, tunnels are not protected against such events. There are numerous safety-relevant systems in a tunnel, such as ventilation, emergency lighting, and traffic signal control, and it is essential to ensure that they operate reliably. Any failures that arise due to overvoltage will lead to expensive repairs and even tunnel closure. Each interface therefore requires suitable surge protection.

The extensive product range features the right solution for every requirement, such as for fast data communication or for monitoring and controlling technical systems. Intelligent components detect when their performance limit has been reached at an early stage so that the protective device can be replaced and tunnel operation remains interference-free.



*Safely through the tunnel thanks to surge protection*

Surge protection for measurement and control technology

## Narrow protection for MCR applications

Slim design, powerful performance

TERMITRAB complete is the world's narrowest surge protection solution for MCR technology. Starting from an overall width of just 3.5 mm, the product family provides you with a complete system with many advantages. Depending on your requirements, choose from simple protective devices in a slim design to items with comprehensive functions.

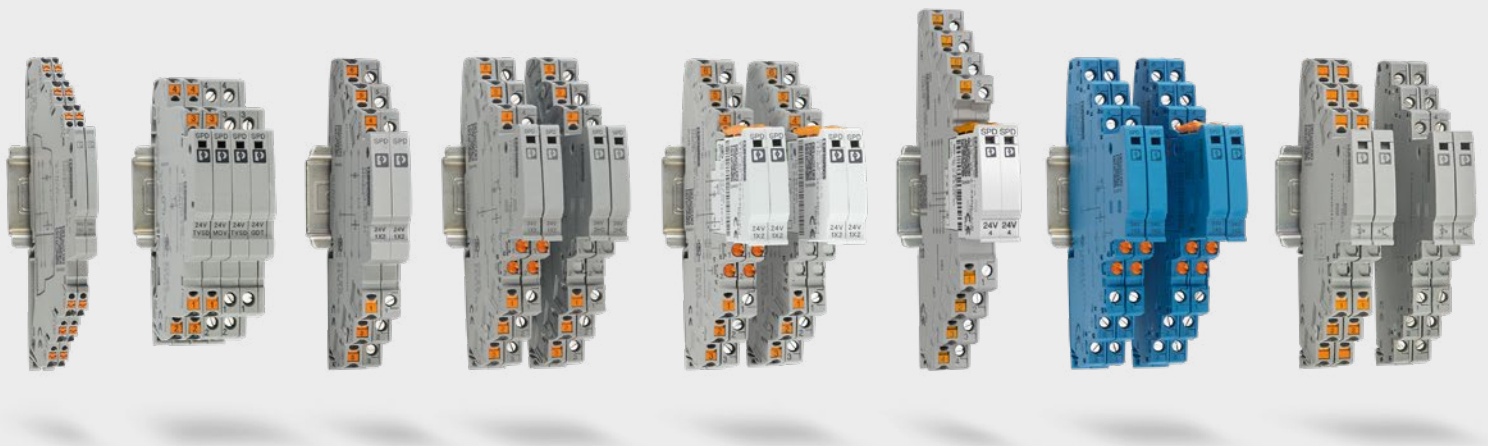

### Your advantages

- ✓ Space saving, thanks to the world's narrowest surge protection starting from 3.5 mm
- ✓ Stay informed at all times with the integrated status indicator and remote signaling option
- ✓ Ideal protection for your application with the tailored portfolio

# TERMITRAB complete – compact for every application

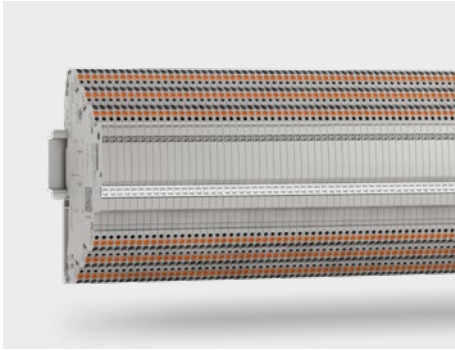

## Extremely narrow overall width

Starting at an overall width of just 3.5 mm – protect up to 572 signals across 1 m with the ultra-slim overall width.



## Status indicator and remote signaling

Always know what is going on. With a mechanical status indicator on the protective device or via optional remote signaling modules in the control room.

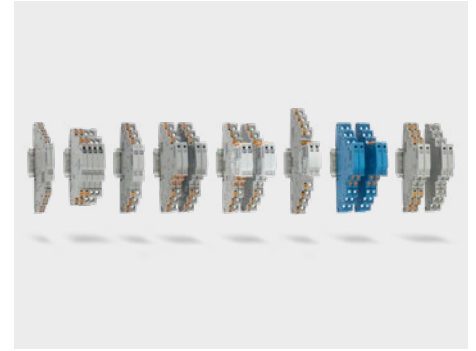

## Tailored portfolio

With TERMITRAB complete, you will find the ideal surge protective device for your specific requirements.

## Testing and maintenance made easy

TERMITRAB complete features versions with integrated knife disconnection. This saves even more installation space. The disconnection option can be used on the top two terminal levels. For example, insulation measurements can be carried out on the cables without the voltage-limiting components distorting the test results.

Pluggable surge protective devices can be replaced during maintenance without having to access the wiring. The measuring signal is not interrupted, which means that errors are not generated in the measurement results.

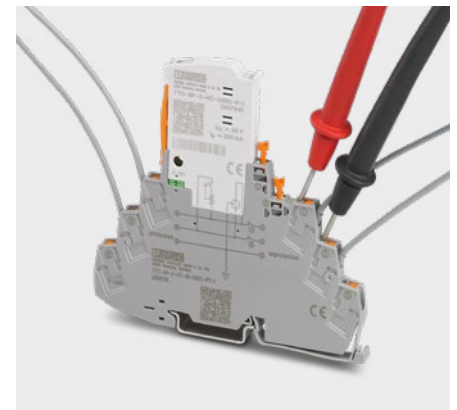



Testing directly at the protective device

## Item designation key



TTC-6P-1X2-F-M-24DC-PT-I	Example	Further options
Indicator (status indicator)	Without indicator (status indicator)	
Connection	Push-in	Universal terminal (screw)
Nominal voltage	24 V DC	5 V DC / 12 V DC / 48 V DC / 60 V DC / 120 V AC
Properties	Knife disconnection	Ex applications
Grounding	Floating	Directly grounded
Protective circuit	1X2 ONEPAIR (isolated)	2X1 / 2 / 2-HC / 3 / 3-HF / 4 / TELE / APL
Pluggable	Pluggable	One-piece
Housing width	6 mm	3.5 mm
Product family	TERMITRAB complete	

# TERMITRAB complete – compact for every application

## Basic protection for isolated signal circuits and signals with a common reference potential

				
	<b>Pluggable</b>		<b>No</b>	
<b>Knife disconnection</b>		<b>No</b>		
Number of signal wires		3		
Rated current		250 mA (70°C)		
Maximum continuous voltage $U_c$		30 V DC / 21 V AC		
IEC test classification		C1, C2, C3, D1		
Pulse discharge current $I_{imp}$ (10/350) $\mu$ s		0.5 kA		
Total discharge current $I_{total}$ (8/20) $\mu$ s		10 kA		
Resistance per path		2.2 $\Omega$ $\pm$ 10%		
Push-in connection		TTC-3-2X1-24DC-PT 2907326		
		TTC-3-1X2-24DC-PT 2907325		

## Isolated signal circuits

				
	<b>Pluggable</b>		<b>Yes</b>	
<b>Knife disconnection</b>		<b>Yes</b>		
Number of signal wires		3		
Rated current		600 mA (56°C)		
Maximum continuous voltage $U_c$		30 V DC / 21 V AC		
IEC test classification		C1, C2, C3, D1		
Pulse discharge current $I_{imp}$ (10/350) $\mu$ s		0.5 kA		
Total discharge current $I_{total}$ (8/20) $\mu$ s		10 kA		
Resistance per path		1.65 $\Omega$ $\pm$ 20%		
Push-in connection		TTC-6P-3-HF-F-M-24DC-PT-I 2906797		
		TTC-6-3-HF-F-M-24DC-PT-I 2906779		
Screw connection		TTC-6P-3-HF-F-M-24DC-UT-I 2906787		
		TTC-6-3-HF-F-M-24DC-UT-I 2906770		

# TERMITRAB complete – compact for every application

## The right product is just two clicks away

TERMITRAB complete offers over 100 items with different circuit and voltage variants. Various connection technologies and product features complete the portfolio. This variety provides a solution for virtually all applications in MCR technology. The configurator helps you to keep track of everything. In just two clicks, you can navigate to a selection of products that offer optimum protection for your application. First, select the application or interface that you want to protect. Then select the desired design. You then also have the option to define additional features on the selection page.

If a suitable TERMITRAB complete product is not available for your application, use the advanced search to find more items.

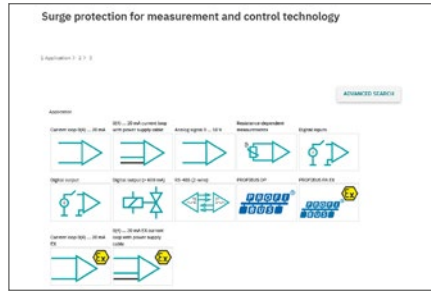

Step 1:  
Select the application or interface

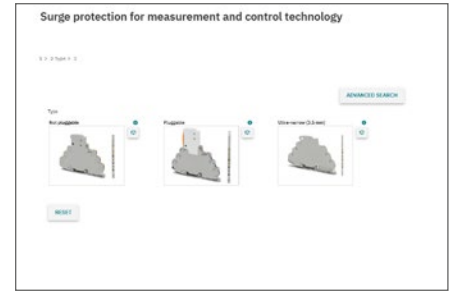

Step 2:  
Select the design

For further information on the online configurator, simply enter the web code in the search field on our website.

 **Web code: #1389**

## Direct and indirect grounding

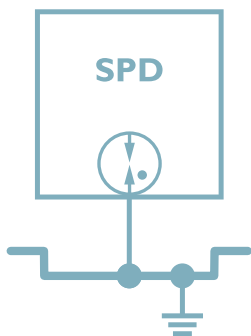

### Indirect grounding

For surge protective devices with “F” in the name, the connection terminal blocks for the shield or the reference potential are indirectly connected to the metal mounting foot via a gas discharge tube and thus to the DIN rail.

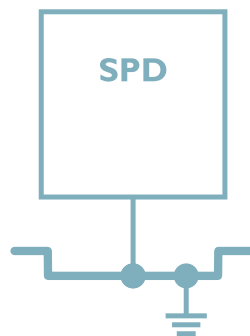





### Direct grounding



For surge protective devices without “F” in the name, the connection terminal blocks for the shield or the reference potential are directly connected to the DIN rail via the metal mounting foot.

# TERMITRAB complete – compact for every application

## Common reference potential, directly grounded

				
<b>Pluggable</b>	<b>Yes</b>	<b>Yes</b>	<b>No</b>	<b>No</b>
<b>Knife disconnection</b>	<b>Yes</b>	<b>No</b>	<b>Yes</b>	<b>No</b>
Number of signal wires	3	3	3	3
Rated current	600 mA (56°C)		600 mA (40°C)	
Maximum continuous voltage $U_c$	30 V DC / 21 V AC			
IEC test classification	C1, C2, C3, D1			
Pulse discharge current $I_{imp}$ (10/350) $\mu$ s	0.5 kA			
Total discharge current $I_{total}$ (8/20) $\mu$ s	10 kA			
Resistance per path	1.65 $\Omega$ $\pm$ 20%			
Push-in connection	TTC-6P-2X1-M-24DC-PT-I <a href="#">2906753</a>	TTC-6P-2X1-24DC-PT-I <a href="#">2906816</a>	TTC-6-2X1-M-24DC-PT-I <a href="#">2906729</a>	TTC-6-2X1-24DC-PT <a href="#">2906805</a>
Screw connection	TTC-6P-2X1-M-24DC-UT-I <a href="#">2906741</a>	TTC-6P-2X1-24DC-UT-I <a href="#">2906810</a>	TTC-6-2X1-M-24DC-UT-I <a href="#">2906716</a>	TTC-6-2X1-24DC-UT <a href="#">2906799</a>





## Common reference potential, indirectly grounded

		
<b>Pluggable</b>	<b>Yes</b>	<b>No</b>
<b>Knife disconnection</b>	<b>Yes</b>	<b>Yes</b>
Number of signal wires	3	3
Rated current	600 mA (56°C)	600 mA (40°C)
Maximum continuous voltage $U_c$	30 V DC / 21 V AC	
IEC test classification	C1, C2, C3, D1	
Pulse discharge current $I_{imp}$ (10/350) $\mu$ s	0.5 kA	
Total discharge current $I_{total}$ (8/20) $\mu$ s	10 kA	
Resistance per path	1.65 $\Omega$ $\pm$ 20%	
Push-in connection	TTC-6P-3-HF-F-M-24DC-PT-I <a href="#">2906797</a>	TTC-6-3-HF-F-M-24DC-PT-I <a href="#">2906779</a>
Screw connection	TTC-6P-3-HF-F-M-24DC-UT-I <a href="#">2906787</a>	TTC-6-3-HF-F-M-24DC-UT-I <a href="#">2906770</a>



# TERMITRAB complete – compact for every application



1  
2  
3  
4  
5

Surge protection for measurement and control technology

For resistance-dependent measurements				
				
<b>Pluggable</b>	<b>Yes</b>	<b>Yes</b>	<b>Yes</b>	<b>No</b>
<b>Knife disconnection</b>	<b>No</b>	<b>No</b>	<b>No</b>	<b>No</b>
Number of signal wires	4	3	3	2
Rated current	2.5 A (60°C, for insulated systems)	5 A (55°C)		450 mA (80°C)
Maximum continuous voltage U <sub>c</sub>	36 V DC / 30 V AC	5 V DC / 3 V AC	30 V DC / 21 V AC	
IEC test classification	C1, C2, C3, D1	C1, C2, C3	C1, C2, C3, D1	
Pulse discharge current I <sub>imp</sub> (10/350) μs	0.5 kA	—	0.5 kA	
Total discharge current I <sub>total</sub> (8/20) μs	10 kA			
Resistance per path	0.03 Ω	<0.1 Ω		≤100 mΩ
Push-in connection	TTC-6P-4-24DC-PT-I <a href="#">1106014</a>	TTC-6P-3-5DC-PT-I <a href="#">1061385</a>	TTC-6P-3-24DC-PT-I <a href="#">1061383</a>	TTC-6-2-24DC-PT <a href="#">2906806</a>
Screw connection	TTC-6P-4-24DC-UT-I <a href="#">1106013</a>			TTC-6-2-24DC-UT <a href="#">2906800</a>

# TERMITRAB complete – compact for every application





For potentially explosive applications with isolated signal circuits		
		
<b>Pluggable</b>	<b>Yes</b>	<b>No</b>
<b>Knife disconnection</b>	<b>Yes</b>	<b>Yes</b>
Number of signal wires	3	3
Rated current	600 mA (40°C)	
Maximum continuous voltage $U_c$	30 V DC	
IEC test classification	C1, C2, C3, D1	
Pulse discharge current $I_{imp}$ (10/350) $\mu$ s	0.5 kA	
Total discharge current $I_{total}$ (8/20) $\mu$ s	10 kA	
Resistance per path	1.65 $\Omega$ $\pm$ 20%	
Screw connection	TTC-6P-3-HF-F-M-EX-24DC-UT-I 2906828	TTC-6-3-HF-F-M-EX-24DC-UT-I 2906823





For potentially explosive applications with resistance-dependent measurements	
	
<b>Pluggable</b>	<b>Yes</b>
<b>Knife disconnection</b>	<b>No</b>
Number of signal wires	3
Rated current	5 A (55°C)
Maximum continuous voltage $U_c$	30 V DC
IEC test classification	C1, C2, C3, D1
Pulse discharge current $I_{imp}$ (10/350) $\mu$ s	0.5 kA
Total discharge current $I_{total}$ (8/20) $\mu$ s	10 kA
Resistance per path	<0.1 $\Omega$
Screw connection	TTC-6P-3-EX-24DC-UT-I 1064665

# TERMITRAB complete – compact for every application

1  
2  
3  
4  
5





Surge protection for measurement and control technology

Signal circuits with high rated current				
				
<b>Pluggable</b>	<b>Yes</b>	<b>Yes</b>	<b>No</b>	<b>No</b>
<b>Knife disconnection</b>	<b>Yes</b>	<b>No</b>	<b>Yes</b>	<b>No</b>
Number of signal wires	2	2	2	2
Rated current	6 A (55°C)			
Maximum continuous voltage U <sub>c</sub>	30 V DC / 21 V AC			
IEC test classification	C1, C2, C3, D1			
Pulse discharge current I <sub>imp</sub> (10/350) μs	0.5 kA			
Total discharge current I <sub>total</sub> (8/20) μs	5 kA			
Resistance per path	≤100 mΩ			
Push-in connection	TTC-6P-2-HC-M-24DC-PT-I <a href="#">2906755</a>	TTC-6P-2-HC-24DC-PT-I <a href="#">2906817</a>	TTC-6-2-HC-M-24DC-PT-I <a href="#">2906731</a>	TTC-6-2-HC-24DC-PT-I <a href="#">2908439</a>
Screw connection	TTC-6P-2-HC-M-24DC-UT-I <a href="#">2906743</a>	TTC-6P-2-HC-24DC-UT-I <a href="#">2906811</a>	TTC-6-2-HC-M-24DC-UT-I <a href="#">2906719</a>	TTC-6-2-HC-24DC-UT-I <a href="#">2908438</a>



Single-level protective devices, fine protection with suppressor diode				
				
<b>Pluggable</b>	<b>No</b>	<b>No</b>	<b>No</b>	<b>No</b>
<b>Knife disconnection</b>	<b>No</b>	<b>No</b>	<b>No</b>	<b>No</b>
Number of signal wires	2	1	2	2
Rated current	10 A (60°C)		6 A (55°C)	
Maximum continuous voltage U <sub>c</sub>	30 V DC / 21 V AC			15 V DC / 10 V AC
IEC test classification	C3		C1, C3	C1, C2, C3
Total discharge current I <sub>total</sub> (8/20) μs	—		1 kA	2 kA
Resistance per path	≤100 mΩ			
Direction of action	Line-line			
Push-in connection	TTC-6-TVSD-D-24DC-PT-I <a href="#">2906851</a>	TTC-6-TVSD-C-24DC-PT-I <a href="#">2906848</a>	TTC-6-2XTVSD-24DC-PT <a href="#">2906808</a>	TTC-6-2XTVSD-12DC-PT <a href="#">2906807</a>
Screw connection	TTC-6-TVSD-D-24DC-UT-I <a href="#">2906834</a>	TTC-6-TVSD-C-24DC-UT-I <a href="#">2906831</a>		

# TERMITRAB complete – compact for every application

## Single-level protective devices, medium protection with metal oxide varistor

				
<b>Pluggable</b>	<b>No</b>	<b>No</b>	<b>No</b>	<b>No</b>
<b>Knife disconnection</b>	<b>No</b>	<b>No</b>	<b>No</b>	<b>No</b>
Number of signal wires	2	2	1	1
Rated current	10 A (60°C)			
Maximum continuous voltage $U_c$	30 V DC / 21 V AC	150 V DC / 150 V AC	30 V DC / 21 V AC	150 V DC / 150 V AC
IEC test classification	C1, C2, C3			
Resistance per path	$\leq 100$ m $\Omega$			
Direction of action	Line-line		Line-earth ground	
Push-in connection	TTC-6-MOV-D-24DC-PT-I <a href="#">2906859</a>		TTC-6-MOV-C-24DC-PT-I <a href="#">2906854</a>	TTC-6-MOV-C-120AC-PT-I <a href="#">2906858</a>
Screw connection	TTC-6-MOV-D-24DC-UT-I <a href="#">2906841</a>	TTC-6-MOV-D-120AC-UT-I <a href="#">1109673</a>	TTC-6-MOV-C-24DC-UT-I <a href="#">2906837</a>	TTC-6-MOV-C-120AC-UT-I <a href="#">2906840</a>



## Single-level protective devices, coarse protection with gas discharge tube

	
<b>Pluggable</b>	<b>No</b>
<b>Knife disconnection</b>	<b>No</b>
Number of signal wires	1
Rated current	1 A DC (60 °C) / 2 A AC (60 °C)
Maximum continuous voltage $U_c$	28 V DC / 36 V AC
IEC test classification	C1, C2, C3, D1
Pulse discharge current $I_{imp}$ (10/350) $\mu$ s	0.5 kA
Resistance per path	$\leq 100$ m $\Omega$
Direction of action	Line-earth ground
Push-in connection	TTC-6-GDT-C-24AC-PT-I <a href="#">2906860</a>
Screw connection	TTC-6-GDT-C-24AC-UT-I <a href="#">2906842</a>

# TERMITRAB complete – compact for every application

- 1
- 2
- 3
- 4
- 5

Surge protection for measurement and control technology

Remote signaling sets and modules		
		
Description	Remote signaling module – transmitter	Remote signaling module – receiver
Push-in connection	TTC-6-FMTX-PT <a href="#">1193565</a>	TTC-6-FMRX-PT <a href="#">1193571</a>
Screw connection	TTC-6-FMTX-UT <a href="#">1193555</a>	TTC-6-FMRX-UT <a href="#">1193557</a>

## Intelligent and predictive

### Systematic surge protection

PLUGTRAB PT-IQ is a system comprising a supply and remote signaling module and the actual surge protective devices with a three-level status indicator. One module supplies the protective devices and provides the group remote signaling for up to 28 protective modules. Each voltage-limiting component is intelligently monitored.



### Your advantages

- ✓ Preventive replacement of surge protective devices with pre-existing damage with multi-stage display and remote signaling
- ✓ Direct installation in Ex zone 2 with protective devices for intrinsically safe circuits up to Ex zone 0
- ✓ Rapid and error-free installation with DIN rail connectors and coded plugs

# PLUGTRAB PT-IQ – intelligent and predictive



## Visual control function

The status at a glance: green = everything ok, yellow = replacement recommended, red = replacement required.

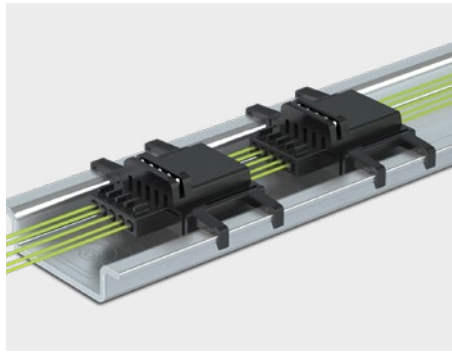

## Permanent installation

Power supply and status information via individual DIN rail connectors that can be extended to form a bus.



## Easy to extend

A controller supplies up to 28 protective modules and collects the status of the protective devices.

## Always know what is going on

The protective devices of the PLUGTRAB range feature practical functions. The protective devices are pluggable, which means they can be quickly replaced when necessary, even when the system is in operation.

PLUGTRAB PT-IQ provides multi-stage monitoring of the protective devices and group messages via the controller. A yellow status signal indicates that the performance limit has been reached, as a result of frequent surge voltages. The protective devices are still functional. Your system continues to be protected. However, to avoid unnecessary

service operations, a replacement is recommended. Remote signaling enables you to check how well your system is being protected at any time and place.



PLUGTRAB PT-IQ with three-level status indicator

### Item designation key

PT-IQ-1X2+F- 24DC-PT	Example	Further options
PT-IQ-1X2+F- 24DC-PT	Push-in	Universal terminal (screw)
	24 V DC	5 V DC / 12 V DC / 48 V DC / 60 V DC
	Floating (indirectly grounded)	Directly grounded
	1X2 ONEPAIR (isolated)	2X1 / 3-HF / 4X1 / 5-HF / TELE / PTB
	PLUGTRAB-IQ	

# PLUGTRAB PT-IQ – intelligent and predictive

## Isolated signal circuits, directly grounded

		
<b>Pluggable</b>	<b>Yes</b>	<b>Yes</b>
Number of signal wires	2	4
Rated current	1000 mA (40°C)	700 mA (50°C)
Maximum continuous voltage $U_c$	30 V DC / 21 V AC	
IEC test classification	C1, C2, C3, D1	
Pulse discharge current $I_{imp}$ (10/350) $\mu$ s	2.5 kA	
Total discharge current $I_{total}$ (8/20) $\mu$ s	20 kA	
Cut-off frequency	Type 1.1 MHz	
Resistance per path	1.2 $\Omega$ $\pm$ 5%	
Direction of action	Line-line Line-signal ground/shield Optional signal ground/shield-earth ground	
Push-in connection	PT-IQ-1X2-24DC-PT <a href="#">2801255</a>	PT-IQ-2X2-24DC-PT <a href="#">2801263</a>
Screw connection	PT-IQ-1X2-24DC-UT <a href="#">2800976</a>	PT-IQ-2X2-24DC-UT <a href="#">2800980</a>

## Isolated signal circuits, indirectly grounded

		
<b>Pluggable</b>	<b>Yes</b>	<b>Yes</b>
Number of signal wires	2	4
Rated current	1000 mA (40°C)	700 mA (50°C)
Maximum continuous voltage $U_c$	30 V DC / 21 V AC	
IEC test classification	C1, C2, C3, D1	
Pulse discharge current $I_{imp}$ (10/350) $\mu$ s	2.5 kA	
Total discharge current $I_{total}$ (8/20) $\mu$ s	20 kA	
Cut-off frequency	Type 1.1 MHz	
Resistance per path	1.2 $\Omega$ $\pm$ 5%	
Direction of action	Line-line Line-signal ground/shield Optional signal ground/shield-earth ground	
Push-in connection	PT-IQ-1X2+F-24DC-PT <a href="#">2801256</a>	PT-IQ-2X2+F-24DC-PT <a href="#">2801264</a>
Screw connection	PT-IQ-1X2+F-24DC-UT <a href="#">2800977</a>	PT-IQ-2X2+F-24DC-UT <a href="#">2800981</a>

# PLUGTRAB PT-IQ – intelligent and predictive



1  
2  
3  
4  
5



Surge protection for measurement and control technology

Common reference potential, directly grounded		
		
<b>Pluggable</b>	<b>Yes</b>	<b>Yes</b>
Number of signal wires	3	5
Rated current	1000 mA (40°C)	700 mA (50°C)
Maximum continuous voltage $U_c$	30 V DC / 21 V AC	
IEC test classification	C1, C2, C3, D1	
Pulse discharge current $I_{imp}$ (10/350) $\mu$ s	2.5 kA	
Total discharge current $I_{total}$ (8/20) $\mu$ s	20 kA	
Resistance per path	1.2 $\Omega$ $\pm$ 5%	
Direction of action	Line-line Line-signal ground/shield Optional signal ground/shield-earth ground	
Push-in connection	PT-IQ-2X1-24DC-PT <a href="#">2801247</a>	PT-IQ-4X1-24DC-PT <a href="#">2801271</a>
Screw connection	PT-IQ-2X1-24DC-UT <a href="#">2800787</a>	PT-IQ-4X1-24DC-UT <a href="#">2800982</a>

Common reference potential, indirectly grounded		
		
<b>Pluggable</b>	<b>Yes</b>	<b>Yes</b>
Number of signal wires	3	5
Rated current	1000 mA (40°C)	700 mA (50°C)
Maximum continuous voltage $U_c$	30 V DC / 21 V AC	
IEC test classification	C1, C2, C3, D1	
Pulse discharge current $I_{imp}$ (10/350) $\mu$ s	2.5 kA	
Total discharge current $I_{total}$ (8/20) $\mu$ s	20 kA	
Resistance per path	1.2 $\Omega$ $\pm$ 5%	
Direction of action	Line-line Line-signal ground/shield Optional signal ground/shield-earth ground	
Push-in connection	PT-IQ-2X1+F-24DC-PT <a href="#">2801248</a>	PT-IQ-4X1+F-24DC-PT <a href="#">2801272</a>
Screw connection	PT-IQ-2X1+F-24DC-UT <a href="#">2800788</a>	PT-IQ-4X1+F-24DC-UT <a href="#">2800983</a>

# PLUGTRAB PT-IQ – intelligent and predictive

For potentially explosive applications		
		
<b>Pluggable</b>	<b>Yes</b>	<b>Yes</b>
<b>Knife disconnection</b>	<b>No</b>	<b>No</b>
Number of signal wires	2	4
Rated current	350 mA	
Maximum continuous voltage $U_c$	30 V DC / 21 V AC	
IEC test classification	C1, C2, C3, D1	
Pulse discharge current $I_{imp}$ (10/350) $\mu$ s	2 kA	
Total discharge current $I_{total}$ (8/20) $\mu$ s	20 kA	
Cut-off frequency	Type 1.1 MHz	
Resistance per path	1.2 $\Omega$ $\pm$ 5%	
Direction of action	Line-line Line-signal ground/shield Optional signal ground/shield-earth ground	
Screw connection	PT-IQ-1X2-EX-24DC-UT <a href="#">2801512</a>	PT-IQ-2X2-EX-24DC-UT <a href="#">2801513</a>

Supply and remote signaling modules		
		
<b>Connection technology</b>	<b>Screw connection</b>	<b>Push-in connection</b>
Type	PT-IQ-PTB-UT	PT-IQ-PTB-PT
Item no.	<a href="#">2800768</a>	<a href="#">2801296</a>

# PLUGTRAB PT-IQ – intelligent and predictive

- 1
- 2
- 3
- 4
- 5

Surge protection for measurement and control technology

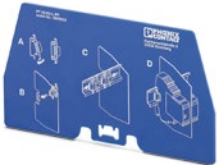
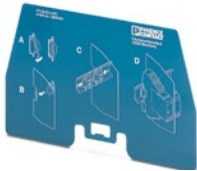
Accessories: partition plates		
		
Product type	Partition plate	
Description	Partition plate for NS 35/7,5 DIN rails	Partition plate for NS 35/7,5 isolated DIN rails (DIN rail is isolated via the "AB/NS" support bracket)
Type	PT-IQ-EX-L-PP	PT-IQ-EX-H-PP
Item no.	2905023	2905024

Surge protection for measurement and control technology

## Surge protection and terminal blocks

### Space-saving for high signal voltages

The combination of terminal block and surge protection plug provides safe and space-saving protection for your system. Comprehensive diagnostic and remote signaling options enable easy maintenance. The powerful protective circuit featuring integrated overload protection provides superior system availability.



### Your advantages

- ✓ Easy installation with Push-in terminal blocks with pluggable surge protection
- ✓ High system availability thanks to a high-performance protective circuit with integrated overload protection
- ✓ Quick and easy diagnostics with optional remote signaling for integration into digital infrastructures

# CLIXTRAB – space-saving for high signal voltages

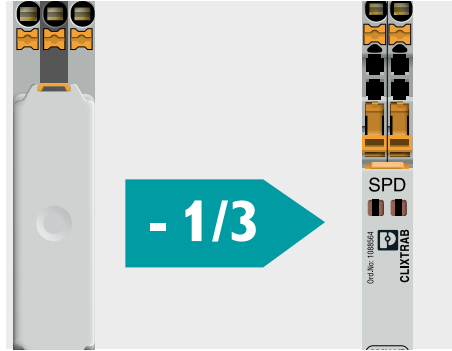
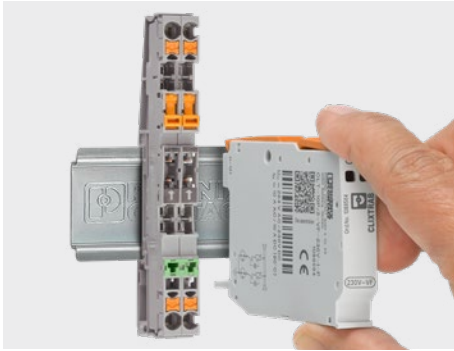

## Easy handling

Easy installation with the combination of Push-in terminal blocks and pluggable surge protection.

## Narrow overall width

Three become two. Use just two terminal blocks to protect two signal paths in an overall width of 10.3 mm.

## Fast error identification

Rapid diagnostics with mechanical status indicator and optional remote signaling for integration into digital infrastructures.

## Overload protection and remote signaling

CLIXTRAB features a mechanical disconnect device as overload protection. In the event of overload, the device ensures that faulty components are disconnected from the mode of protection – without auxiliary energy. It is easy to identify faulty protective plugs, as the overload protection is connected to the visual status indicator.

Visual remote signaling is also possible in addition to indication on the plug. The optional remote signaling modules simplify error diagnostics since regular on-site testing is not possible for all components, especially in distributed

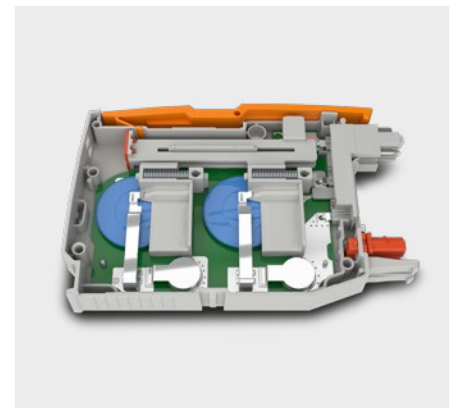

structures. Here, the status of the surge protective devices is transferred to subsequent systems via a floating contact. Monitoring is easily incorporated in the control center technology and this transfers the status to the control room. Targeted maintenance can be performed easily and efficiently.









*Mechanical disconnect device for permanent availability*

Item designation key		
CLT-10P/2-VF-230V-I-P	Example	Further options
Design	Connectors	-
Indicator	With indicator (status indicator)	-
Nominal voltage	230 V	12 V DC / 24 V DC / 60 V DC
Protective circuit	VF	2 / MOV
Signal circuits	2-wire	4-wire
Housing width	10 mm, pluggable	20 mm, pluggable
Product family	CLIXTRAB	

# CLIXTRAB – space-saving for high signal voltages

Protective plugs			
			
<b>Nominal voltage</b>	<b>12 V DC</b>	<b>24 V DC</b>	<b>60 V DC</b>
Type in accordance with IEC	C1, C2, C3, D1		
Maximum continuous voltage $U_c$	15 V DC / 10 V AC	30 V DC / 21 V AC	75 V DC / 53 V AC
Rated current	600 mA (80°C) / 200 mA (80°C)		
Total discharge current $I_{total}$ (8/20) $\mu$ s	10 kA		
Number of disconnect terminal blocks needed	2		
Type	CLT-10P/2-2-12V-I-P	CLT-10P/2-2-24V-I-P	CLT-10P/2-2-60V-I-P
Item no.	1088569	1088570	1088573

Protective plugs for high nominal voltage			
			
<b>Nominal voltage</b>	<b>240 V AC</b>		<b>240 V AC</b> <span style="background-color: #e91e63; color: white; padding: 2px;">NEW</span>
Type in accordance with IEC	C1, C2, C3, D1		
Maximum continuous operating voltage $U_c$	230 V DC / 264 V AC		250 V DC / 275 V AC
Rated current	10 A AC (80°C / 10 A AC C) / 6 A DC (80°C / 6.3 A DC F) / 10 A DC (80°C / 10 A DC D01 gR)		
Total discharge current $I_{total}$ (8/20) $\mu$ s	6 kA	12 kA	6 kA
Number of disconnect terminal blocks needed	2	4	2
Type	CLT-10P/2-VF-230V-I-P	CLT-20P/4-VF-230V-I-P	CLT-10P/2-MOV-230V-I-P
Item no.	1088564	1088567	1669983

Accessories – remote signaling modules		
		
<b>Description</b>	<b>Remote signaling module – transmitter</b>	<b>Remote signaling module – receiver</b>
Push-in connection	TTC-6-FMTX-PT 1193565	TTC-6-FMRX-PT 1193571
Screw connection	TTC-6-FMTX-UT 1193555	TTC-6-FMRX-UT 1193557

# CLIXTRAB – space-saving for high signal voltages





1  
2  
3  
4  
5

Surge protection for measurement and control technology

## Base element for protective plugs

			
<b>Description</b>	<b>Disconnect terminal block</b>	<b>Disconnect terminal block</b>	<b>Disconnect terminal block</b>
Nominal current I <sub>N</sub>	20 A	20 A	20 A
Nominal voltage U <sub>N</sub>	400 V	400 V	400 V
Cross-section range	0.14 mm <sup>2</sup> ... 4 mm <sup>2</sup> / 26 ... 12	0.14 mm <sup>2</sup> ... 4 mm <sup>2</sup> / 26 ... 12	0.14 mm <sup>2</sup> ... 4 mm <sup>2</sup> / 26 ... 12
DIN rail type	NS 35/7.5 / NS 35/15	NS 35/7.5 / NS 35/15	NS 35/7.5 / NS 35/15
Connection technology	Push-in connection	Push-in connection	Push-in connection
Number of positions	1-pos.	1-pos.	1-position
Type	PT 2,5-MT-CLT	PT 2,5-QUATTRO-MT-CLT	PT 2,5-TWIN-MT-CLT
Item no.	1087698	1251103	1251104

## Accessories for base element

			
<b>Description</b>	<b>End cover</b>	<b>End cover</b>	<b>End cover</b>
Type	D-PT 2,5-MT-CLT	D-PT 2,5-QUATTRO-MT-CLT	D-PT 2,5-TWIN-MT-CLT
Item no.	1088502	1251101	1251102

## Simplify maintenance work

CLIXTRAB includes several features that will make maintenance work much easier. The terminal block's integrated knife disconnection can be used to disconnect the signal circuit without accessing the signal lines. This function is not just useful for maintenance work or troubleshooting, but also during startup. When the knife disconnection is opened, it is very easy to perform a measurement of the operating current or the insulation. Testing the lightning and surge protective devices at regular intervals is not only recommended, but indeed prescribed in many areas of application. Due to the surge protection

plug, which can be removed and inserted without causing any interruption, the signal lines in the terminal block remain untouched. System availability is maintained while the plug is being tested or replaced.

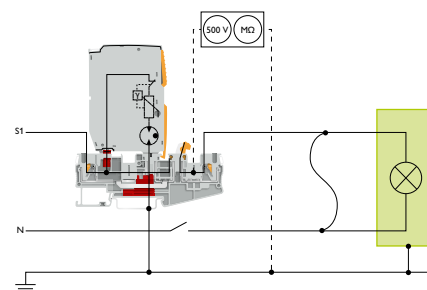

Simple dielectric test

## Robust surge protection

### Fuse protection directly on the measuring head

Screw in, connect, done – SURGETRAB protective devices are designed for all common standard signals that are attached directly to the measuring head via their connecting threads. This mounting type saves time and money, and there is no need for an additional connection box for installing the surge protection.



### Your advantages

- ✓ Easy field mounting with standardized thread
- ✓ Versatile in use with universal protective circuit
- ✓ Use under extreme ambient conditions thanks to robust design

# SURGETRAB – robust for applications in the field



## Installation

Screw in, connect, done – the products feature a connection thread for direct installation on the measuring head.



## Shield fast connection

The conductor shield can be secured reliably in the shield clamp using a cable tie.



## Connection versions

The product family features versions for through-wiring as well as for parallel wiring.

## For universal use

This SURGETRAB product family is designed specially for use in the field. Various circuit versions have been optimized for measuring circuits and actuators. Screw connections with metric threads or 1/2" enable use in practically all field device systems available around the world.

These products are also ideal for harsh industrial environments. A stable hexagonal tube made of V4A stainless steel acts as the IP67 housing.

This means that certain SURGETRAB versions are also suitable for use in explosion-proofed areas.





## Item designation key

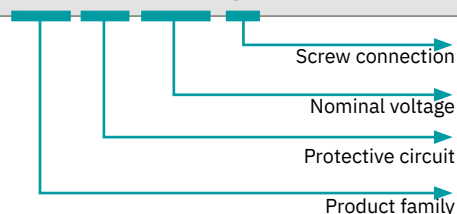

**S-PT-1X2-24DC-1/2**



	Example	Further options
Screw connection	1/2"	3/4" / none = M20
Nominal voltage	24 V DC	48 V DC
Protective circuit	1X2 ONEPAIR (isolated)	2X / 4 / for Ex areas
Product family	SURGETRAB	

# SURGETRAB – robust for applications in the field





Isolated signal circuits, directly grounded	
	
<b>Number of signal wires</b>	<b>2</b>
Rated current	450 mA (55°C)
Maximum continuous voltage $U_c$	40 V DC / 28 V AC
IEC test classification	C1, C2, C3, D1
Max. short-circuit current at the installation location	1 A
Total discharge current $I_{total}$ (8/20) $\mu$ s	20 kA
Resistance per path	2.2 $\Omega$ $\pm$ 10%
Mounting threads: M20	S-PT-1X2-24DC 2880668
Mounting threads: 1/2"	S-PT-1X2-24DC-1/2" 2882569

Isolated signal circuits for potentially explosive application (Ex i)	
	
<b>Number of signal wires</b>	<b>2</b>
Rated current	350 mA (50°C)
Maximum continuous voltage $U_c$	30 V DC / 21 V AC
IEC test classification	C1, C2, C3, D1
Max. short-circuit current at the installation location	350 mA
Resistance per path	2.2 $\Omega$ $\pm$ 10%
Mounting threads: M20	S-PT-EX(I)-24DC 2880671
Mounting threads: 1/2"	S-PT-EX(I)-24DC-1/2" 2882572

# SURGETRAB – robust for applications in the field

- 1
- 2
- 3
- 4
- 5

Surge protection for measurement and control technology

For potentially explosive applications (Ex i / Ex d)			
			
<b>Number of signal wires</b>	<b>2</b>	<b>4</b>	<b>5</b>
Maximum continuous voltage $U_c$	36 V DC / 25 V AC		
IEC test classification	C1, C2, C3, D1		
Max. short-circuit current at the installation location	1 A (non-Ex) / 500 mA (Ex)		
Total discharge current $I_{total}$ (8/20) $\mu$ s	20 kA		
Mounting threads: M20	S-PT-EX-24DC 2800034	S-PT-2XEX-24DC 2800040	S-PT-4-EX-24DC 2800036
Mounting threads: 1/2"	S-PT-EX-24DC-1/2" 2800035	S-PT-2XEX-24DC-1/2" 2800041	S-PT-4-EX-24DC-1/2" 2800037

# Surge protection for information technology

3

## Secure signal transmission in IT networks

Communication via data networks is a part of daily life in all areas of society. The interfaces operate with low signal levels at high frequencies. This makes them particularly sensitive to surge voltages and can lead to the destruction of electronic components in IT systems.



### Universal protection for information technology

The DATATRAB DT product family provides surge protection for many applications:

- High-speed networks up to 10 Gigabit Ethernet
- Networks with RS-485 interface
- Analog and digital interfaces for telecommunications, including DSL

➤ More information starting on page 78



### Compact protection for telecommunications applications

With an overall width of just 6 mm, TERMITRAB complete provides narrow and reliable protection for telecommunications interfaces in the form of the TTC-6-1X2-TELE solution.

- More information starting on page 82
- TERMITRAB complete product family: More information starting on page 52

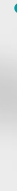

### Intelligent protection for data interfaces

The intelligent PLUGTRAB PT-IQ surge protection solution reliably protects your data cables against surge voltages. The protective circuit has been tailored specially to HF applications.

- More information starting on page 84
- PLUGTRAB IQ product family: More information starting on page 62

## Ideal protection for every interface

### Simple protection of all network interfaces

With the DATATRAB family, you can easily protect your networks and telecommunications systems against damage due to overvoltage. Whether connected directly to the computer as an adapter or with just a click onto the DIN rail, DATATRAB is installed in no time.



### Your advantages

- ✓ Conformance with all standards – both for surge protection and for high-speed networks
- ✓ Protection for all common applications and signals with the complete product portfolio
- ✓ Versatile use with application-specific designs and connection technologies

# DATATRAB – universal protection for information technology



## Versatile

The DATATRAB product family features protective devices ideal for the RJ11/12, RJ45, and D-SUB interfaces.



## Fast

Used in IT systems with up to 10 Gbps (CAT6 / CLASS Ea) and in telecommunications networks with 50 Mbps (VDSL).

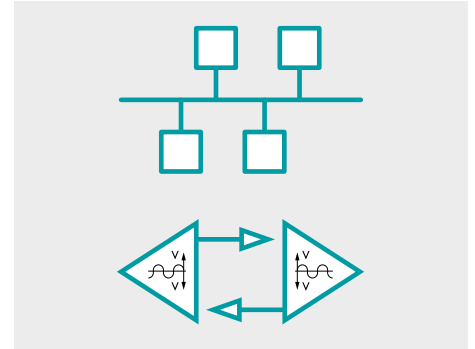

## Universal

For all common applications: Ethernet, Profinet, DS1, DSL, analog telecommunications, RS-485, V.24, etc.

## Universal protection for data interfaces

DATATRAB DT reliably protects high-speed networks against damage caused by surge voltages. In just one device, the DT-LAN-CAT.6+ can manage various data protocols at high transmission rates such as Ethernet, “Power over Ethernet” (PoE), PROFINET, and DS1.

The housing has a ground connection snap-on foot into which the ground connection cover with equipotential bonding line is inserted. DATATRAB can therefore be used as an adapter or as a DIN rail module, after removing the ground connection cover.

The protective devices must guarantee short response times to quickly limit surge voltages to safe values, without impairing signal quality. In addition, the protective devices support system-specific connections, such as RJ45 or D-SUB connectors, and all types of network topologies.

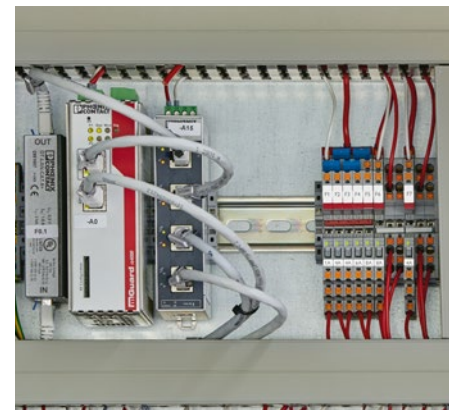

DATATRAB in use

## Ultra-slim or also pluggable

The TERMITRAB complete (starting on page 44) and PLUGTRAB IQ (starting on page 56) product families also include products for protecting your analog and digital telecommunications interfaces.

With an overall width of just 6.2 mm, the TTC-6-1X2-TELE is ideal for VDSL and G.fast applications with up to 300 Mbps with VDSL and 1.5 Gbps with G.fast. Both product families also include products with protective circuits specially tailored to HF applications.







TERMITRAB complete



PLUGTRAB-IQ

# Surge protection for information technology / DATATRAB





Ethernet/PROFINET			
			
<b>Connection technology</b>	<b>RJ45</b>	<b>RJ45</b>	<b>RJ45</b>
Type in accordance with IEC	B2, C1	B2, C2, D1, C1	B2, C1, C2, C3, D1
Maximum continuous operating voltage $U_c$	$\pm 5 \text{ V DC } (\pm 57 \text{ V DC/PoE+})$		$\leq 3.3 \text{ V DC } (\pm 60 \text{ V DC/PoE+})$
Rated current	$\leq 1.5 \text{ A } (25^\circ\text{C})$	$\leq 1.5 \text{ A } (25^\circ\text{C})$	$\leq 1.5 \text{ A } (25^\circ\text{C})$
Total discharge surge current $I_{\text{total}}$	—	8 kA	10 kA
Type	D-LAN-CAT.5-FP	D-LAN-CAT.5-HC	DT-LAN-CAT.6+
Item no.	<a href="#">2800723</a>	<a href="#">2800763</a>	<a href="#">2881007</a>

RS-485/PROFIBUS		
		
<b>Connection technology</b>	<b>D-SUB-9</b>	<b>Screw connection and D-SUB-9</b>
Type in accordance with IEC	B2, C1, C2, C3, D1	C1, C3, B2
Max. Continuous voltage $U_c$	12 V DC	5.2 V DC
Rated current	$\leq 380 \text{ mA } (25^\circ\text{C})$	250 mA (25°C)
Total discharge surge current $I_{\text{total}}$	10 kA	350 A
Resistance per path	3.3 $\Omega$ 10%	—
Type	DT-UFB-485/BS	D-UFB-PB
Item no.	<a href="#">2920612</a>	<a href="#">2880642</a>

# Surge protection for information technology / DATATRAB





1  
2  
3  
4  
5

Surge protection for information technology



TELEKOM				
				
<b>Connection technology</b>	<b>Push-in connection</b> <span style="background-color: #e91e63; color: white; padding: 2px;">NEW</span>	<b>RJ45 / COMBICON</b>	<b>RJ45 / COMBICON</b>	<b>Push-in connection</b>
Type in accordance with IEC	B2, C1, C2, C3, D1			
Maximum continuous operating voltage $U_c$	60 V DC	185 V DC / 130 V AC		60 V DC
Rated current	200 mA (30 V DC, 70°C) / 100 mA (>30 V DC)	$\leq 380$ mA (25°C)		200 mA
Total discharge current $I_{total}$ (8/20) $\mu$ s	12 kA (terminal)	10 kA		
Resistance per path	6 $\Omega$	3.3 $\Omega$ 10%	3.3 $\Omega$ 20%	6 $\Omega$
Type	DT-TELE-WM-RJ45-PT-I	DT-TELE-RJ45	DT-TELE-SHDSL	TTC-6-1X2-TELE-PT
Item no.	<a href="#">1464188</a>	<a href="#">2882925</a>	<a href="#">2801593</a>	<a href="#">1077106</a>

## Surge protection for information technology / TERMITRAB complete

### RS-485/PROFIBUS, directly grounded

				
<b>Pluggable</b>	<b>Yes</b>	<b>Yes</b>	<b>No</b>	<b>No</b>
<b>Knife disconnection</b>	<b>Yes</b>	<b>No</b>	<b>Yes</b>	<b>No</b>
Number of signal wires	3	3	3	3
Rated current	600 mA (56°C)		600 mA (40°C)	
Maximum continuous voltage $U_c$	15 V DC / 10 V AC			
IEC test classification	C1, C2, C3, D1			
Pulse discharge current $I_{imp}$ (10/350) $\mu$ s	0.5 kA			
Total discharge current $I_{total}$ (8/20) $\mu$ s	10 kA			
Resistance per path	1.65 $\Omega$ $\pm$ 20%			
Push-in connection	TTC-6P-3-HF-M-12DC-PT-I <a href="#">2906756</a>	TTC-6P-3-HF-12DC-PT-I <a href="#">1065313</a>	TTC-6-3-HF-M-12DC-PT-I <a href="#">2906732</a>	TTC-6-3-HF-12DC-PT <a href="#">1065316</a>
Screw connection	TTC-6P-3-HF-M-12DC-UT-I <a href="#">2906744</a>		TTC-6-3-HF-M-12DC-UT-I <a href="#">2906721</a>	



### RS-485/PROFIBUS, indirectly grounded



		
<b>Pluggable</b>	<b>Yes</b>	<b>No</b>
<b>Knife disconnection</b>	<b>No</b>	<b>No</b>
Number of signal wires	3	3
Rated current	600 mA (56°C)	600 mA (40°C)
Maximum continuous voltage $U_c$	15 V DC / 10 V AC	15 V DC
IEC test classification	C1, C2, C3, D1	
Pulse discharge current $I_{imp}$ (10/350) $\mu$ s	0.5 kA	
Total discharge current $I_{total}$ (8/20) $\mu$ s	10 kA	
Resistance per path	1.65 $\Omega$ $\pm$ 20%	
Push-in connection	TTC-6P-3-HF-F-12DC-PT-I <a href="#">1065314</a>	TTC-6-3-HF-F-12DC-PT <a href="#">1109712</a>

# Surge protection for information technology / TERMITRAB complete

1  
2  
3  
4  
5



Surge protection for information technology

For potentially explosive applications, PROFIBUS PA fieldbus systems		
		
<b>Pluggable</b>	<b>Yes</b>	<b>No</b>
<b>Knife disconnection</b>	<b>Yes</b>	<b>Yes</b>
Number of signal wires	3	3
Rated current	600 mA (40°C)	
Maximum continuous voltage $U_c$	30 V DC	
IEC test classification	C1, C2, C3, D1	
Pulse discharge current $I_{imp}$ (10/350) $\mu$ s	0.5 kA	
Total discharge current $I_{total}$ (8/20) $\mu$ s	10 kA	
Resistance per path	1.65 $\Omega$ $\pm$ 20%	
Screw connection	TTC-6P-3-HF-F-M-EX-24DC-UT-I <a href="#">2906828</a>	TTC-6-3-HF-F-M-EX-24DC-UT-I <a href="#">2906823</a>

Remote signaling sets and modules		
		
<b>Description</b>	<b>Remote signaling module – transmitter</b>	<b>Remote signaling module – receiver</b>
Push-in connection	TTC-6-FMTX-PT <a href="#">1193565</a>	TTC-6-FMRX-PT <a href="#">1193571</a>
Screw connection	TTC-6-FMTX-UT <a href="#">1193555</a>	TTC-6-FMRX-UT <a href="#">1193557</a>

# Surge protection for information technology / PLUGTRAB-IQ



## RS-485/PROFIBUS, directly grounded

COMPLETE line					
	<b>Number of signal wires</b>		<b>3</b>		<b>5</b>
<b>Rated current</b>		600 mA (40°C)			
<b>Maximum continuous voltage U<sub>c</sub></b>		6 V DC / 4 V AC		15 V DC / 10 V AC	
<b>IEC test classification</b>		C1, C2, C3, D1			
<b>Pulse discharge current I<sub>imp</sub></b> (10/350) μs		2.5 kA			
<b>Total discharge current I<sub>total</sub></b> (8/20) μs		20 kA			
<b>Cut-off freq. fg (3dB) 150 ohms</b>		Type 60 MHz			
<b>Resistance per path</b>		1.2 Ω ±5%			
<b>Push-in connection</b>		PT-IQ-3-PB-PT 2801286		PT-IQ-5-HF-12DC-PT 2801293	

## RS-485/PROFIBUS, indirectly grounded

COMPLETE line							
	<b>Number of signal wires</b>		<b>3</b>		<b>3</b>		<b>5</b>
<b>Rated current</b>		600 mA (40°C)					
<b>Maximum continuous voltage U<sub>c</sub></b>		6 V DC / 4 V AC		15 V DC / 10 V AC		15 V DC / 10 V AC	
<b>IEC test classification</b>		C1, C2, C3, D1					
<b>Pulse discharge current I<sub>imp</sub></b> (10/350) μs		2.5 kA					
<b>Total discharge current I<sub>total</sub></b> (8/20) μs		20 kA					
<b>Cut-off freq. fg (3dB) 150 ohms</b>		Type 60 MHz					
<b>Resistance per path</b>		1.2 Ω ±5%					
<b>Push-in connection</b>				PT-IQ-3-HF+F-12DC-PT 2801289		PT-IQ-5-HF+F-12DC-PT 2801295	
<b>Screw connection</b>		PT-IQ-3-PB+F-UT 2800994					

# Surge protection for information technology / PLUGTRAB-IQ

TELEKOM	
	
<b>Connection technology</b>	<b>Push-in connection</b>
Description	Double wire (loop), floating, connection 9/10 directly grounded, e.g., for DSL applications
Type in accordance with IEC	B2, C1, C2, C3, D1
Maximum continuous operating voltage $U_c$	180 V DC
Rated current	150 mA (25°C)
Pulse discharge current $I_{imp}$ (10/350) $\mu$ s	2.5 kA
Total discharge current $I_{total}$ (8/20) $\mu$ s	20 kA
Resistance per path	1.2 $\Omega$ $\pm$ 5%
Type	PT-IQ-1X2-TELE-PT
Item no.	2801290

Supply and remote signaling modules		
		
<b>Connection technology</b>	<b>Push-in connection</b>	<b>Screw connection</b>
Type	PT-IQ-PTB-PT	PT-IQ-PTB-UT
Item no.	2801296	2800768

# Protection for transmitter and receiver systems

## High availability for exposed antenna systems

Transmitting and receiving systems are particularly at risk of overvoltages because long antenna cables, which often span several buildings, and the antennas themselves are directly exposed to atmospheric discharges. This means that overvoltages can reach sensitive interfaces.



### Protection for satellite receiver technology antenna inputs

Good shielding properties are vital for “clean” transmission. The robust metal housings provide ideal shielding properties and are also suitable for use in harsh industrial environments.

➤ More information starting on page 88



### Protection for antennas with N, F, and SMA connection

The protective devices conform to standards in all performance classes. This applies for coarse protection in accordance with Category D1 and for fine protection in accordance with Category C2 and C1.

➤ More information starting on page 89

# Surge protection for transmitter and receiver systems

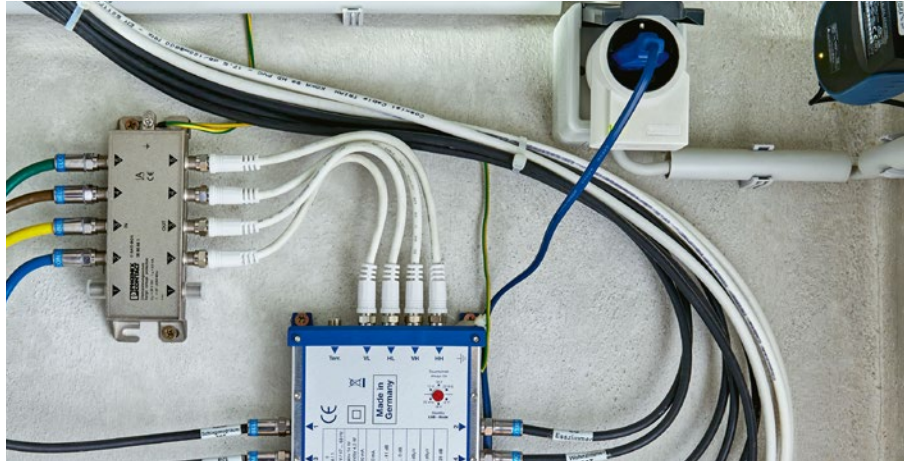

## Protection for home applications

Satellite systems for TV reception are installed in very many residential homes, whether for single families or several families. The C-SAT-Box can be connected directly to the multi-switch to prevent the antenna splitter on satellite equipment from failing due to overvoltage.



## Your advantages

- ✔ No signal interference with optimum transmission properties
- ✔ Protection of digital and analog signals with universal protective circuit
- ✔ Easy installation with surface mounting

TV	
	
<b>Connection method</b>	<b>F connector</b>
Frequency range	47 MHz ... 2.5 GHz
Type in accordance with IEC	B2, C1, C2, C3, D1
Maximum continuous voltage $U_c$	20 V DC
Rated current	400 mA
Pulse discharge current $I_{imp}$ (10/350) $\mu$ s	0.5 kA
Total discharge current $I_{total}$ (8/20) $\mu$ s	10 kA
Resistance per path	3.3 $\Omega$ $\pm$ 20%
Connection type: Female to female	C-SAT-BOX <a href="#">2880561</a>

# Surge protection for transmitter and receiver systems

## Protection for industrial applications

Cables with a coaxial structure and therefore favorable EMC properties are also primarily used in industrial antenna systems. However, the danger of surge voltage coupling in antenna cables and potential transfer through to the sensitive interfaces of transmitter and receiver systems is not eliminated. The COAXTRAB product family enables you to significantly increase the availability and operability of the devices in question.



## Your advantages

- ✓ Easy installation with system-compliant connection
- ✓ Use under extreme ambient conditions thanks to robust design
- ✓ Exceptional protective properties with Lambda/4 technology

GSM/LTE/WiMAX				
				
<b>Connection method</b>	<b>N connector 50 Ω</b>	<b>N connector 50 Ω</b>	<b>N connector 50 Ω</b>	<b>N connector 50 Ω</b>
Frequency range	0.8 GHz ... 2.25 GHz	2.4 GHz ... 7.6 GHz	0 Hz ... 6 GHz	0 Hz ... 3 GHz
Type in accordance with IEC	C2, C3, D1	C2, C3, D1	C2, C3, D1	C2, C3, D1
Maximum continuous voltage $U_c$	—	—	70 V DC / 50 V AC	280 V DC
Rated current	5 A (25°C)	5 A (25°C)	10 A	5 A (25°C)
Pulse discharge current $I_{imp}$ (10/350) μs	20 kA	20 kA	1 kA	2.5 kA
Total discharge current $I_{total}$ (8/20) μs	60 kA	60 kA	10 kA	20 kA
Connection type: Female to female	CN-LAMBDA/4-2.25-BB <a href="#">2801057</a>	CN-LAMBDA/4-5.9-BB <a href="#">2838490</a>	CN-UB-70DC-6-BB <a href="#">2803166</a>	CN-UB-280DC-3-BB <a href="#">2801050</a>
Connection type: Male to female	CN-LAMBDA/4-2.25-SB <a href="#">2801056</a>	CN-LAMBDA/4-5.9-SB <a href="#">2800023</a>	CN-UB-70DC-6-SB <a href="#">2803153</a>	CN-UB-280DC-3-SB <a href="#">2801051</a>

# EMC filters

5

## For a reliable power supply

Filters limit high-frequency interference voltages and currents generated by equipment during normal operation and occurring under fault conditions. Using our EMC filters, you ensure smooth operation in environments subject to interference.



### Double protection, one device

SFP2-... products are type 2 surge protective devices with integrated filter circuit. The metal housings improve the protective effect in case of HF interference, and at the same time protect against transient overvoltages.

➤ More information starting on page 95



### EMC protection at just 6 mm

Our ultra-compact EMC filters with a width of just 6 mm offer reliable protection with minimal space requirements – ideal for applications in MCR technology.

➤ More information starting on page 97



### Effective EMC protection for devices

The FIL-... mains filters provide reliable protection against HF interference. With current-coupled coil, X/Y capacitors, additional PE terminal blocks, and screw or Push-in connection, they offer a wide range of possible applications.

➤ More information starting on page 97

# Reliable system operation in environments where interference is an issue

## Sources of interference and its effects

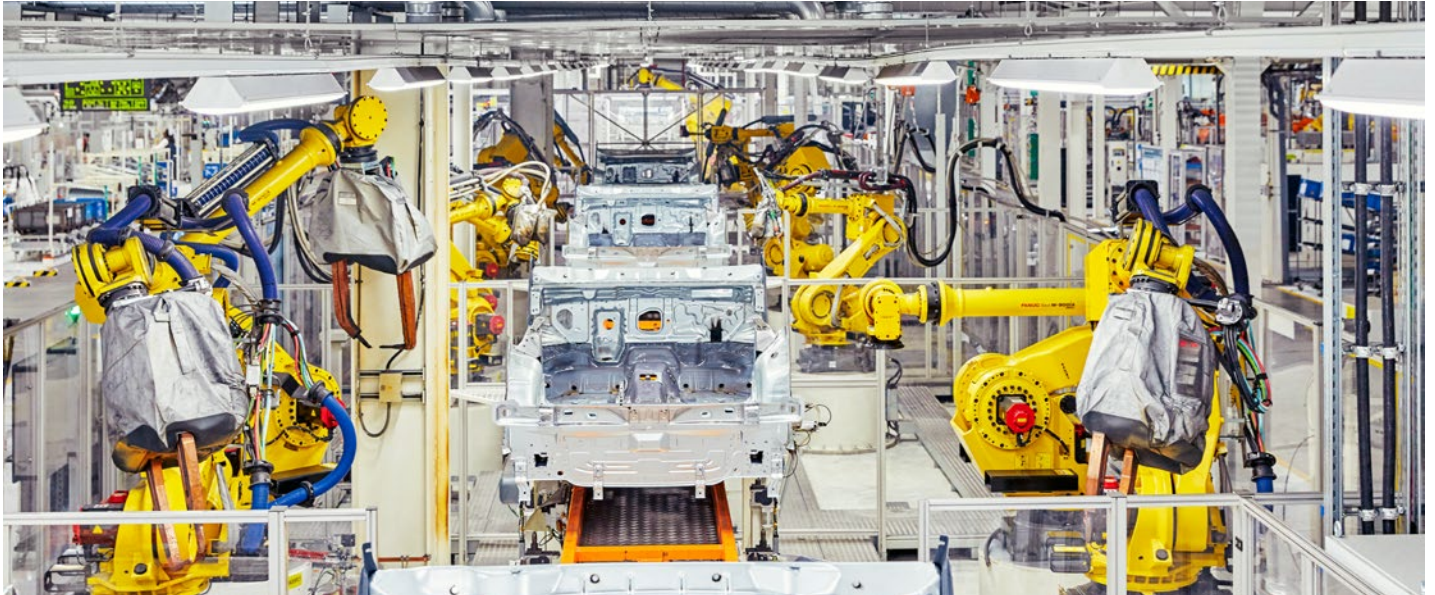

### Conducted interference

Energy efficiency plays an important role in modern electrical systems. Power electronics equipment is increasingly being used to achieve a high level of energy efficiency. Power electronics equipment (e.g., switched-mode power supply units, frequency converters) usually contains switched electronic components. High energy efficiency is achieved due to the high switching frequencies of the electronic components.

High switching frequencies do not only have advantages in energy technology equipment. Frequently, there is also an increase in the generation of high-frequency conducted interference. Power electronics equipment does not just consume electricity. It is usually also a source of high-frequency conducted interference.

Conducted interference is distributed via power cables in the power supply system and can result in malfunctions on sensitive equipment. The conducted interference generated by a single item of power electronics equipment does not usually negatively impact other equipment.

In power supply systems, many items of power electronics equipment are often used together at the same time. The resulting high-frequency conducted interference that is generated quickly mounts up. The extent of this interference can be so great that other items of sensitive equipment can suffer temporary or permanent

malfunctions. In this context, the problem is one of electromagnetic compatibility (EMC).

### EMC filters help against conducted interference

In real-life electrical systems, it is often not possible to replace equipment that causes interference with less disruptive equipment. Nevertheless, it is possible to ensure the satisfactory operation of sensitive equipment by using EMC filters.

In power supply systems, EMC filters help reduce high-frequency conducted interference. This allows sensitive equipment to be operated without malfunctions.

FIL-1S-1 type EMC filters (up to 230 V AC, up to 220 V DC, 1 ... 20 A) are used to protect sensitive single-phase equipment against high-frequency conducted interference.

SFP2-1S-1 type EMC filters (120 V AC, 230 V AC, 5 ... 20 A) are additionally equipped with an integrated surge protective device (SPD). These mains filters are used when sensitive single-phase equipment also needs to be protected against man-made or lightning-related surge voltage or surge current pulses.

### Protection of MCR circuits

High-frequency conducted interference does not just occur in power supply systems, it also occurs in MCR circuits. For example, this interference can be coupled into MCR circuits galvanically, inductively,

or capacitively. These days, high-frequency interference is a common cause of malfunctions in MCR systems. MCR circuits, with a voltage up to 24 V, can be protected effectively by using TTC-6-SFP type EMC filters. These EMC filters also have an integrated surge protective device (SPD).

# Typical applications for EMC filters

## Interference from frequency converters

In industrial applications, the drive motors in robots are controlled via frequency converters. These frequency converters generate high-frequency interference that can affect sensitive equipment. FIL-1S-1 mains filters are used to protect against conducted high-frequency

interference on power supply lines.

If power cables are laid in parallel with MCR circuits, there is a danger of RF interference being coupled into the MCR circuits. Filters of the type TTC-6-SFP protect against this.

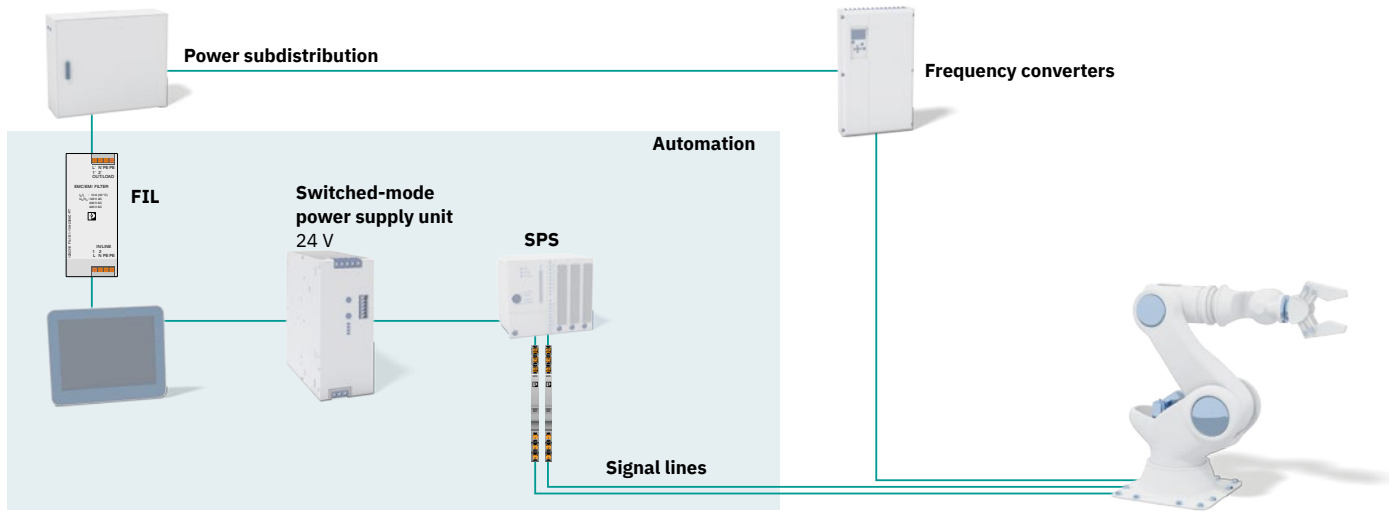

## Interference from LED drivers

These days, LEDs are used in a variety of ways in energy-efficient lighting systems. LEDs always require an LED driver. Depending on their technical design, LED drivers can be a major source of high-frequency conducted interference. The interference generated by LED drivers

can result in malfunctions on sensitive equipment such as automation technology equipment. FIL-1S-1 type EMC filters are used to protect against high-frequency conducted interference on power supply cables.

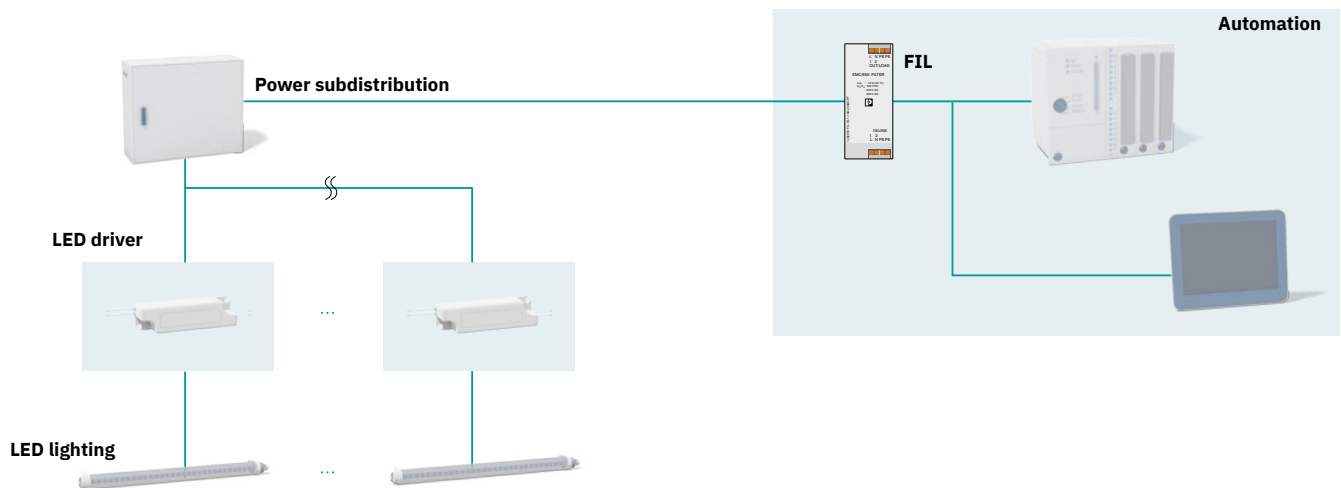

## EMC filters with surge protection

For the reliable operation of your systems

SFP2 ... are EMC filters with integrated surge protection in metal housing for an improved filter effect and EMC-optimized installation. They provide protection against high-frequency interference and transient overvoltages on the input and output side of the filter.







# Product overview

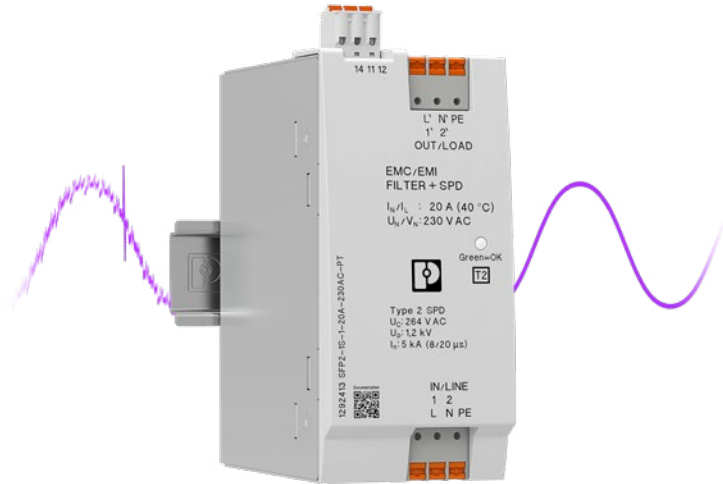

## Double protection

Conventional filters only protect against high-frequency interferences, but not against overvoltage pulses. For effective protection, additional surge protection components are needed. SFP2 filters provide effective protection against overvoltage and high-frequency interference due to a surge protection circuit that protects both the input and output side of the filter.



### EMC filters with surge protection

				
Nominal load current	<b>5 A</b>	<b>10 A</b>	<b>15 A</b>	<b>20 A</b>
Type	SFP2-1-5A-120AC	SFP2-1-10A-120AC	SFP2-1-15A-120AC	SFP2-1-20A-120AC
Push-in connection	<a href="#">1292458</a>	<a href="#">1292455</a>	<a href="#">1292450</a>	<a href="#">1292419</a>
Screw connection	<a href="#">1292315</a>	<a href="#">1292457</a>	<a href="#">1292453</a>	<a href="#">1292421</a>

			
Nominal load current	<b>6 A</b>	<b>10 A</b>	<b>20 A</b>
Type	SFP2-1-6A-230AC	SFP2-1-10A-230AC	SFP2-1-20A-230AC
Push-in connection	<a href="#">1292417</a>	<a href="#">1292414</a>	<a href="#">1292413</a>
Screw connection	<a href="#">1292418</a>	<a href="#">1292416</a>	<a href="#">1292605</a>

## EMC filters provide an improved filter effect

### Against high-frequency interference

Thanks to the additional PE terminals for the separate connection to the local protective bonding, the FIL... EMC filters provide an improved filter effect against the ground potential. This means that a good level of protection against high-frequency interference can be achieved even with filters in plastic housing.



### Simple and flexible installation

Thanks to the simple DIN rail mounting and the variable connection technology, using the filters in the control cabinet is child's play. To connect the EMC filters, you can choose between fast Push-in connection technology or proven screw connection.





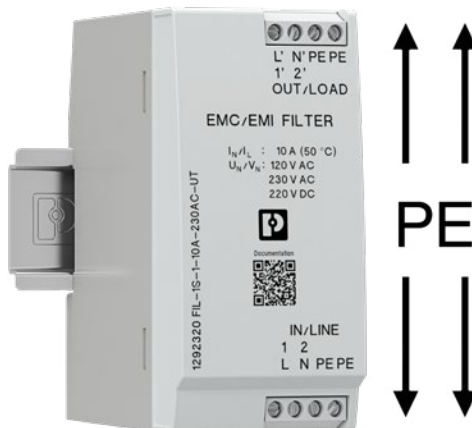

# Product overview

## EMC-optimized installation

The connection of the EMC filters to the local protective bonding is realized by additional PE terminal points. This improves the filter effect for high-frequency interferences between the active conductors and the ground potential. This way, an EMC-optimized installation and an improved protective effect is also achieved for EMC filters in plastic housings.



EMC filters					
					
Nominal load current	<b>1 A</b>	<b>3 A</b>	<b>6 A</b>	<b>10 A</b>	<b>20 A</b>
Type	FIL-1S-1-1A-230AC	FIL-1S-1-3A-230AC	FIL-1S-1-6A-230AC	FIL-1S-1-10A-230AC	FIL-1S-1-20A-230AC
Push-in connection	<a href="#">1292328</a>	<a href="#">1292326</a>	<a href="#">1292321</a>	<a href="#">1292319</a>	<a href="#">1292316</a>
Screw connection	<a href="#">1292329</a>	<a href="#">1292327</a>	<a href="#">1292323</a>	<a href="#">1292320</a>	<a href="#">1292318</a>

## EMC filters with integrated surge protection for applications in MCR technology

With an overall width of just 6 mm, the filters in the TERMITRAB complete family provide the ideal protection against high-frequency interference for applications in measurement and control technology. Due to the integrated surge protection circuit, the narrow filters enable additional fine protection against transient overvoltages.

TTC-6-SFP-24AC-PT  
Item no. [1316312](#)



# Power Reliability – endless possibilities

## Solutions for superior system availability

Increasing electrification, networking, and automation means a growing dependency on reliable power supply solutions. For efficient system operation, we offer you solutions that combine surge protection, EMC filters, energy measuring devices, power supplies, and device circuit breakers. Choose Phoenix Contact, a partner who provides you with holistic concepts for high system availability.



### Surge protection

Our coordinated product portfolio for surge protection enables the implementation of protection concepts for almost any application.



### EMC filters

The EMC filters limit and filter high-frequency interference voltages and currents for an EMC compliant power supply.

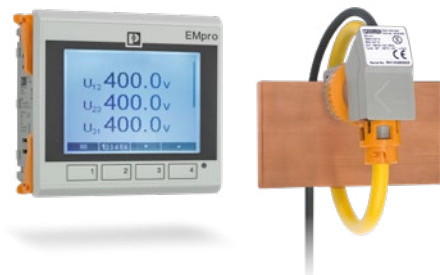

### Energy monitoring

Efficient monitoring, providing the basis for your energy management. Our coordinated measuring devices enable efficient energy data acquisition.



Power Reliability



### Power supplies

Supply your applications safely and reliably. Choose from our range: AC/DC power supplies, DC/DC converters, DC/AC inverters, and power electronics.



### Redundancy modules and UPS

Prevent system downtimes and power failures with our redundancy modules and uninterruptible power supplies.



### Device circuit breakers

Protect your equipment against overload and short circuit with electronic, thermal-magnetic, and thermal device circuit breakers.

## Open communication with customers and partners worldwide

Phoenix Contact is a global market leader based in Germany. We are known for producing forward-thinking products and solutions for the comprehensive electrification, networking, and automation of all sectors of the economy and infrastructure. With a global network, we maintain close relationships with our customers, something we believe is essential for our common success.

You can find your local partner at  
[phoenixcontact.com](https://phoenixcontact.com)

