



Digitalization
Industrie 4.0

Smart Production
E-Mobility
Smart Energy

Energy Efficiency
Smart Infrastructure
Smart Buildings
Renewables

Antonio Gordillo

IMA

Junio 2021

Welcome

Controladores

Phoenix Contact



Webinars

Agenda

- Controladores Inline
 - Controladores Axioline
 - Controladores RFC
 - Controladores PLCnext Technology
 - Controladores de Seguridad
 - Controladores tipo Software
 - Tecnología PLCnext
-

PLCnext Technology
Designed by Phoenix Contact



PLC's Inline
ILC 100

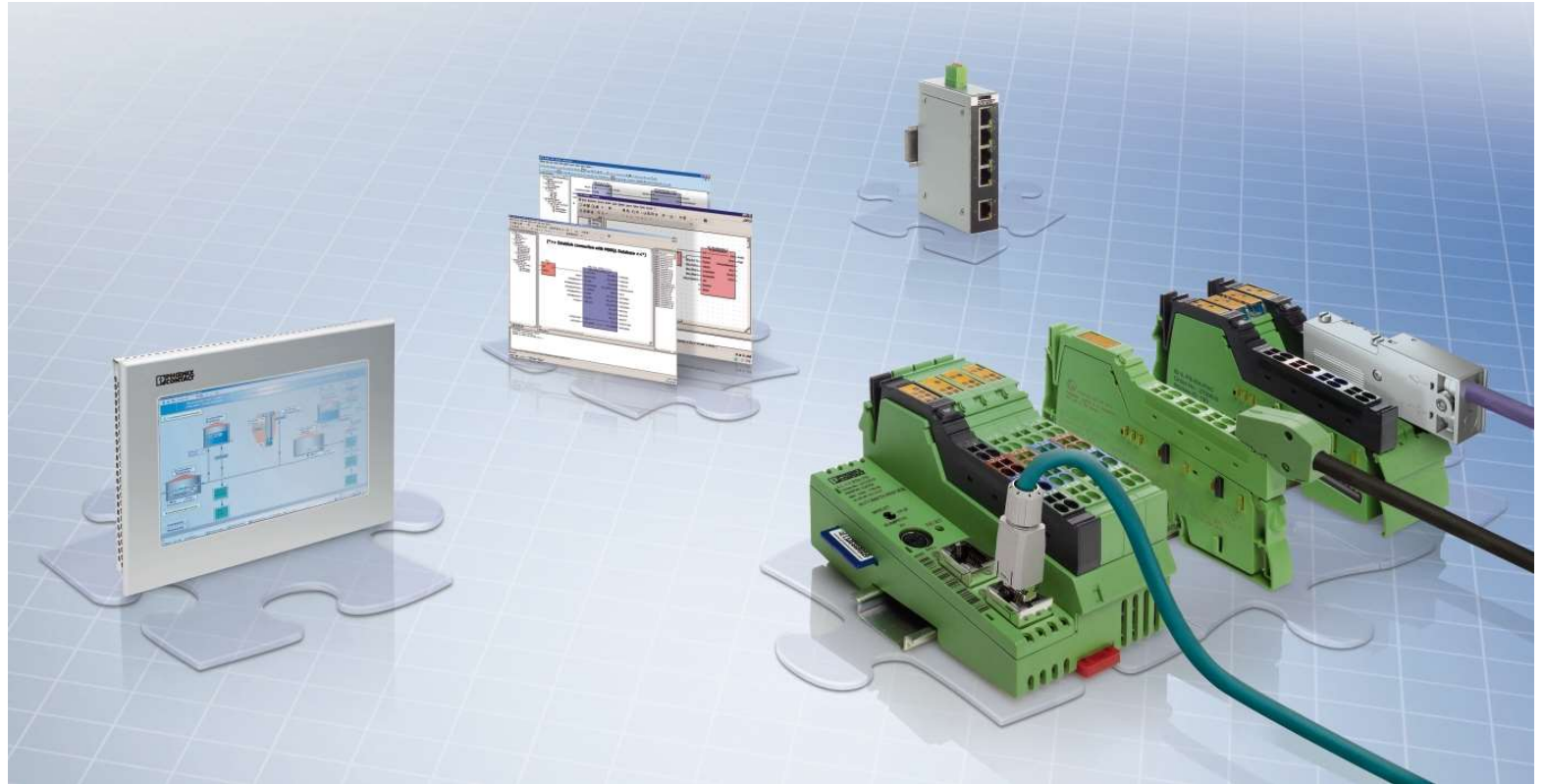

Controladores Inline

Advanced Training

Modular Inline controllers – General data

IEC 61131-3

**PROFI
NET**

Web Server

FTP-Server



Parameterization
memory up to 2GB



Real-time clock (buffered)



Modular Inline controller – differences

	1x1 ETH	1x1 GSM	1x1 ME AN INC	3xx
Engineering	PC Worx or PC Worx Express	PC Worx or PC Worx Express	PC Worx or PC Worx Express	PC Worx
Profinet	Device	-	Device	Controller/Device
Memory card	Optional SD-Flash	Optional SD-Flash	Optional SD-Flash	Required CF card
Modbus TCP	Server/Client	Server/Client	Server/Client	-
HTML5	✓	-	✓	-
Onboard DI/Os	8/4	16/4	8/4	12/4
Other specials		GPRS/GSM Modem	RS 485/422/ PWM	
			2/2 AIO 2 counter	

Modular Inline controller – differences

	Program memory	Mass storage	Retentive mass storage
ILC 131 ETH (XC*)	192 kByte	192 kByte	8 kByte
ILC 151 ETH (XC*)	256 kByte	256 kByte	8 kByte
ILC 151 GSM/GPRS ILC 171 ETH	512 kByte	512 kByte	48 kByte
ILC 191 ETH ILC 191 ME/AN ILC 191 ME/INC	1 MByte	1 MByte	48 kByte
ILC 350 PN	1 MByte	2 MByte	48 kByte
ILC 370 PN ILC 390 PN	2 MByte	4 MByte	96 kByte

Service and Repair

*XC temperature range: - 40°C – 60°C

Inline I/O system

Inline I/O system - for the control cabinet



Inline – easy, flexible, reliable

Whether it's simple or complex applications, Inline provides flexibility in automation. Always cost-effectively adapted to your requirements.

Inline I/O system

The all-rounder in the control cabinet

Diagnostic LEDs for network and local bus

Network or bus connection

Easy shield connection

Color coding of the terminal points simplifies wiring

Flexible through to the field

Quick and easy marking for terminals, conductors, cables, and devices with MARKING system printing system

Increased system safety with independently protected and separately switched station segments thanks to targeted segmentation

Easy handling

- Status and diagnostic LEDs
- Color coding to easily distinguish between I/O functions
- Clearly numbered terminal points

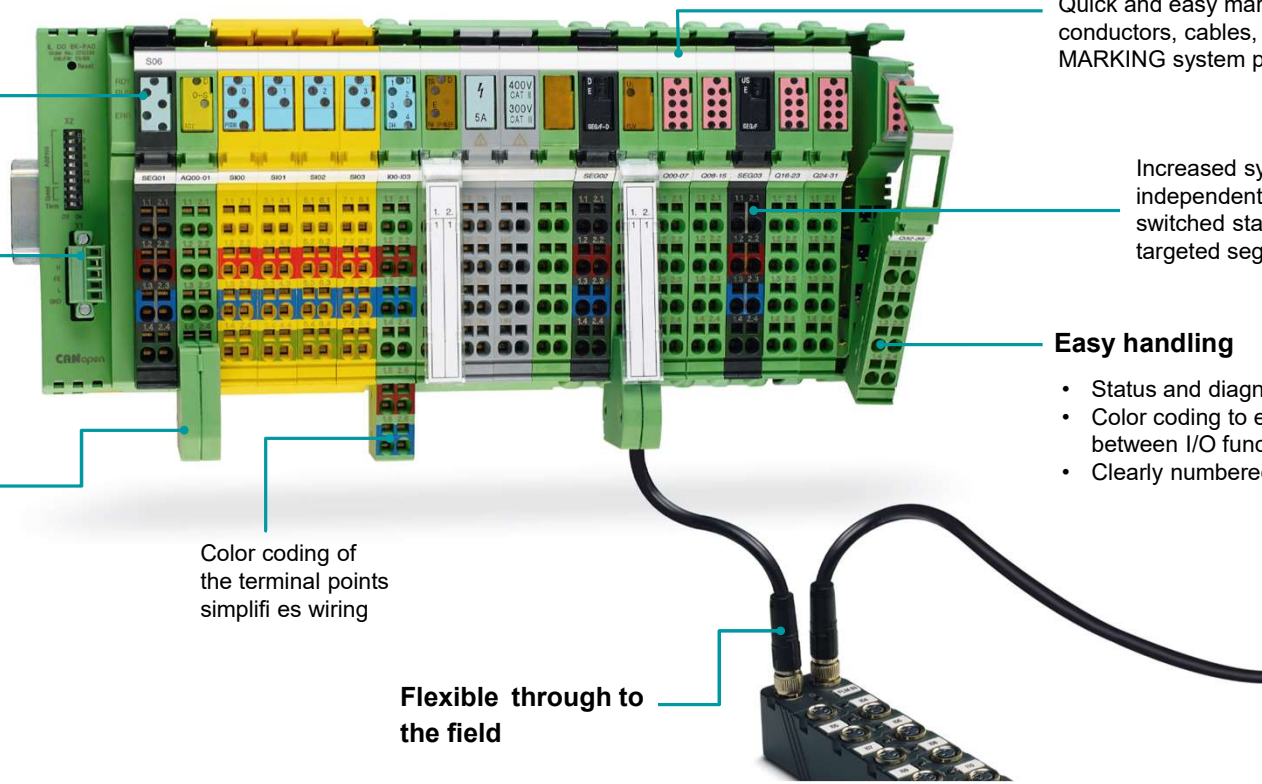

Inline I/O system

Controller, bus coupler or I/O terminals



CANopen
EtherCAT
EtherNet/IP
PROFINET
PROFIBUS
INTERBUS
sercos
the automation bus
DeviceNet
Modbus



ILC 100

Project+ Developing Proposals.

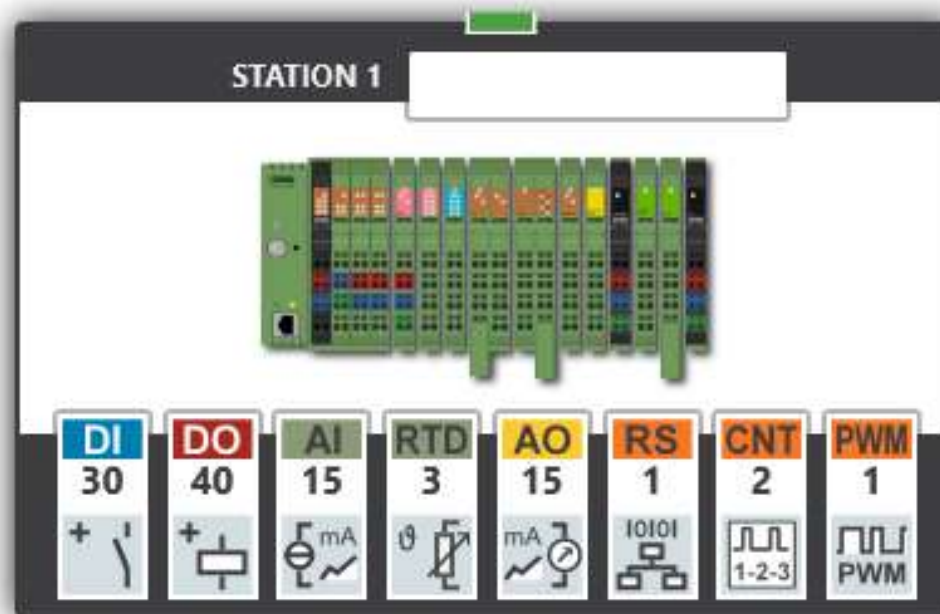

Advanced Training

Special Controller: ILC 2050 BI

- New application fields: Infrastructure, energy & building
- Integrated: 4x LAN, 2x USB & 2x RS-485 interfaces
- Programming with Niagara 4 Framework
 - Expandable by self-programmed functions
- Supported protocols:

niagara
framework



ILC 2050 BI

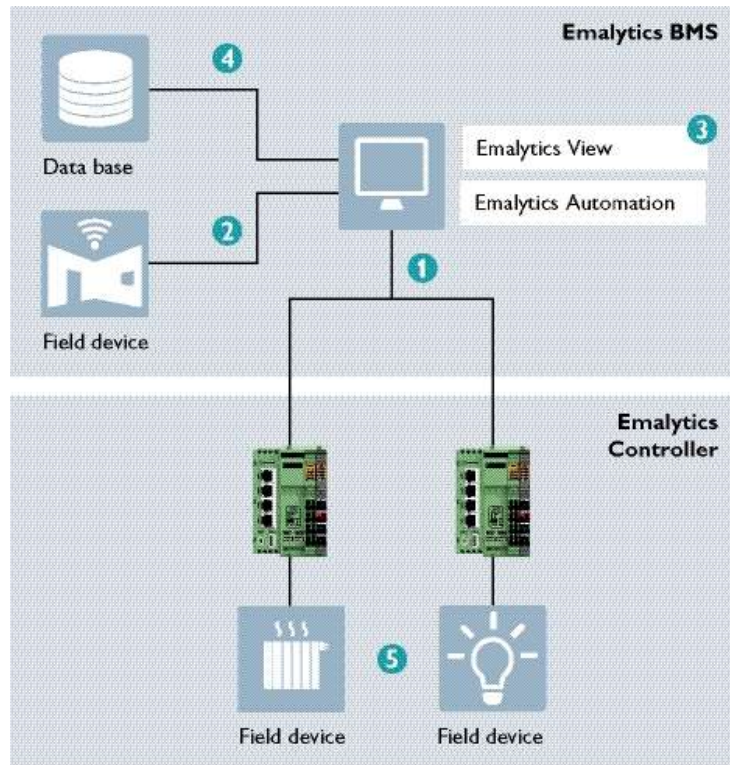

Emalytics platform Building management system application

One tool for integration, engineering, visualization from reporting through to analysing



Building management

- User-oriented room automation
- Cross-utility supply concept (HVAC)
- Predictive maintenance
- Detailed error message management
- Individual integration of SAP, room booking systems and production processes



Energy monitoring

- Power generation and distribution control
- Energy management in accordance with DIN EN ISO 50001
- EnEV German Energy Conservation Regulations support for your property
- Cost-center assignment to the respective loads
- Preferred integration of your own energy sources, for example using the waste heat from your CHP



Area management

- Flexible assignment
- Support of automatic cleaning processes
- Ready for indoor navigation
- Property management
- Freely-scalable system – from room automation through to energy flow control



Cloud service

- Cloud-to-cloud communication
- App-based services
- Technical monitoring
- Safeguarding data integrity
- Protecting the confidentiality of your data
- Ensuring availability for your systems/application



Security

- Safeguarding the building system technology
- Your basis for an IT security concept in accordance IEC 62443

PLC's
AXC



Controladores Axioline

Advanced Training

Modular Axioline controllers – General data

JAVA

IEC 61131-3

**PROFI
NET**

Web Server

FTP-Server



Parameterization
memory up to 2GB



Real-time clock (buffered)



Modular Axioline controller – differences

	1050 (XC*)	3050	Cloud
Engineering	PC Worx or PC Worx Express	PC Worx	PC Worx PC Worx Express
Profinet	Controller/Device	Controller/Device	Controller and Proficloud-Device
Memory card	Optional SD-Flash	Optional SD-Flash	Optional SD-Flash
Modbus TCP	Server/Client	Server/Client	
Ethernet	2x (switched internally)	3x	2x (switched internally)
Other specials			<ul style="list-style-type: none"> ▪ Cloud controller for decentralized use of I/Os ▪ Global availability ▪ Cloud Credits - runtime licenses

Modular Axioline controller – differences

	1050 (XC*)	3050	Cloud
Program memory	1 MByte	4 MByte	1 MByte
Mass storage	2 MByte	8 MByte	1 MByte
Retentive mass storage	48 kByte	128 kByte	48 kByte

*XC temperature range: - 40°C – 70°C

Axioline F I/O system

Axioline F I/O system – for the control cabinet



Axioline – fast, robust, easy

Axioline F enables the shortest response times and is characterized by its particularly robust design and easy handling.

Axioline F I/O system

The specialist in the control cabinet

Colored mark for easy identification

Network or bus interface

Network and local bus diagnostics LEDs

Colored marks for every connection point

Shielded bus socket



Various marking options

Status and diagnostics LEDs on every local bus node

Unique numbering of connection points

Push-in Technology

Pluggable connections

Axioline F I/O system

Controller, bus coupler or I/O modules



AXC 3050

Project+ Developing Proposals.

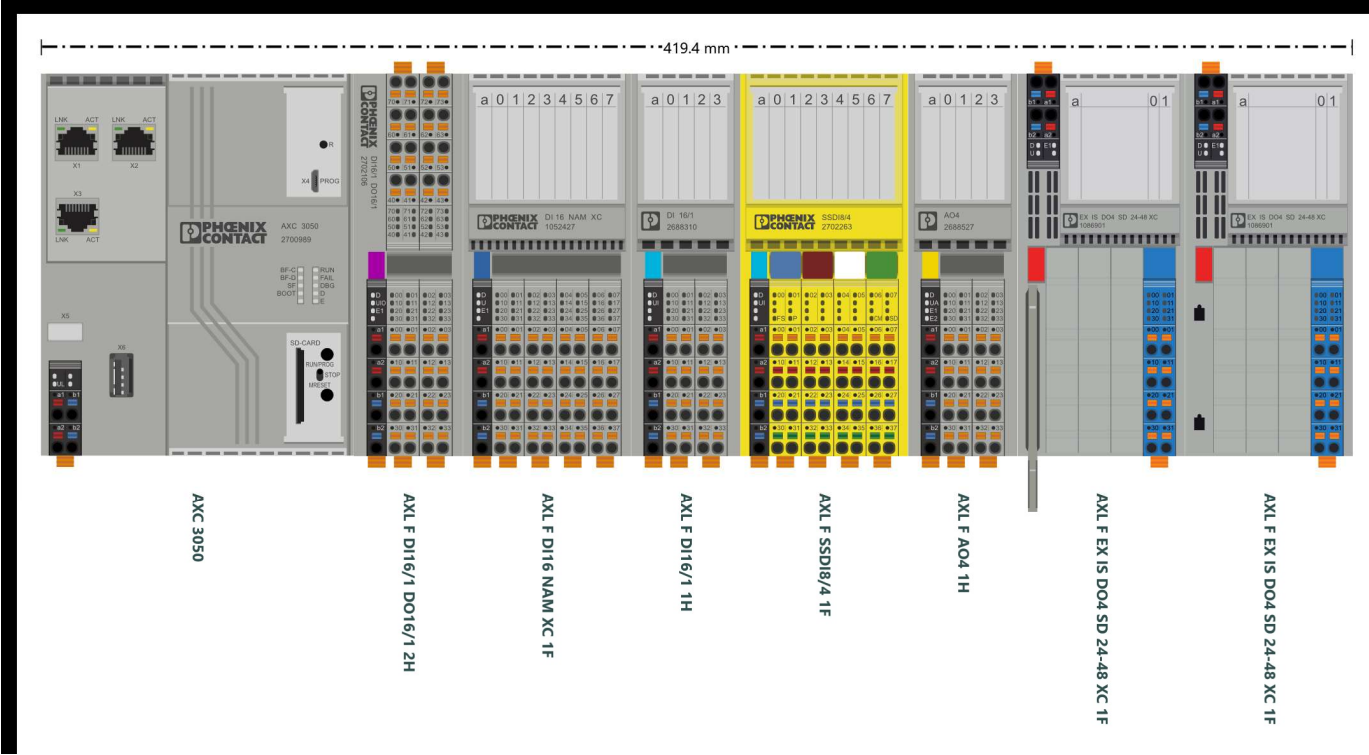

PROJECT+

AXC 1050 architecture

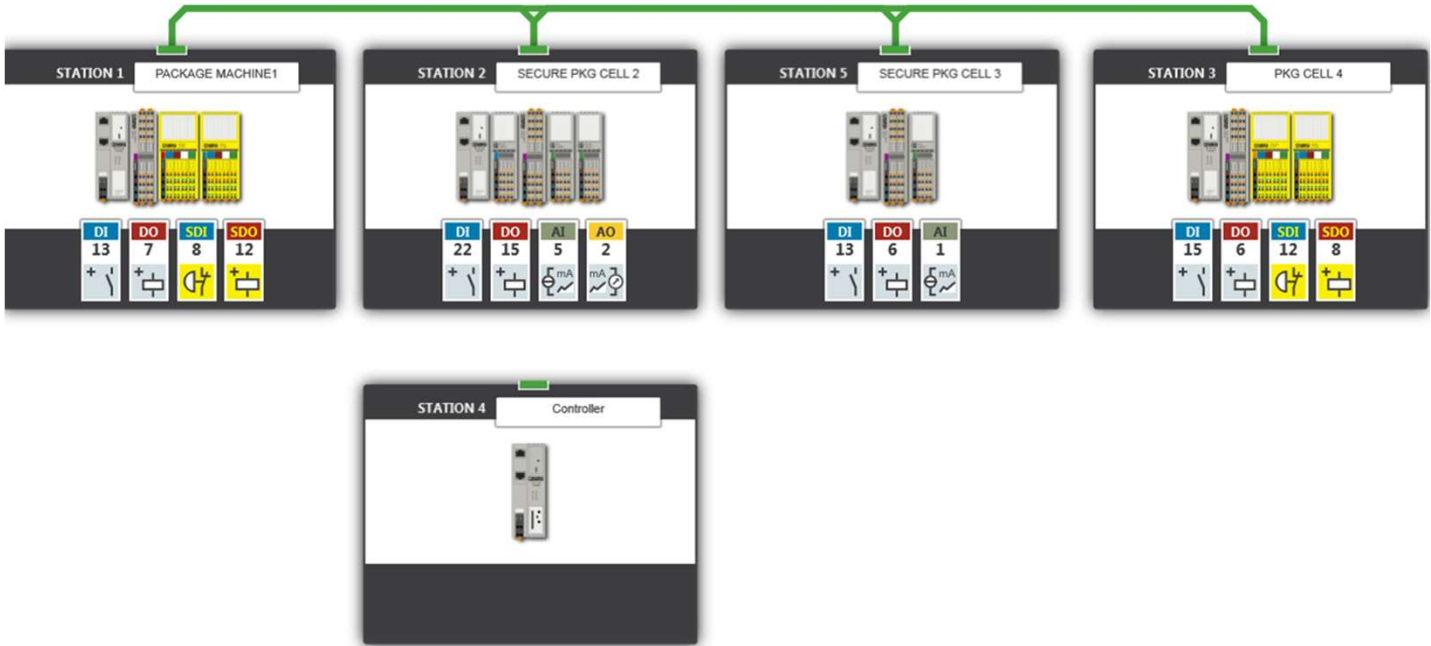

Differentiation of Inline and Axioline F

Inline & Axioline F

Inline

Is

CC



- 2x IP20 I/O systems
- 2x different characteristics

Which I/O system is the best one for the customers solution?

Axioline F

Is fast and robust

Differentiation of Inline and Axioline F

Comparison



Inline

- 9 networks more than 250 modules
- Profisafe and SafetyBridge
- Compact PLCs
- -25°C ... 55°C and -40°C ... 65°C (XC)

Intrinsically safe modules

High flexibility

High functionality

Easy to handle (Inline Eco terminals)

Fine-modular setup



Axioline F

- 7 networks, more than 50 modules
- Profisafe and SafetyBridge
- Compact PLCs
- -25°C ... 60°C and -40°C ... 70°C (XC)

I/Os according IEC 61850

High signal density

Highest robustness

Highest speed

Block-modular setup

Differentiation of Inline and Axioline F

Simple machine building - **Inline (ECO)**



- Interbus, CANopen, Profibus, EtherCAT
- Small granularity of channels
- Safety Bridge
- Easy handling
- Less parametrization (ECO)

Differentiation of Inline and Axioline F

Solar energy - Inline



- Easy automation solution (PLC, I/Os & misc. devices)
- Special communication libraries & devices
- Cost-effective solutions

Differentiation of Inline and Axioline F

Water / Wastewater - **Inline**

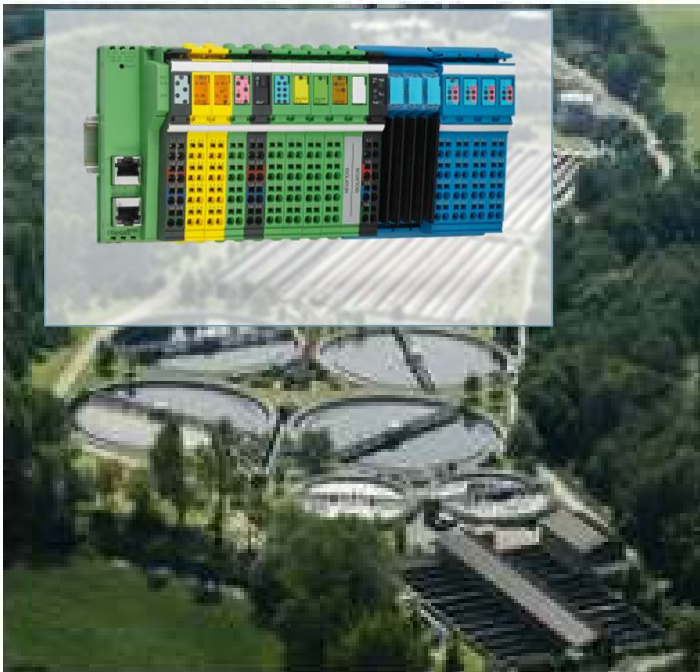

- Easy automation (GSM..., complete solution)
- Special communication libraries & devices
- Cost-effective solutions

Differentiation of Inline and Axioline F

Automotive - Axioline F

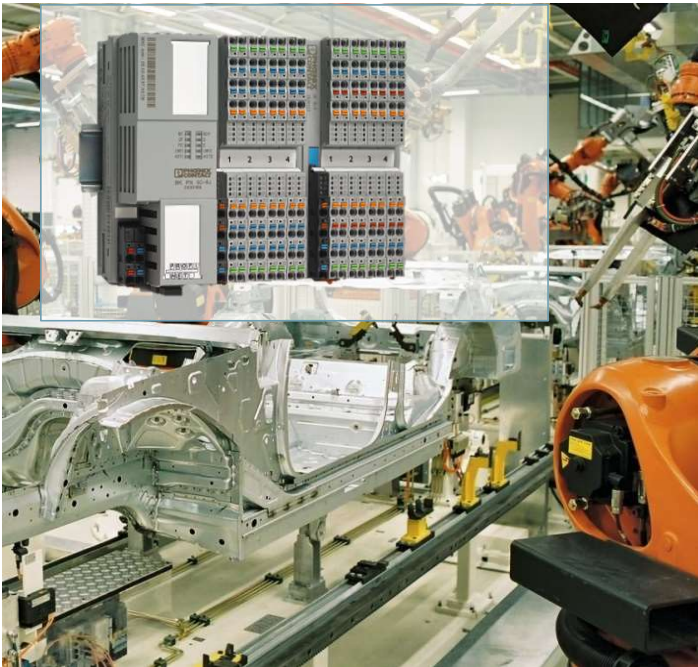

- Profinet
- Fiber Optic communication
- Safety
- High performance
- Enhanced robustness

Differentiation of Inline and Axioline F

Ship building - Axioline F



- Redundant Ethernet bus-coupler for 2 networks
- XC variants with coated PCBs
- Maritime approvals
- Outstanding mechanical robustness

Differentiation of Inline and Axioline F

Enhanced machine building - Axioline F



- Sercos®, Profinet IRT and EtherCAT®
- Safety (SafetyBridge Technology, PROFIsafe)
- High density modules
- Mixed module
- Fast I/Os – fast cycle times

Differentiation of Inline and Axioline F

Wind energy - Axioline F



- Outstanding mechanical robustness
- XC variants with coated PCBs
- Maritime approvals
- Safety

Differentiation of Inline and Axioline F

Energy distribution - Axioline F for IEC61850

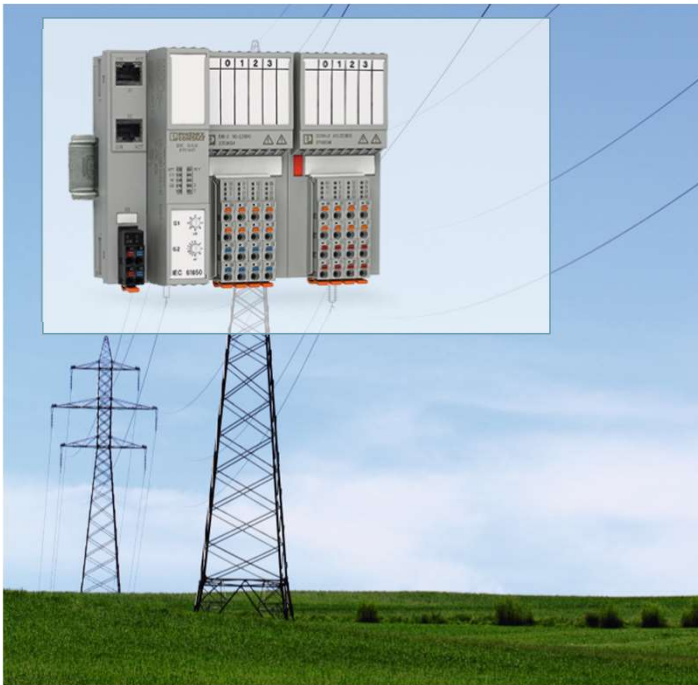

- Bus-coupler for IEC 61850
- 230V DC I/Os
- I/Os with high isolation of >4kV
- Easy installation and wiring

Differentiation of Inline and Axioline F

Infrastructure - Axioline F or Inline

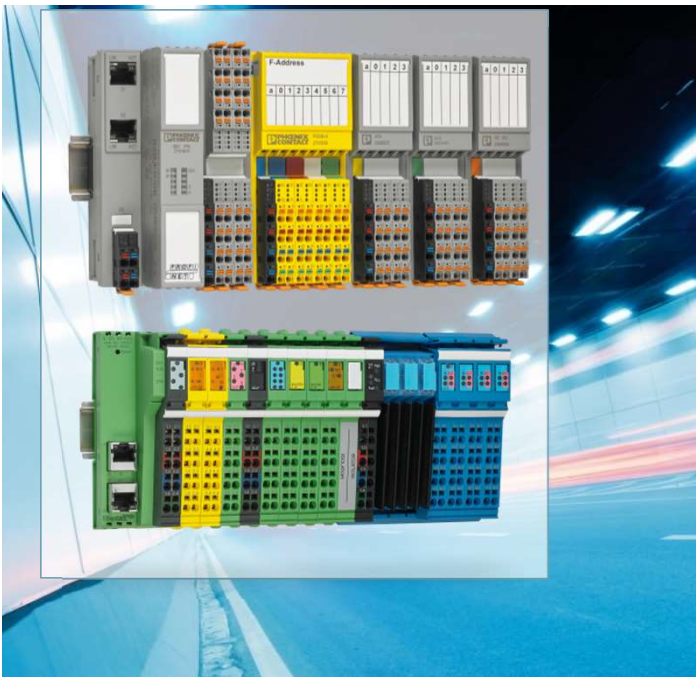

- Redundancy for Profinet and Ethernet (AXL)
- XC variants with coated PCBs (AXL / IL)
- Cost effective (IL)
- Flexibility (IL)

Differentiation of Inline and Axioline F

Automation on an entry level

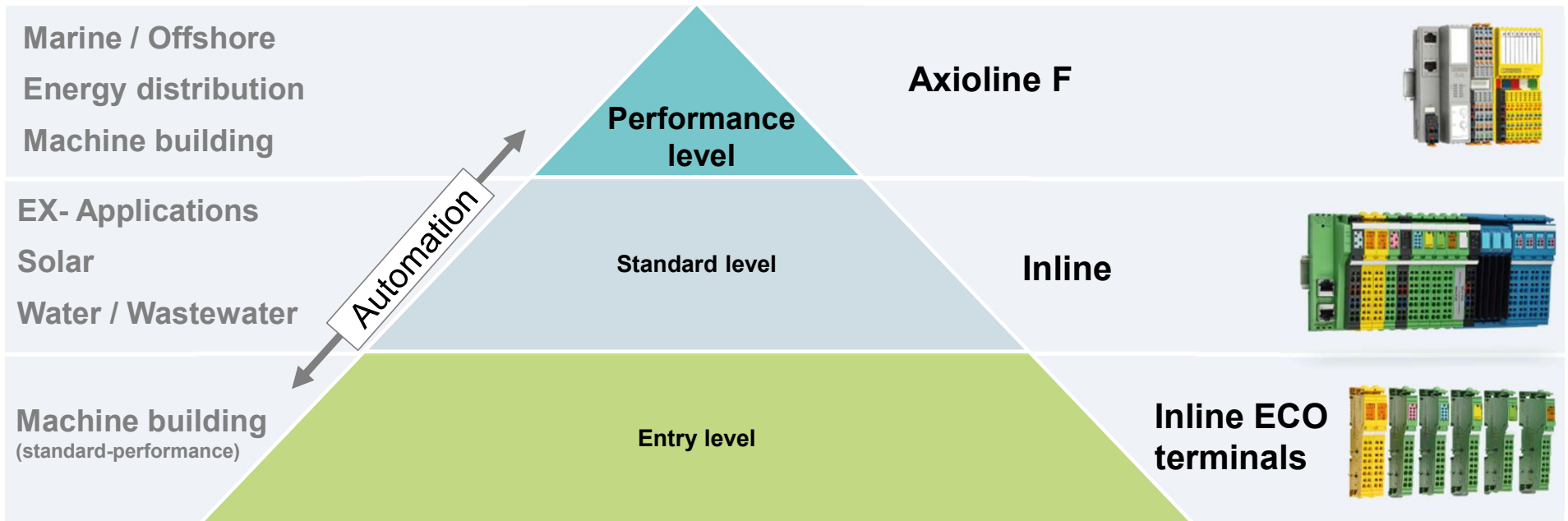



Controladores RFC

Advanced Training

RFC – General data



FTP-Server

IEC 61131-3



Diagnostic display

Web Server



Ethernet 3x

Parameterization
memory up to 2GB

Real-time clock (buffered)



RFCs - differences

	RFC 460R PN 3TX	RFC 470 PN 3TX	RFC 470S PN 3TX
Engineering	PC Worx	PC Worx	PC Worx
Onboard DI/Os	-	5/3	5/3
Interbus	-	✓	✓
Other specials:			
Redundancy	✓  AutoSync Technology [®] <small>Designed by PHOENIX CONTACT</small>	-	-
Safety Controller	-	-	✓ 

RFCs - differences

	RFC 460R PN 3TX	RFC 470 PN 3TX	RFC 470S PN 3TX
Program memory	8 MByte	8 MByte	8 MByte
Mass storage	16 MByte	16 MByte	16 MByte
Retentive mass storage	120 kByte	240 kByte	240 kByte

PLC's redundant
RFC



RFC 460R PN 3TX

PLC Safety

RFC

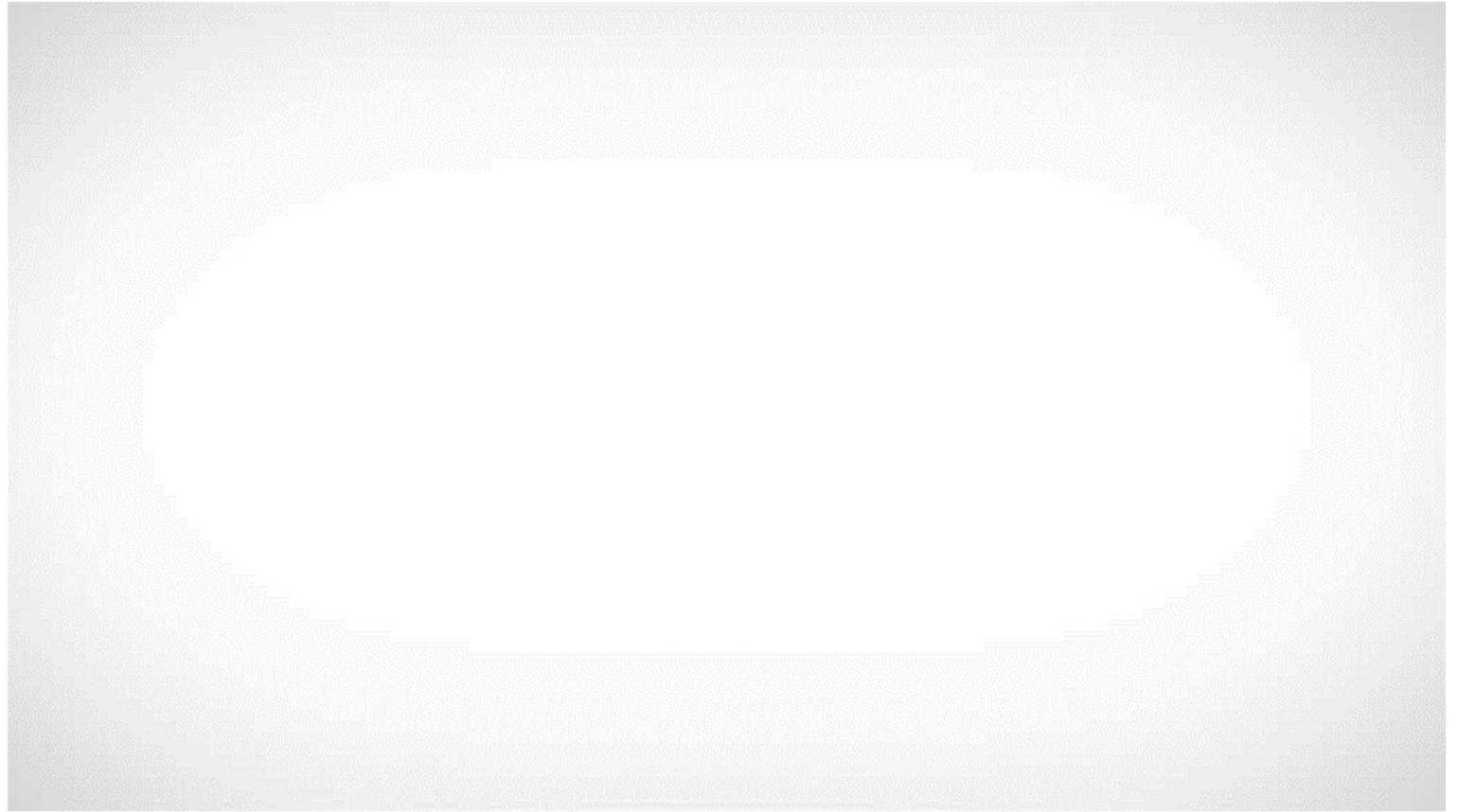

RFC 470S PN 3TX

PLC's

RFC PN Profisafe

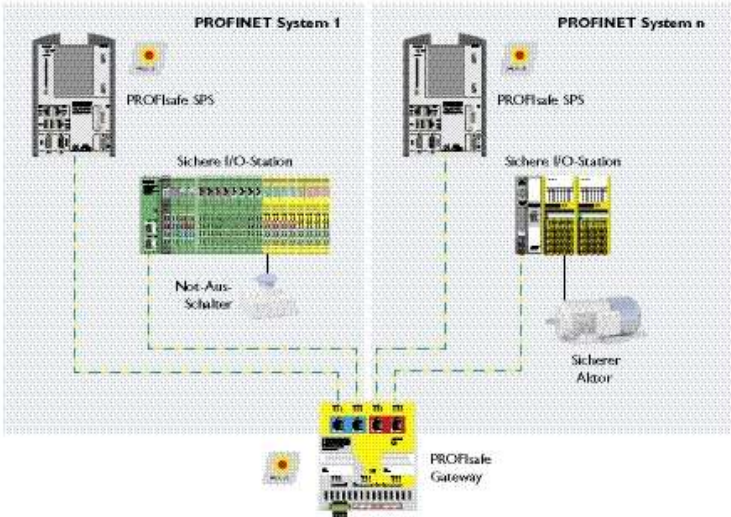



Controladores PLCnext

PLCnext Technology[®]

Designed by PHOENIX CONTACT

Open control platform for flexible automation

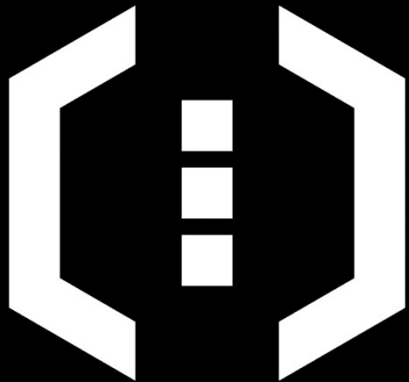

PLCnext Control

Discover flexible
automation



PLCnext Ecosystem – PLCnext Control

PLCnext Control

PLCnext Technology[®]
Designed by PHOENIX CONTACT

PLCnext Technology[®]

Designed by PHOENIX CONTACT

Open control platform for flexible automation



PLCnext Control

Discover flexible
automation

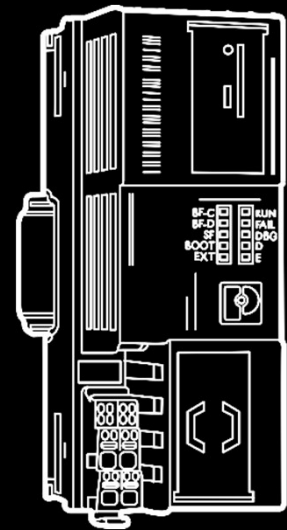

PLCnext Ecosystem – PLCnext Control

PLCnext Control Portfolio Overview

PLCnext Technology [®]
Designed by PHOENIX CONTACT

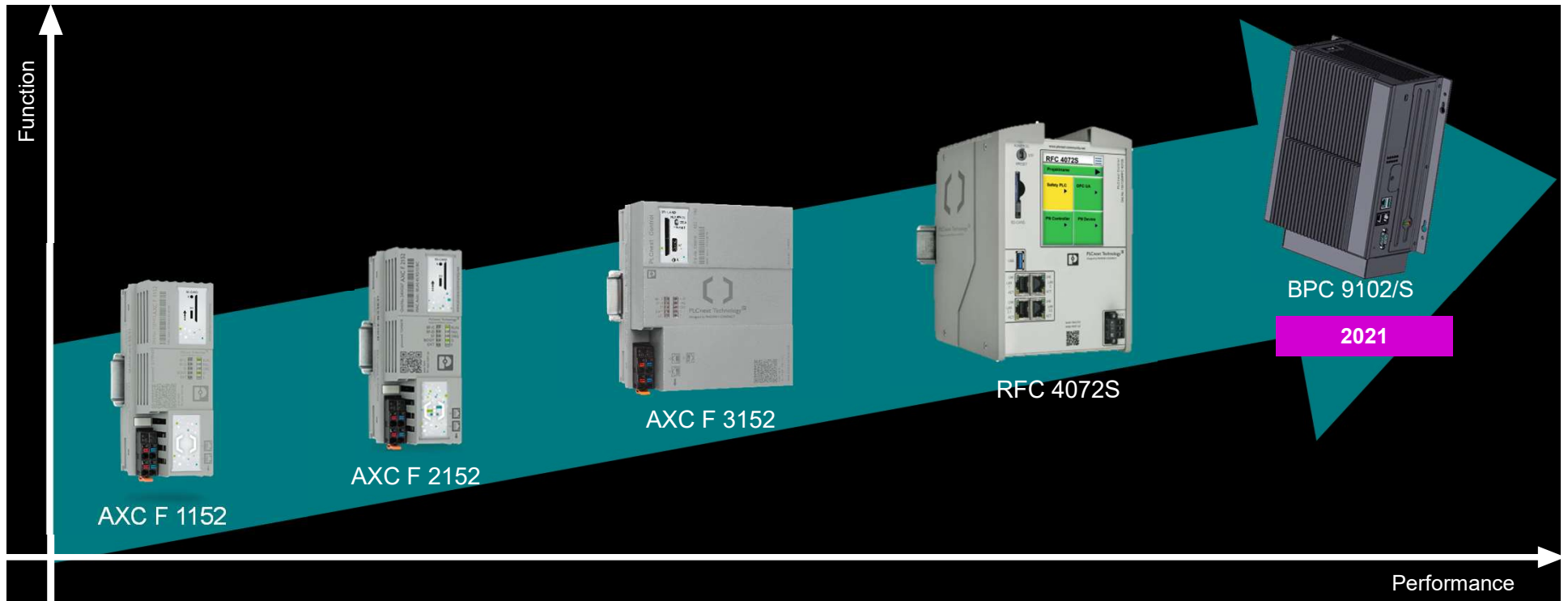

PLCnext Control

PLCnext Technology 
Designed by PHOENIX CONTACT

PLCnext Control for flexible automation with modular hardware platform

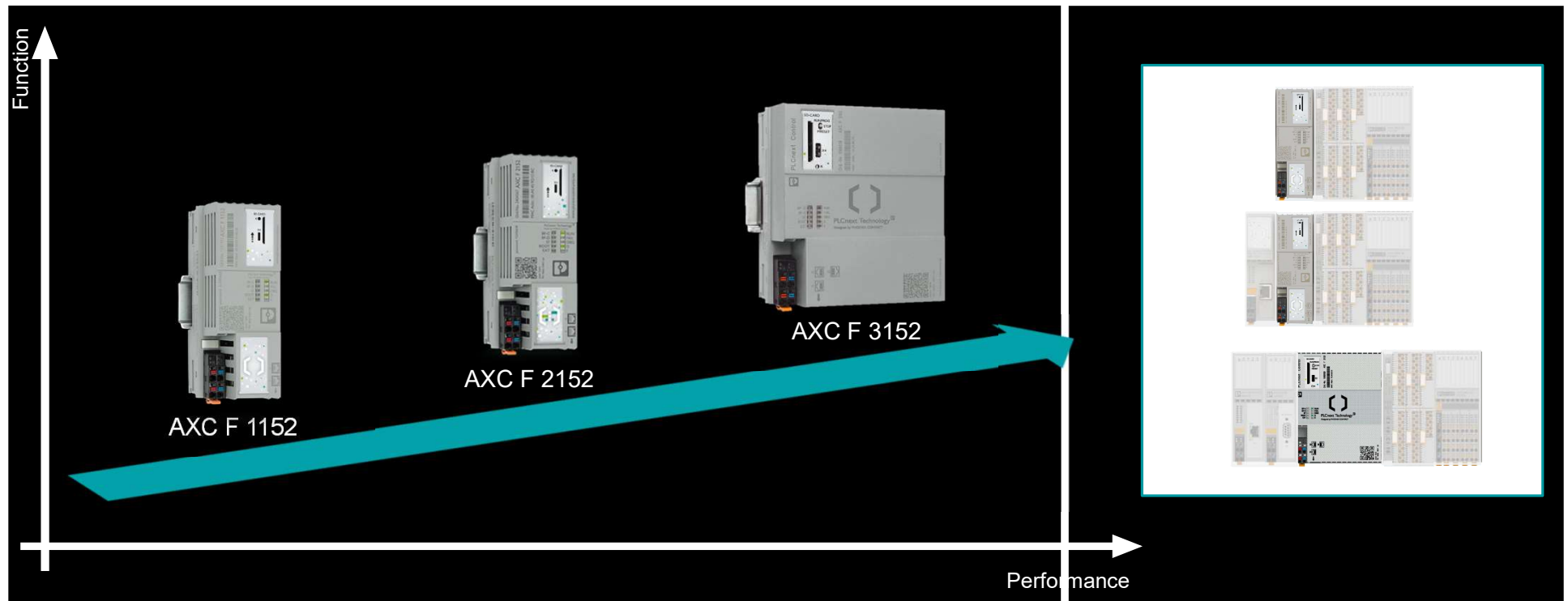

PLCnext Control for centralized applications with decentralized IOs

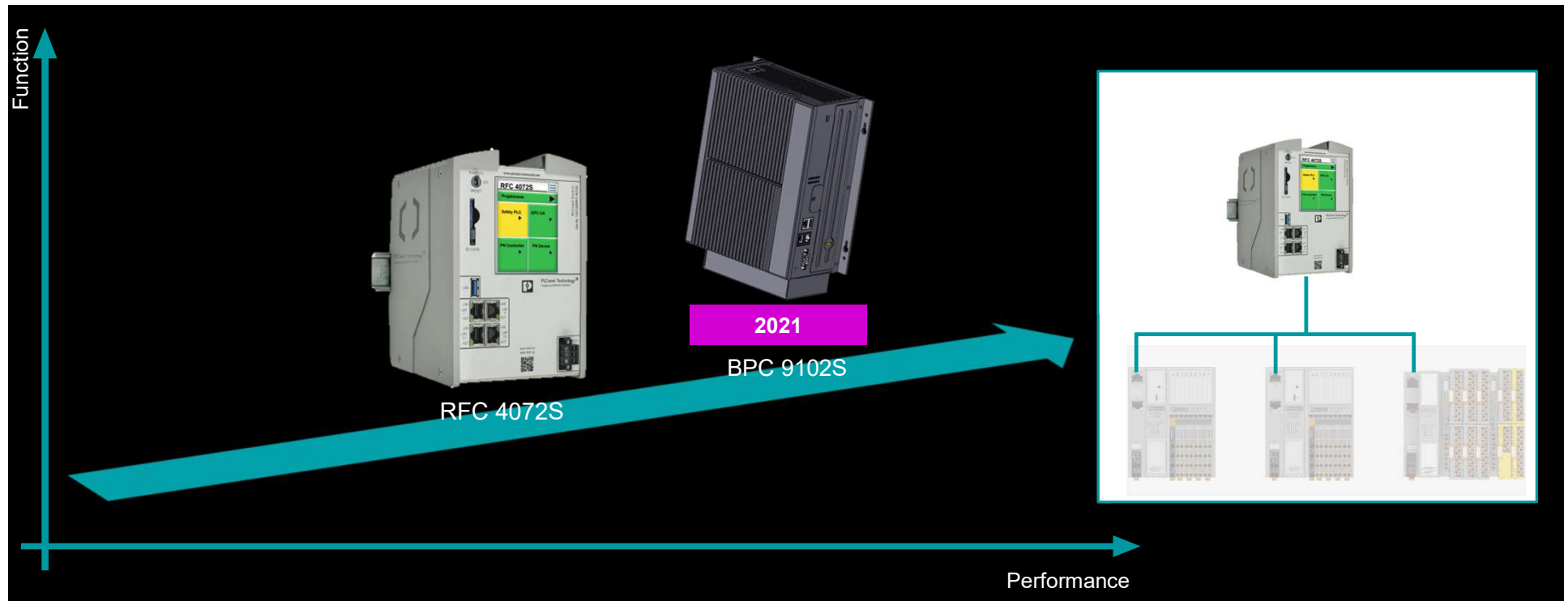

PLCnext Control

PLCnext Technology 
Designed by PHOENIX CONTACT

PLCnext Control for Edge Computing

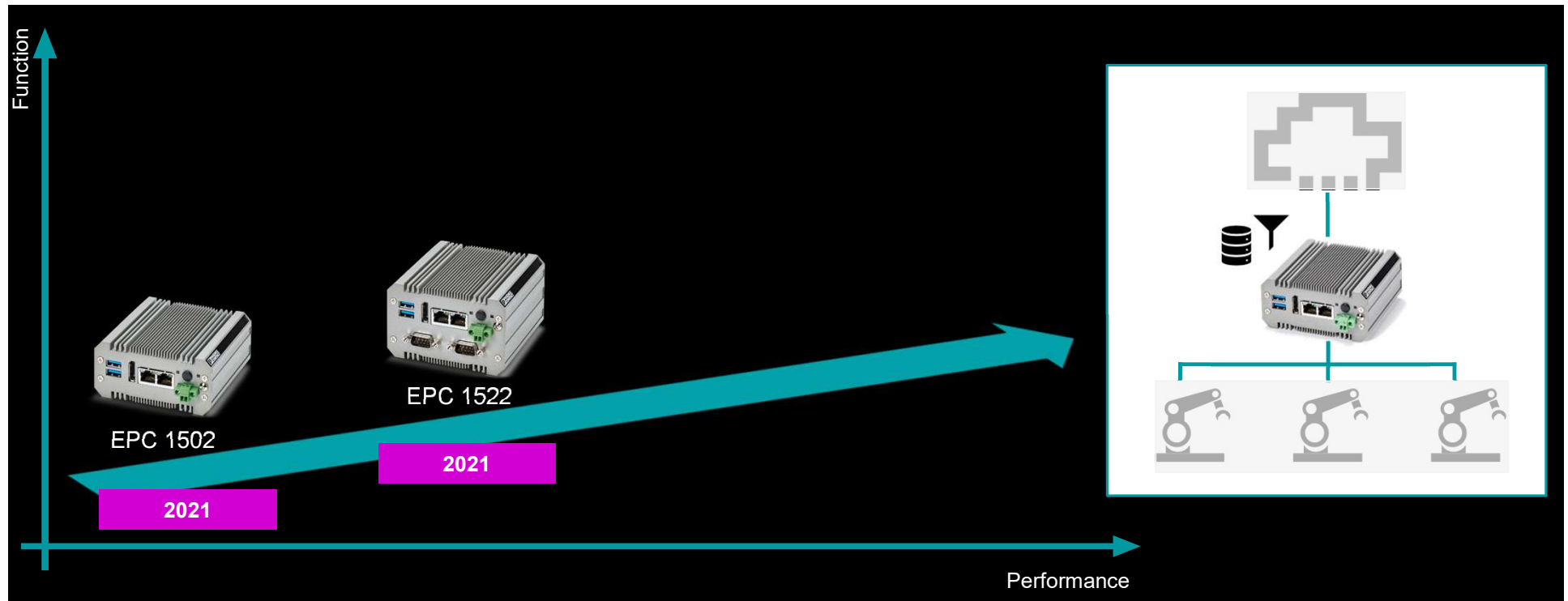

PLCnext Control for intelligent applications with Artificial Intelligence

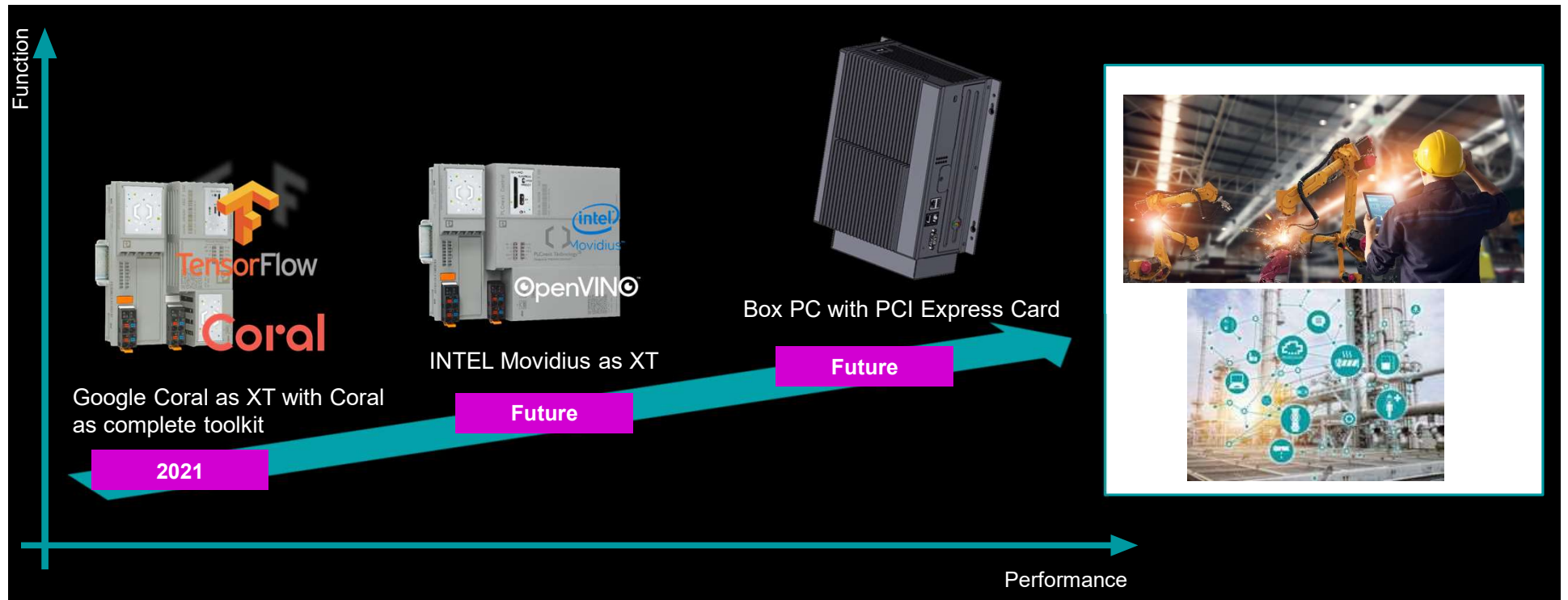



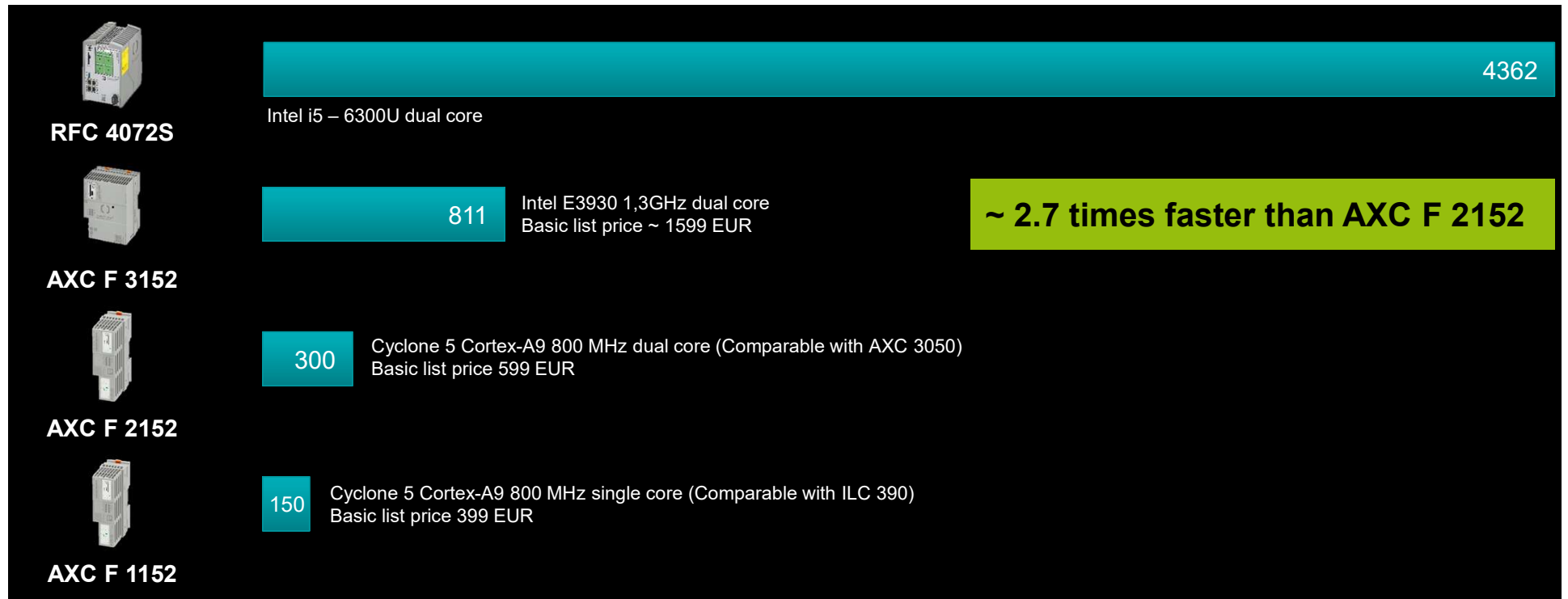



PLCnext Controls Performance Benchmark



PLCnext Control

PLCnext Control AXC F 1152



Core	Working memory	Temperature
 ARM Cortex-A9 (800 MHz)	 512 Mbytes RAM	 -25°C-60°C
 # control tasks (IEC 61131) 8	 Min. cycle time (IEC 61131) 5 ms	 Security TPM integrated

PLCnext Control

PLCnext Technology 
Designed by PHOENIX CONTACT

Entry Level – PLCnext Control AXC F 1152

- Cyclone 5 with ARM Cortex-A9 CPU 1 x 800 MHz
- Number Control-Tasks (IEC 61131): 8
- Min. cycle time (IEC 61131): 5 ms
- Profinet Controller & Device with 16 ARs
- 512 Mbytes RAM
- SD Flash card slot
- 1 x ETH-MAC interface (2 x 10/100 Mbit) switched
- Real-time clock
- Supports INLINE and AXIOLINE I/O modules
- Trusted platform module (TPM) for security
- Temperature range: -25°C up to +60°C



Feature Set Differences – AXC F 1152 vs. AXC F 2152







Feature	AXC F 1152	AXC F 2152
CPU	Cyclone 5 with ARM Cortex-A9 1 x 800 MHz	Cyclone 5 with ARM Cortex-A9 2 x 800 MHz
Approvals	UL, CE	UL, CE, Marine, ATEX
Max. number of control tasks	8 (1 x 8)	32 (2 x 16)
PLCnext extension support (left-hand side)	No	Yes
PROFINET Features	Controller & Device with max. 16 ARs	Controller & Device with max. 64 ARs
Min. task cycle time	5 ms	1 ms

PLCnext Control

PLCnext Control AXC F 2152



The image shows the PLCnext Control AXC F 2152 device, a compact industrial PLC. It features a grey metal casing with a front panel containing an SD-card slot, a QR code, and several status LEDs labeled RUN, FAIL, DBG, D, and E. The top of the device has a barcode and technical specifications including 'Core No. 2404267 AXC F 2152' and 'MAC Addr: 02:80:45:50:13:BC'. The website 'www.plcnext.com/community/print' is also visible.

Core	Working memory	Temperature
 ARM Cortex-A9 (2x 800 MHz)	 512 Mbytes RAM	 -25°C-60°C
 # control tasks (IEC 61131) 32	 Min. cycle time (IEC 61131) 1 ms	 Security TPM integrated

PLCnext Control

PLCnext Technology 
Designed by PHOENIX CONTACT

Proven Standard – PLCnext Control AXC F 2152

- Cyclone 5 with ARM Cortex-A9 CPU 2 x 800 MHz
- 512 Mbytes RAM
- SD Flash card slot
- 1 x ETH-MAC interface (2 x 10/100 Mbit) switched
- Micro-USB type C
- Real-time clock
- Supports INLINE and AXIOLINE I/O modules
- Left side extension capability
- Trusted platform module (TPM) for security
- Temperature range: -25°C up to +60°C









PLCnext Control

PLCnext Control AXC F 3152



The image shows a grey PLCnext Control AXC F 3152 PLC unit. It features a front panel with a terminal block, a display, and various status indicators. The unit is labeled with 'PLCnext Control' and 'PLCnext Technology'.

Core	Working memory	Temperature
 Intel ATOM x5-E3930 dual-core	 2 GB DDR4 dual-channel RAM	 -25°C-60°C
# control tasks (IEC 61131)  32	Min. cycle time (IEC 61131)  500 µs	Security  TPM integrated

More Performance – PLCnext Control AXC F 3152

- Intel ATOM x5-E3930 dual-core CPU (2 x 1,3 GHz)
- 2 GB DDR4 dual-channel RAM
- 3 independent ETH-MAC interfaces (3 x 1 Gbit)
- Supports 2 PLCnext Control extensions (internal PCIe bridge)
- Supports INLINE and AXIOLINE I/O modules
- Integrated uninterruptible power supply (UPS) for targeted application shutdown
- SD card slot
- Diagnostic LEDs
- Real-time clock
- Temperature range: -25°C up to 60°C
 - Optional fan to increase service life









PLCnext Control

PLCnext Control RFC 4072S



The image shows the rear panel of the PLCnext Control RFC 4072S. It features a central display with a green and yellow interface showing 'Safety PLC' and 'OPC UA'. Below the display are two RJ45 ports labeled 'LAN 1' and 'LAN 2'. To the left, there are 'USB' and 'SD-CARD' ports. The top left has 'POWER' and 'RESET' buttons. The bottom right has a 'PWR' button and a 'PWR' indicator. The device is labeled 'PLCnext Technology' and 'RFC 4072S'.

Core	Working memory	Temperature
 Intel i5 6300U 2 x 2,4 GHz processor # control tasks (IEC 61131)  32	 4 GB DDR 4 dual channel RAM Min. cycle time (IEC 61131)  500 µs	 0°C up to 55°C with fan Security  TPM integrated

PLCnext Control

PLCnext Control RFC 4072S

- Intel i5 6300U 2 x 2,4 GHz processor
- 4 GB DDR 4 dual channel RAM
- Profisafe integrated (up to 300 F-Devices)
- Operation Mode Switch
- Touch display
- SD Flash card slot
- 3 ETH-MAC interfaces (2 x 1 Gbit, 1 x 100 Mbit switched)
- Real-time clock
- Trusted platform module (TPM) for security
- Temperature range: 0°C up to 55°C with fan





PLCnext Technology 
Designed by PHOENIX CONTACT



PLCnext Control

PLCnext Control BPC 9102S

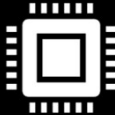

<p>Core</p>  <p>Intel i7 CPU 8 cores</p>	<p>Random access memory</p>  <p>2GB RAM (min), int. UPS</p>	<p>Temperature</p>  <p>-20°C-60°C</p>
<p>Storage</p>  <p>Removable mass storage</p>	<p>Connections</p>  <p>2x RJ45, 1x TSN, 1x USB</p>	<p>PCIe</p>  <p>Safety board, AI acceleration</p>

PLCnext Control

PLCnext Control BPC 9102S

PLCnext Technology 
Designed by PHOENIX CONTACT

- CPU: i7-10700TE (10th Gen 8-Core)
- RAM: 16GB
- Interfaces:
- 3 separate and independent Ethernet interfaces with 1 RJ45 port each
 - LAN1: PN Controller (I225), 1GBit
 - LAN2: PN Device (I225), 1GBit
 - LAN3: RAW user ethernet communication (I225), 1GBit
- 1 Serial Interface RS232
- 1 USB for FW/SW Update
- Reset button and power switch
- SD Card
- Internal Super-cap UPS module
- Fan (only on between 50-60°C) to expand MTBF



PLCnext Technology – New Starterkit

PLCnext Technology 
Designed by PHOENIX CONTACT

Start now and become a part of PLCnext Technology



PLCnext Technology 
Designed by PHOENIX CONTACT
Ecosystem for limitless automation

GETTING STARTED
starterkit.plcnextcommunity.com

Getting started 

Online 

Hardware 

PLCnext Control & Axioline Smart Element

starterkit.plcnextcommunity.com



What else is worth mentioning ...

New Starterkit, new sales channels



Hardware



**PLCnext Control AXC
F 2152 + Axioline
Smart Elements**

3rd Party Distribution/
Channel Partner



**RS Components,
RealPars**

Getting started



Online

Extension



**Additional space
on DIN rail**



Marketing Material

starterkit.plcnextcommunity.com



Countless possibilities in hardware variance

PLCnext Control

PLCnext Technology ¹²
Designed by PHOENIX CONTACT

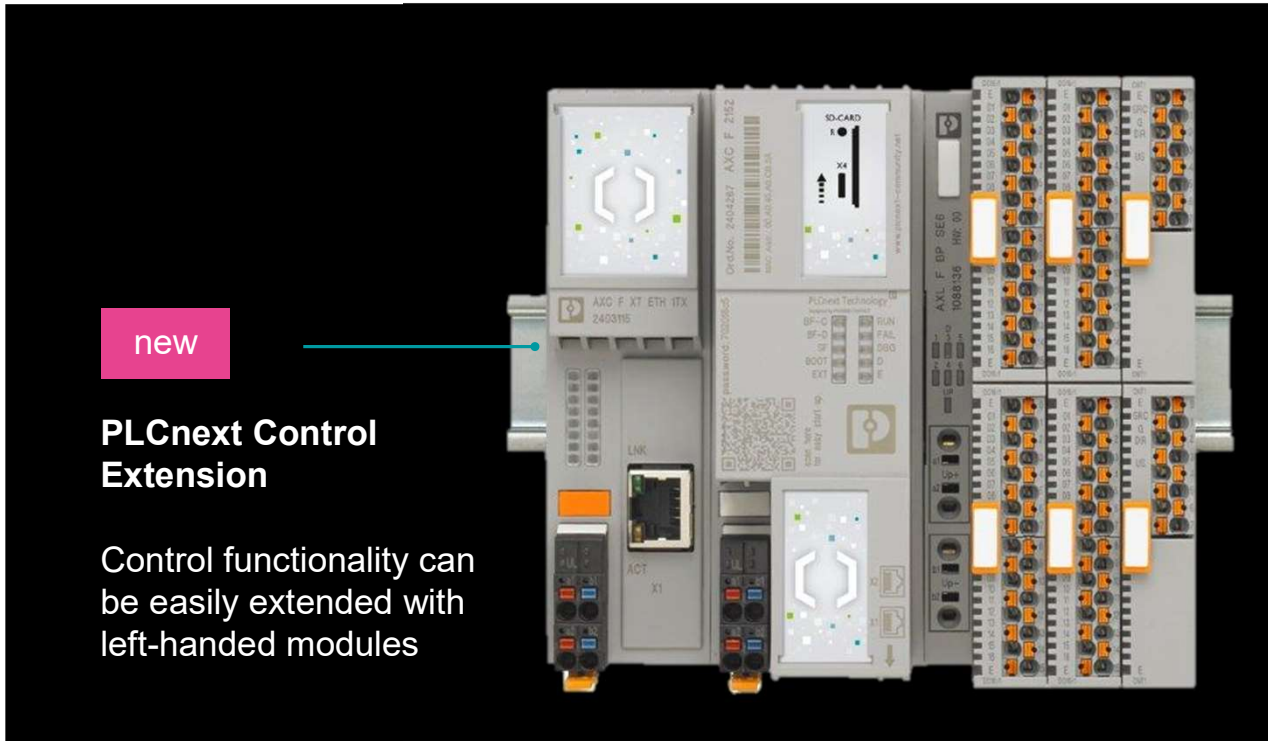

new

PLCnext Control Extension

Control functionality can be easily extended with left-handed modules

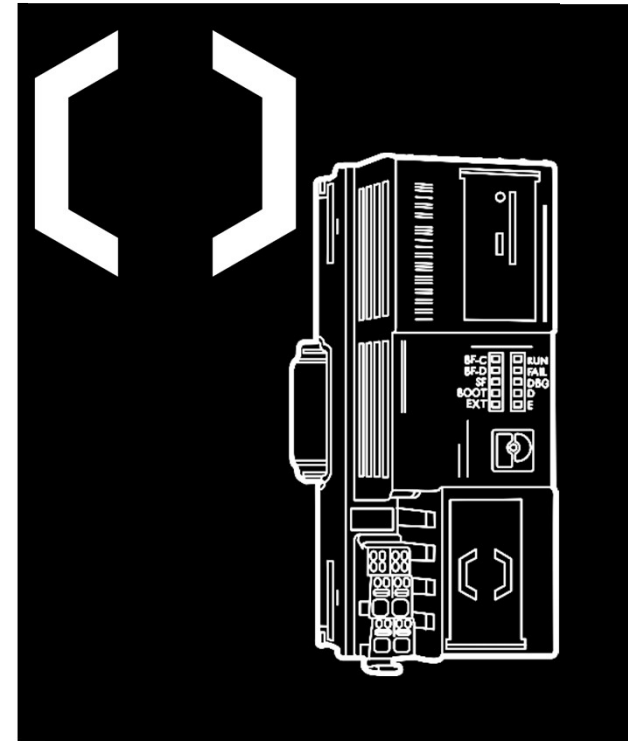

PLCnext Ecosystem – PLCnext Control

Left-hand side extension possibilities

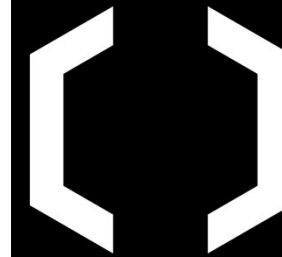
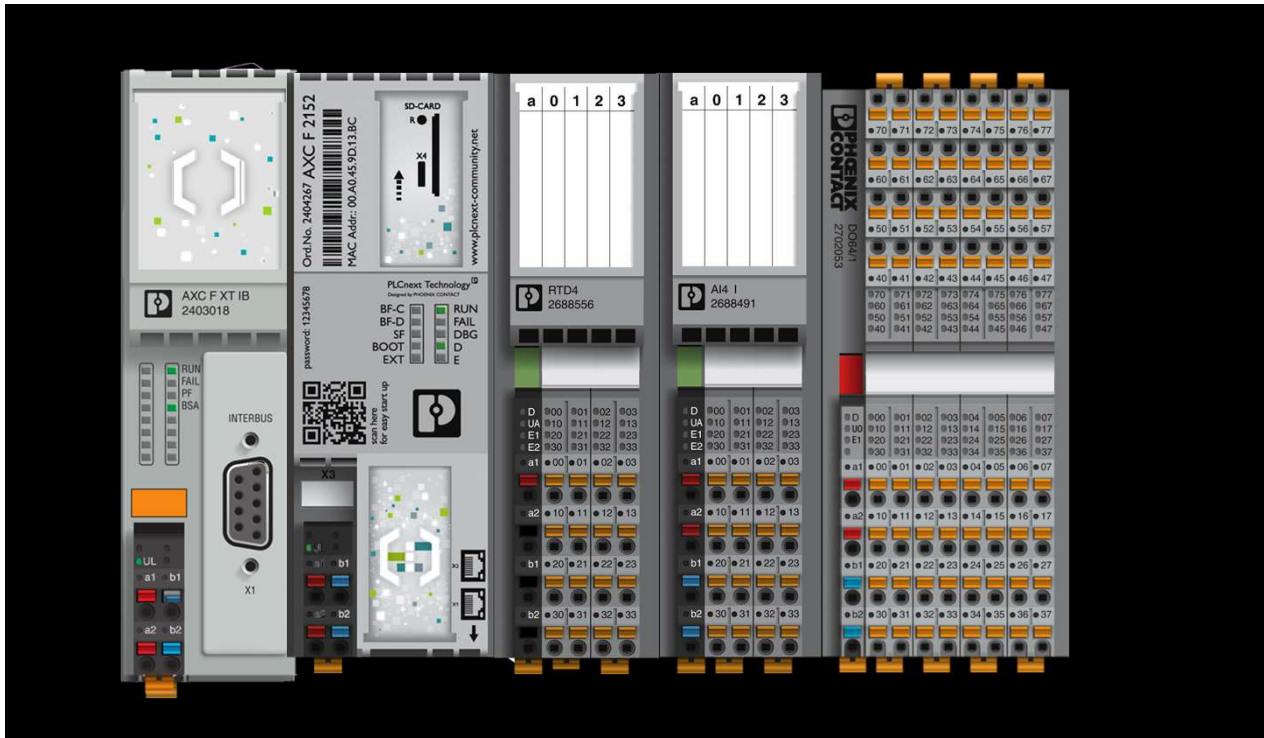

- Modular expandability of the controller through left-sided expansion modules on the PCI express interface via a corresponding bus socket
- Unlimited expansion possibilities

PLCnext Ecosystem – PLCnext Control

Portfolio PLCnext Control Extensions

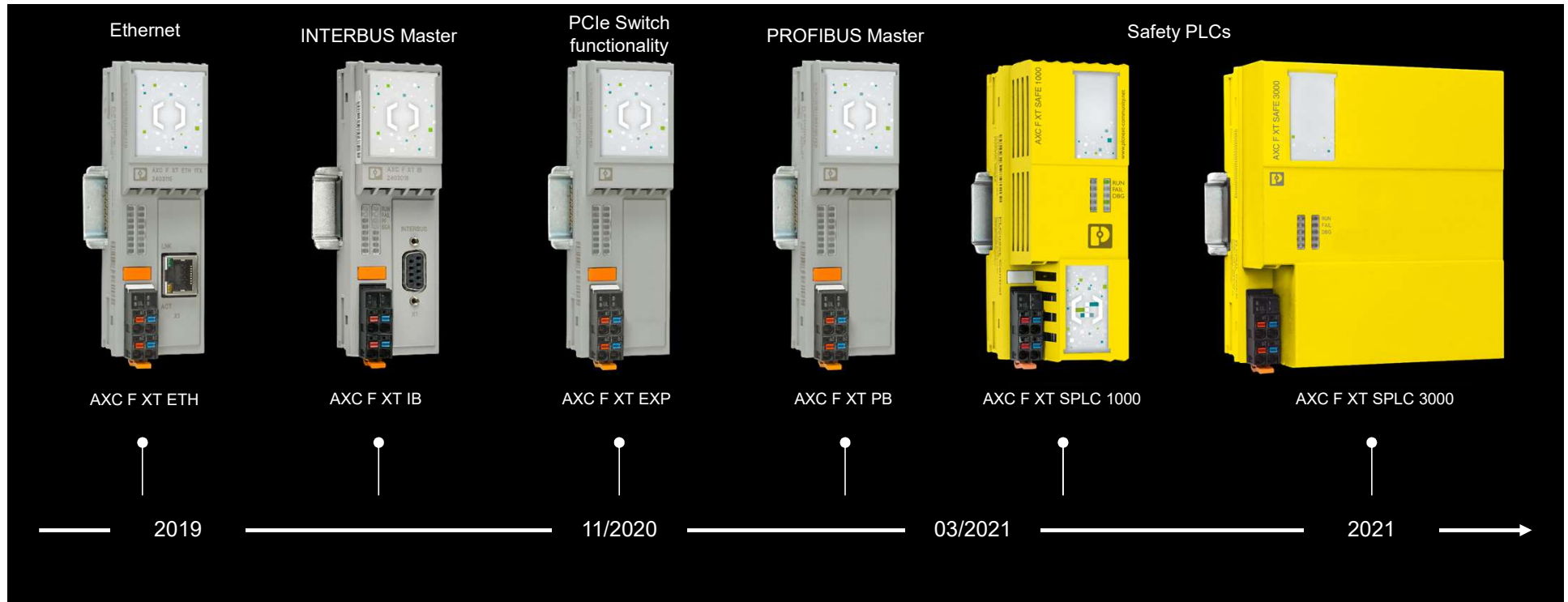

PLCnext Control

PLCnext Extension AXC F XT ETH



- Additional 1Gbit MAC interface
- Temperature range: -25°C up to 60°C
- Profinet Control capability
- Security due to separated interfaces
- Modularity and Flexibility
- Approvals
- UL (Hazloc), CUL
- DNV/GL, LR, BV, ABS, ...
- IEC Ex, ATEX

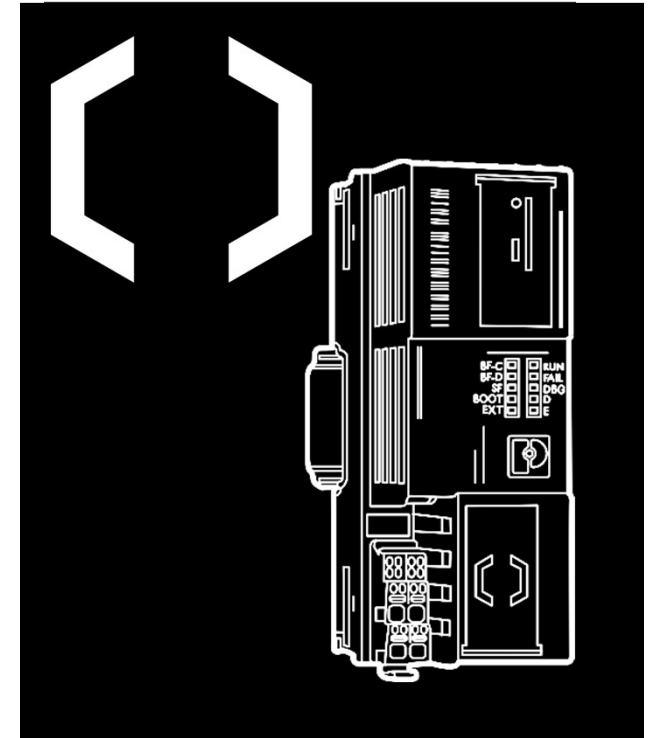

PLCnext Control

PLCnext Extension AXC F XT IB

PLCnext Technology 
Designed by PHOENIX CONTACT



- Additional INTERBUS Master
- Up to 512 Devices, up to 255 Remote Devices
- Up to 126 PCP Devices
- Up to 16 Remote Bus Level
- 4096 Bit Process data
- 500kBit und 2 Mbit
- Ideal for Retrofit applications
- Approvals
 - UL (Hazloc), CUL, IEC Ex, ATEX
 - DNV/GL, LR, BV, ABS, ...
- Temperature range: -25°C up to 60°C

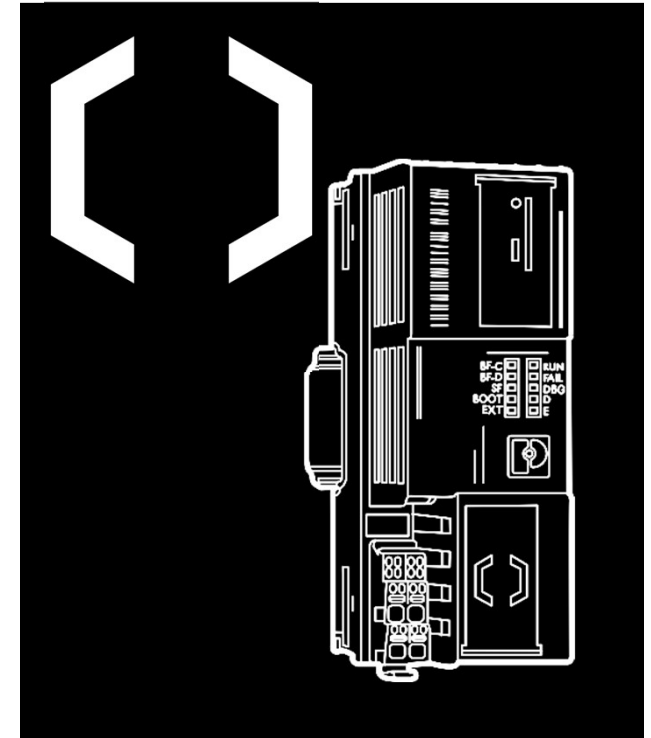

PLCnext Technology 
Designed by PHOENIX CONTACT

PLCnext Control for Edge Computing

Edge Computing

- Cloud computing has revolutionized how people store and use their data, but...
- Latency, bandwidth, security or a lack of offline access can be problematic
- To solve this problem, users need robust, secure and intelligent on-premise infrastructure for edge computing
- When data is physically located closer to the user who connect to it, information can be shared quickly, securely and without latency

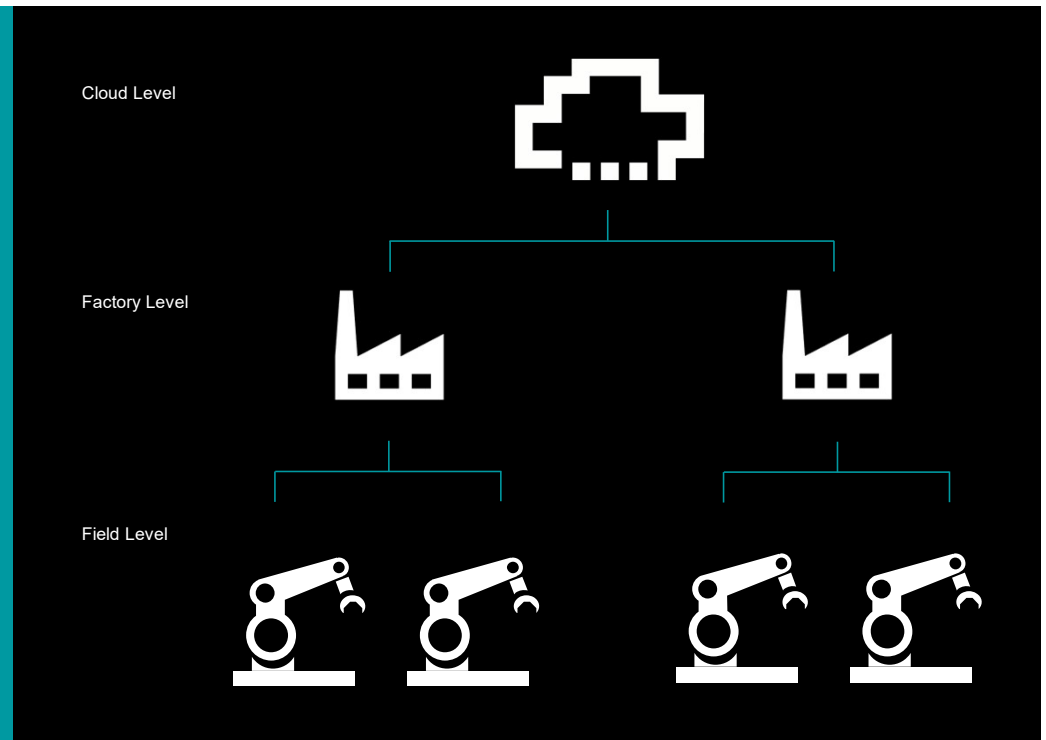

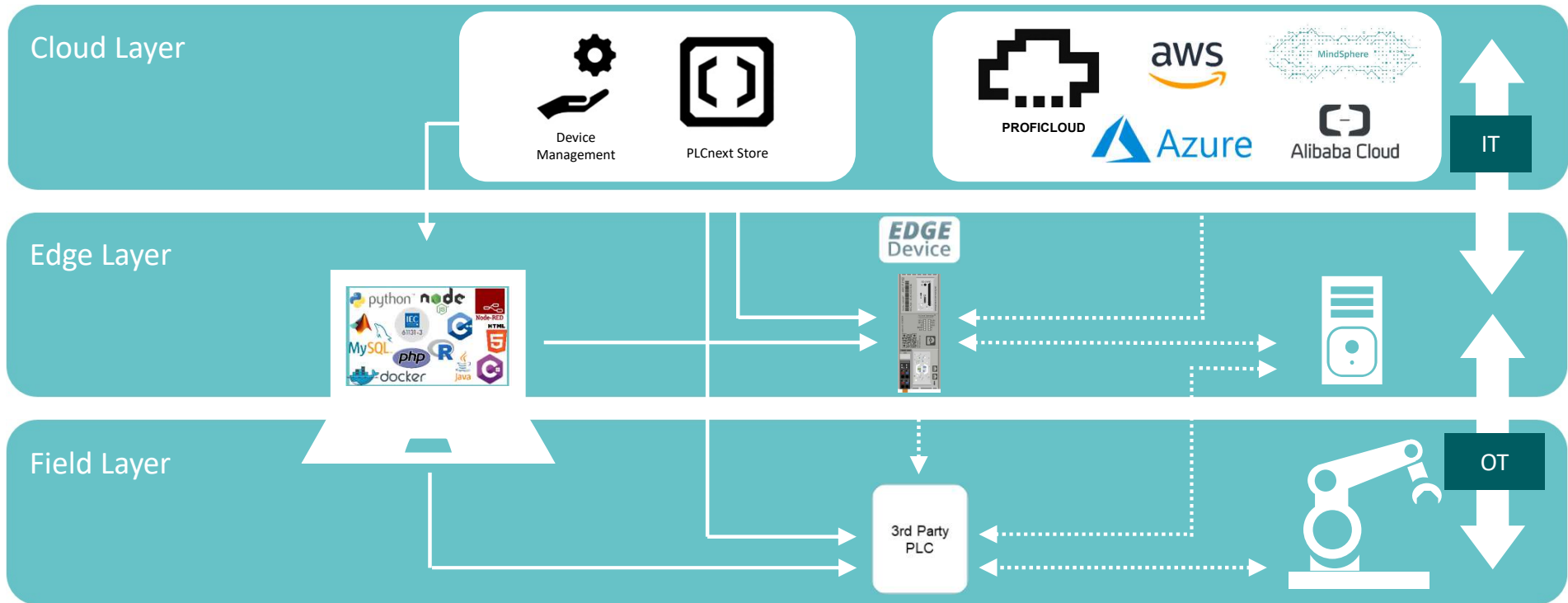

PLCnext Control

7
1

Definition

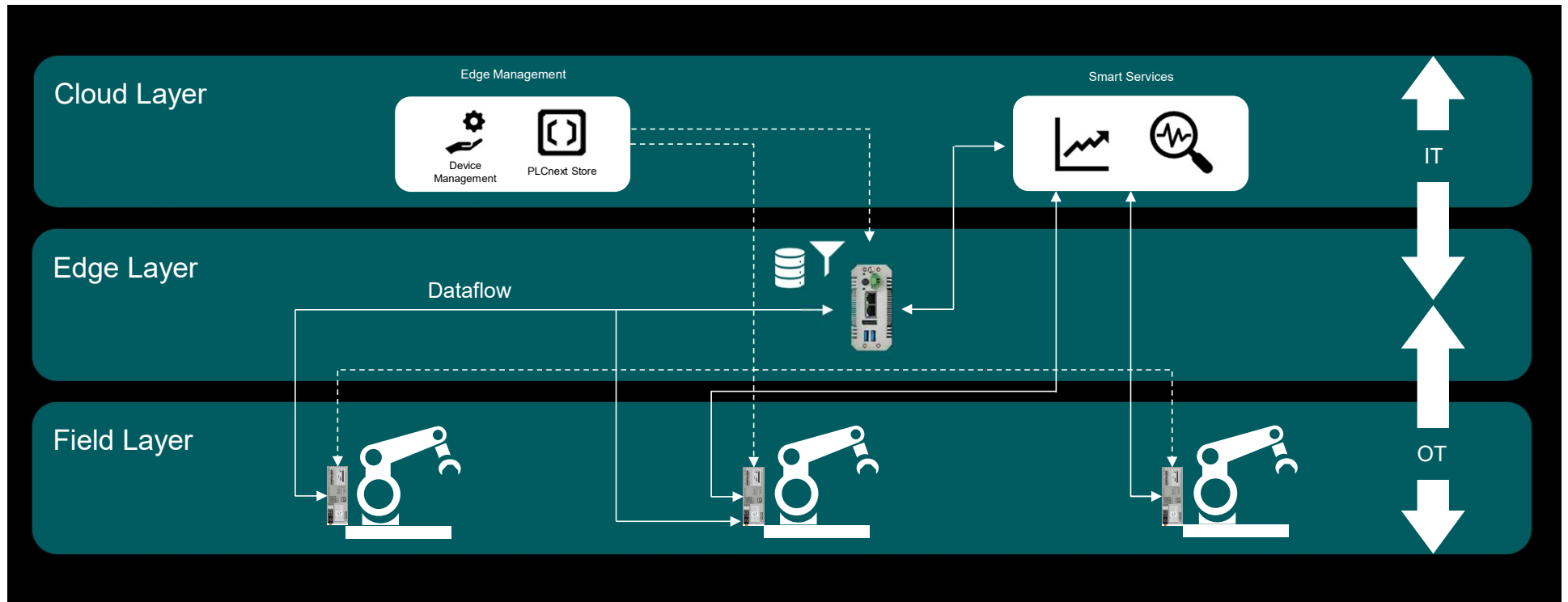



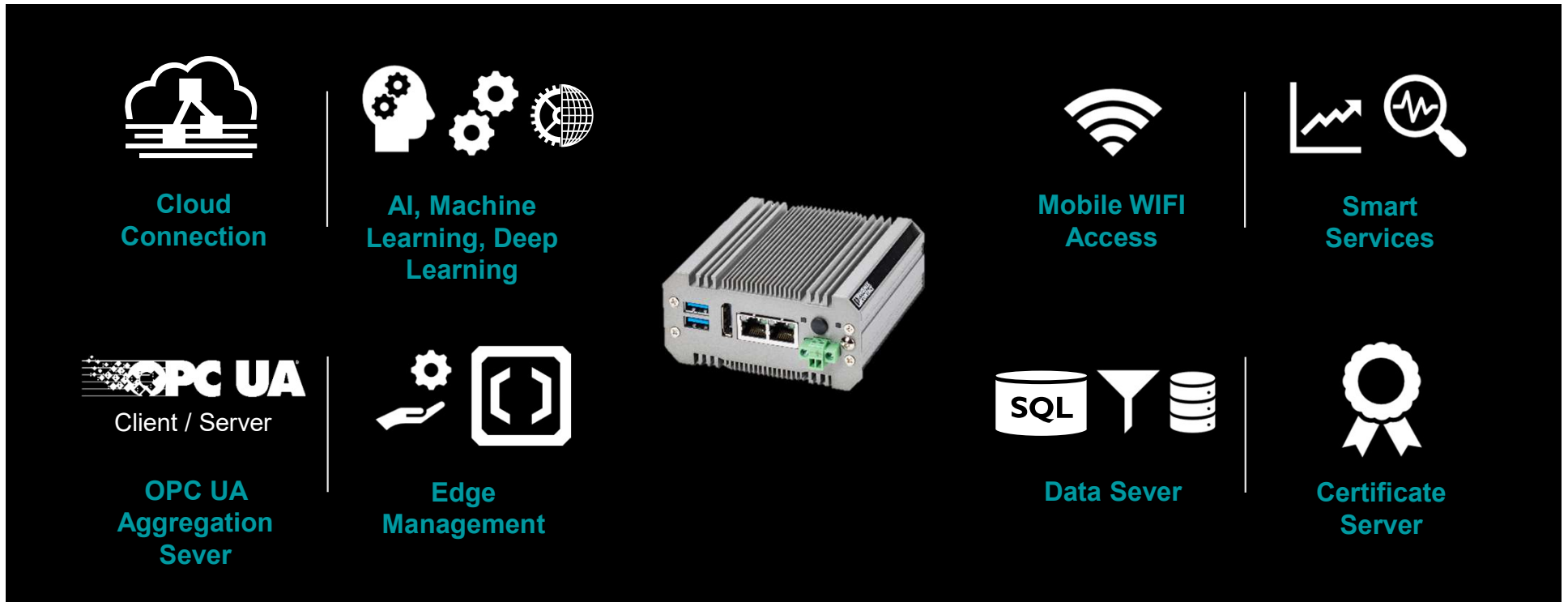



Edge functions within PLCnext Control



PLCnext Control

PLCnext Control for Edge Computing EPC 1502



<p>Core</p>  <p>Intel Celeron N3350 (Dual Core)</p>	<p>Random access memory</p>  <p>2 GB RAM</p>	<p>Temperature</p>  <p>0°C-50°C</p>
<p>Storage</p>  <p>32 GB eMMC</p>	<p>Approvals</p>  <p>UL, CE</p>	<p>Wifi</p>  <p>Integrated</p>

PLCnext Control

PLCnext Control for Edge Computing EPC 1522



Core



Intel Celeron
N3350 (Dual Core)

Random access memory



4 GB RAM

Temperature



0°C-50°C

Storage



32 GB eMMC +
128 GB m.2 SSD

Approvals



UL, CE

Wifi



Integrated

Edge Computing

Artificial intelligence

Google Coral as XT with
Coral as complete toolkit



INTEL Movidius as XT



Box PC with PCI Express Card



Edge Computing

Artificial intelligence - AXC F XT ML 1000



Join and get involved

PLCnext Community

PLCnext Technology 
Designed by PHOENIX CONTACT

More about PLCnext Technology



plcnextcommunity.com

Upload or download apps



plcnextstore.com

Ask a question in the forum



phoe.co/PLCnextForum

Use or share open source code



github.com/plcnext

Get in touch on LinkedIn



phoe.co/PLCnextLinkedIn

#PLCnext
#IamPLCnext



PLCnext Community

Join and get involved
#IamPLCnext

PLCnext & Axioline Smart Elements

Modular automation system

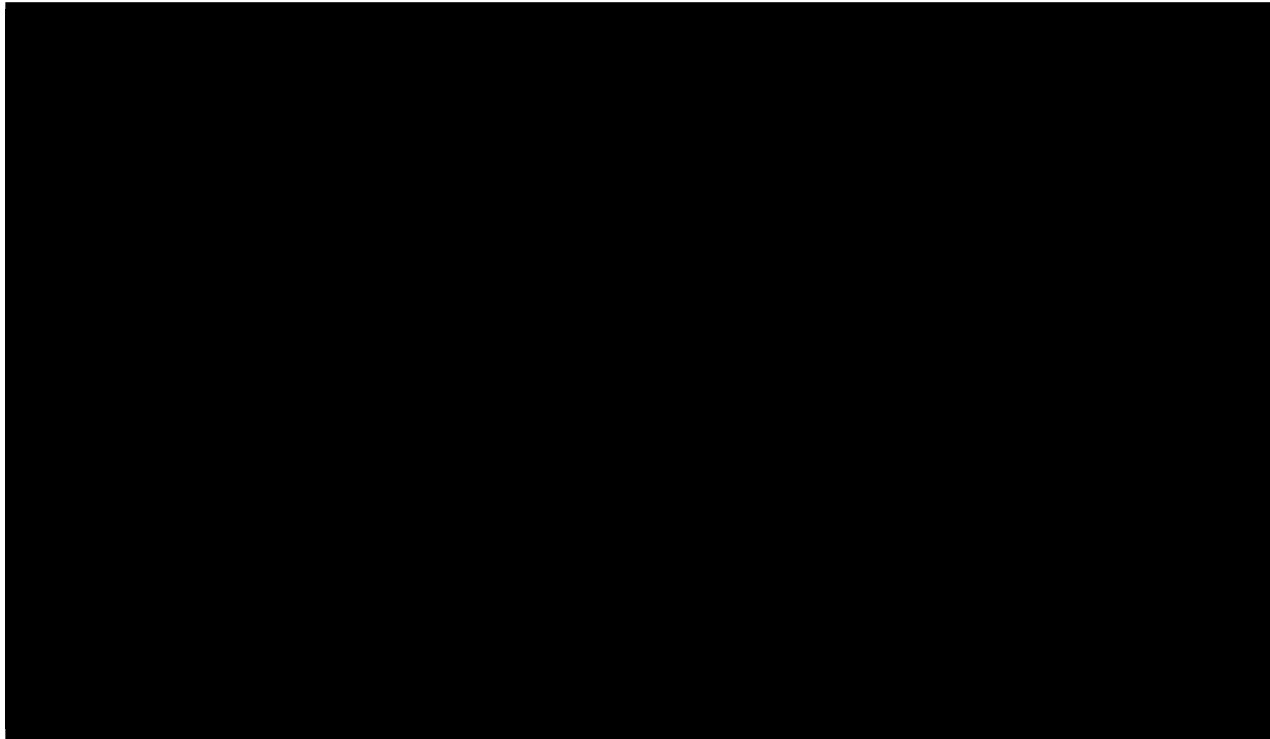

- Scalable automation system for simple to complex assignments
- Large selection of modules according to the modular system principle
- Optimal complement to PLCnext Control
- All components are part of the COMPLETE line system

PLCnext Technology [®]
Designed by PHOENIX CONTACT

COMPLETE line

What else is worth mentioning ...

Visitors can experience PLCnext: We live and think digitalization

PLCnext Factory –
 PLCnext Technology becomes a tangible experience

VISION:

In a rapidly changing world, we have to rethink our production processes every day. Digitalization is the key to this. Every day, we move borders, are flexible and open to new ways of working together. So are our products.



Tour for visitors with 5 stations on digitization topics

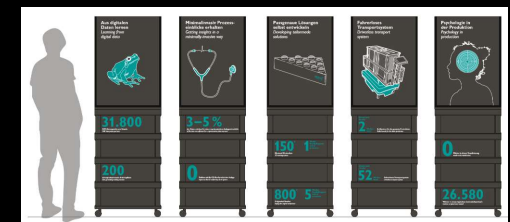

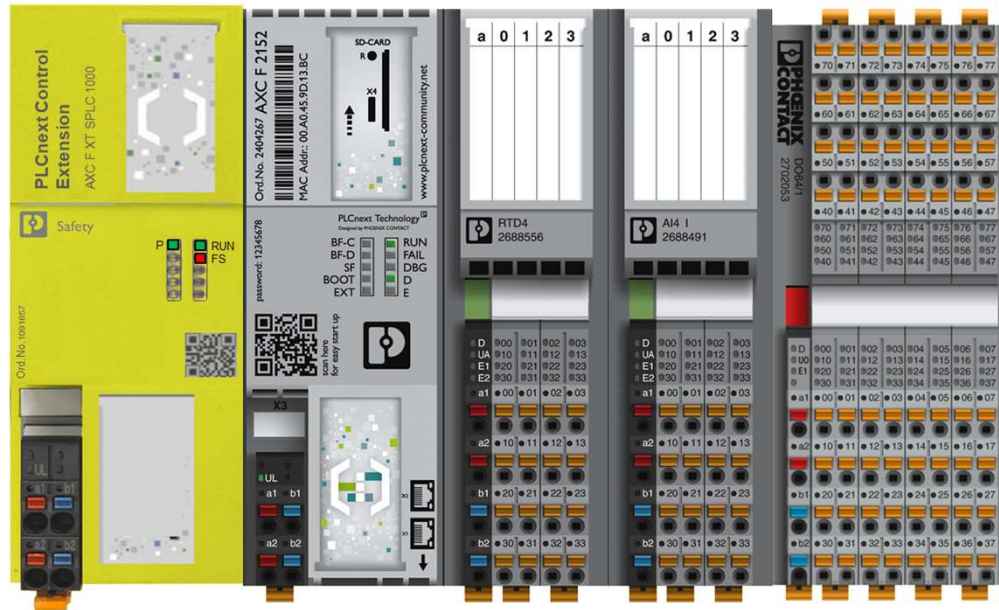

Controladores de Seguridad

PLCnext Control

PLCnext Extension AXC F XT SPLC 1000

PLCnext Technology 
Designed by PHOENIX CONTACT

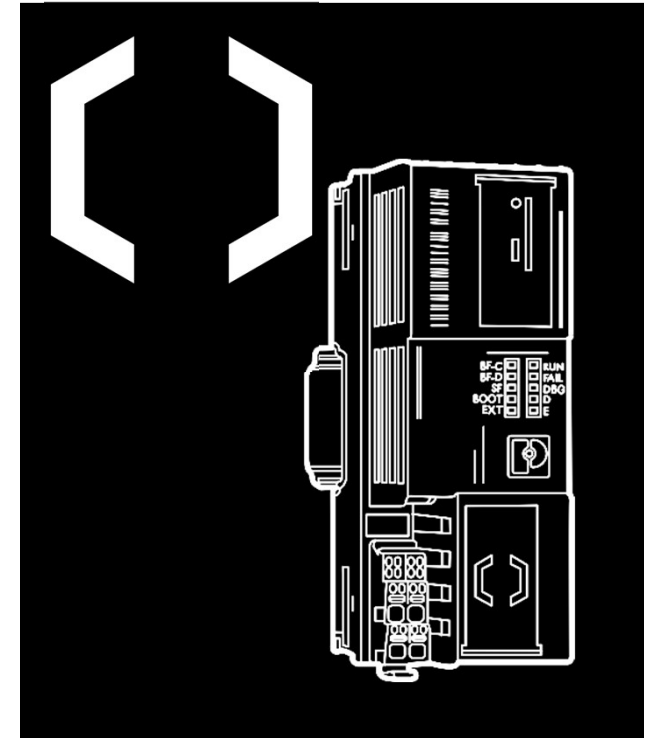
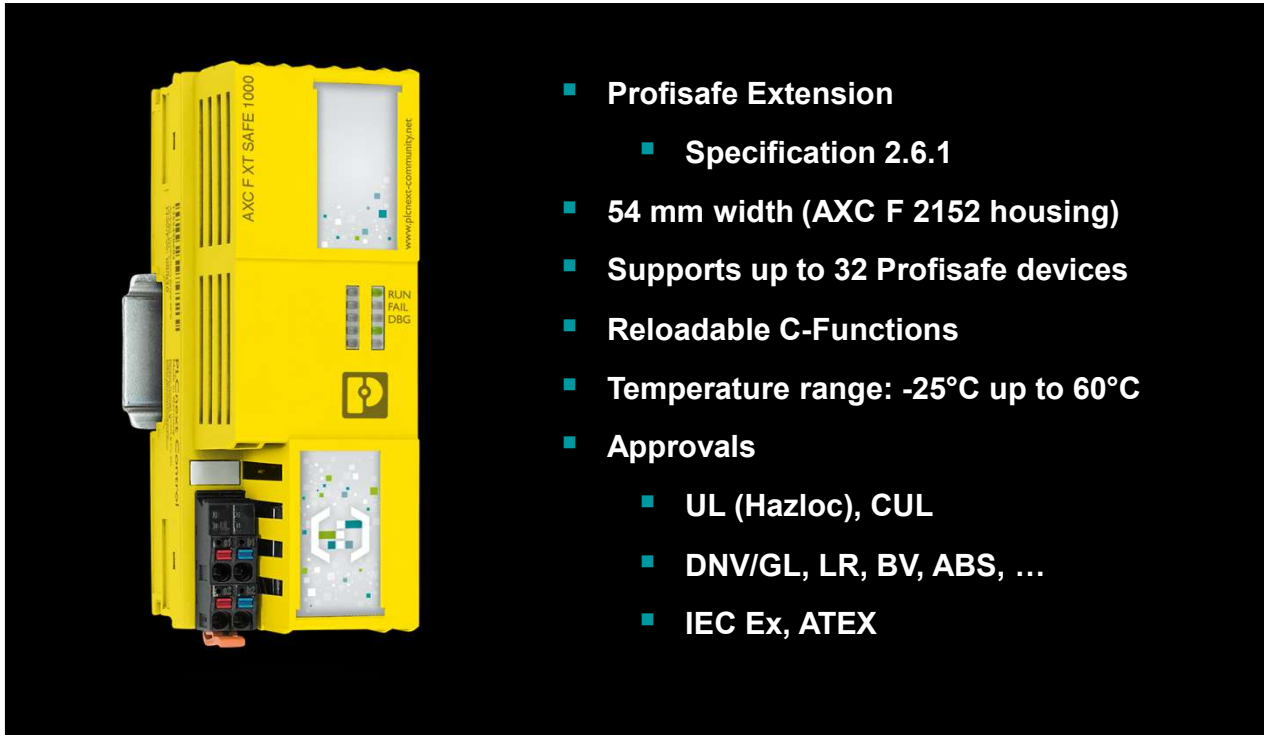

PLCnext Control

PLCnext Extension AXC F XT SPLC 3000

PLCnext Technology 
Designed by PHOENIX CONTACT

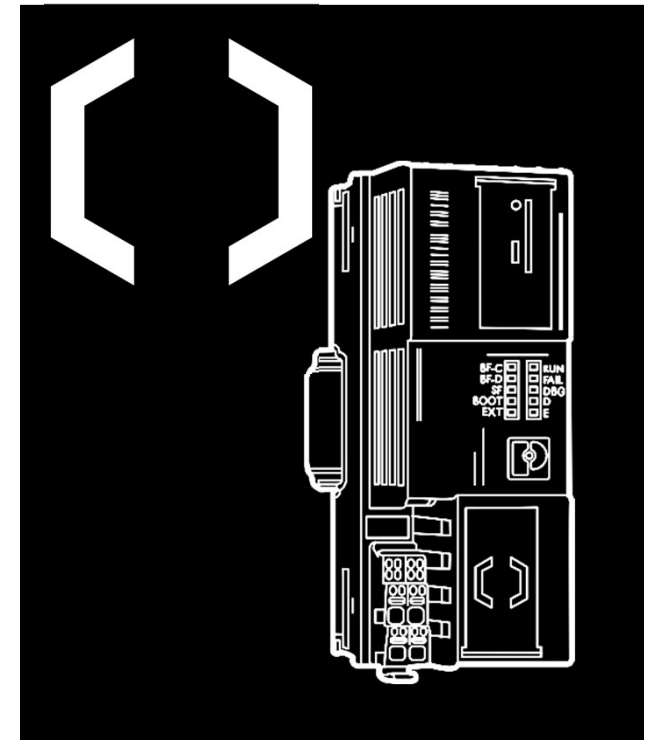

PLCnext Ecosystem – PLCnext Control - IO

Axioline Smart Elements

The diagram illustrates the Axioline Smart Elements ecosystem. On the left, a rack of PLCnext Control modules is shown, with three Axioline modules highlighted in orange. Three teal arrows point from these modules to the right, each labeled with a feature: 'COMPACT', 'FLEXIBLE', and 'MODULAR'. The 'COMPACT' arrow points to a hand holding a small 16-channel module, with the text '16 channels on 15 mm width' next to it. The 'FLEXIBLE' arrow points to a stack of three modules, with the text 'Pluggable as needed' next to it. The 'MODULAR' arrow points to a series of three modules connected in a chain. On the right side of the diagram, there is a text block: 'Combinable with all PLCs of the Axioline family, with PLCnext Control, Bus couplers and Axioline F I/O-modules'. At the bottom right, the Phoenix Contact logo is displayed with the tagline 'INSPIRING INNOVATIONS'.

COMPACT → 16 channels on 15 mm width

FLEXIBLE → Pluggable as needed

MODULAR

Combinable with all PLCs of the Axioline family, with PLCnext Control, Bus couplers and Axioline F I/O-modules

PHOENIX CONTACT
INSPIRING INNOVATIONS

Axioline Smart Elements

Automate smart and economically



Ready for automation

All necessary functionalities
incl. Safety and IO-Link

DI

SDI

AI

IO-Link

INC

DO

SDO

AO

RS485

CNT

Axiline Smart Elements

More to come

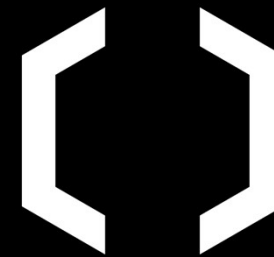
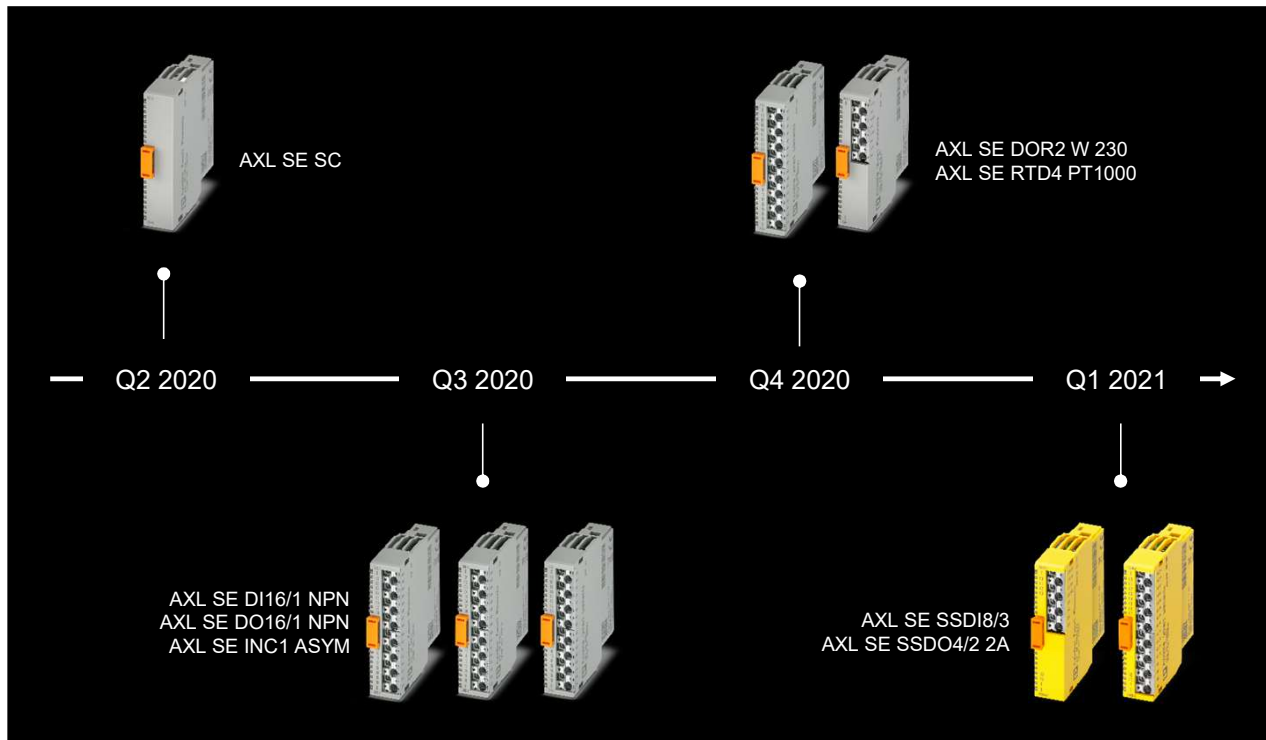

Be always up to date with the [I/O systems & light community](#) at the PC World.

Check regularly for latest information on new products, marketing tools and management updates.

PLCnext Technology

Functional Safety Portfolio with PLCnext Technology

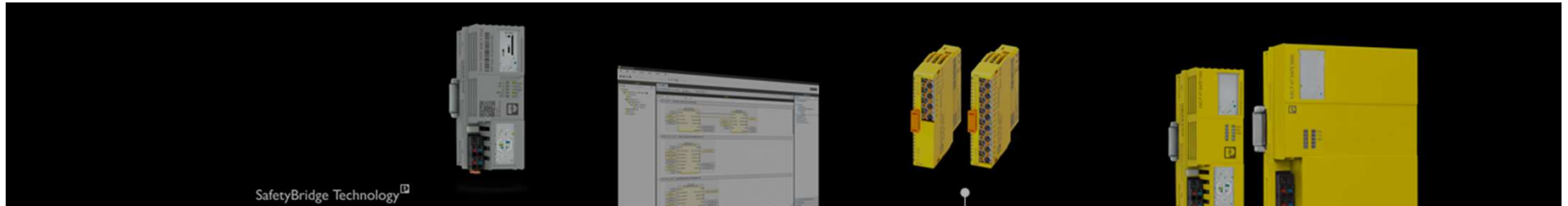

SafetyBridge TechnologyTM

Limitless possibilities for functional safety applications
with PLCnext Technology



PLCnext Technology

Functional Safety

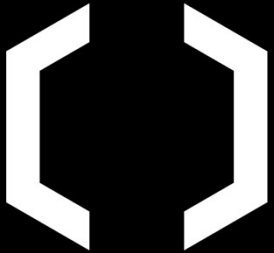

PLCnext Extension AXC F XT SPLC 3000

Core



ARM A8 & A9

of Profisafe devices



300

Temperature



-25°C - 60°C

Width



100mm

Approvals



UL, CUL, etc

C Functions



Reloadable

PLCnext Technology

Functional Safety

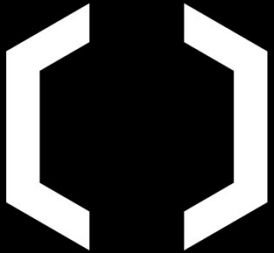

PLCnext Extension AXC F XT SPC 1000

Core



2 x Cortex M4

of Profisafe devices

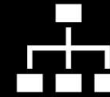

32

Temperature



-25°C - 60°C

Width



45mm

Approvals



UL, CUL, etc

C Functions



Reloadable

PLCnext Technology

PLCnext Control Extension SPLC 1000









AXC F XT SAFE 1000

www.phoenixcontact.com

RUN
PAUSE
STOP

PLCnext Extension AXC F XT SPLC 1000

Core  2 x Cortex M4	# of Profisafe devices  32	Temperature  -25°C - 60°C
Width  45mm	Approvals  UL, CUL, etc	C Functions  Reloadable

PLCnext Technology







PLCnext Control Extension SPLC 3000



AXC F XT SAFE 3000

RUN
FAL
DSD

PLCnext Extension AXC F XT SPLC 3000







 Core ARM A8 & A9	 # of Profisafe devices 300	 Temperature -25°C - 60°C
 Width 100mm	 Approvals UL, CUL, etc	 C Functions Reloadable

PLCnext Control

PLCnext Control RFC 4072S



The image shows a white PLCnext Control RFC 4072S device. It features a color touchscreen display with a green and yellow interface. The screen displays 'RFC 4072S' at the top, followed by 'Programmer', 'Safety PLC', 'DPC I/O', 'FW Controller', and 'FW Device'. Below the screen are several ports, including LAN ports labeled 'LAN 1', 'LAN 2', 'LAN 3', and 'LAN 4'. The device is mounted on a DIN rail.

Core	Working memory	Temperature
 Intel i5 6300U 2 x 2,4 GHz processor	 4 GB DDR 4 dual channel RAM	 0°C up to 55°C with fan
 # control tasks (IEC 61131) 32	 Min. cycle time (IEC 61131) 0,5 ms	 Security TPM integrated

PLCnext Controls

PCIe SPLC 3000

PLCnext Technology 
Designed by PHOENIX CONTACT



**Highest performance for
any automation application**

Functional Safety Integration

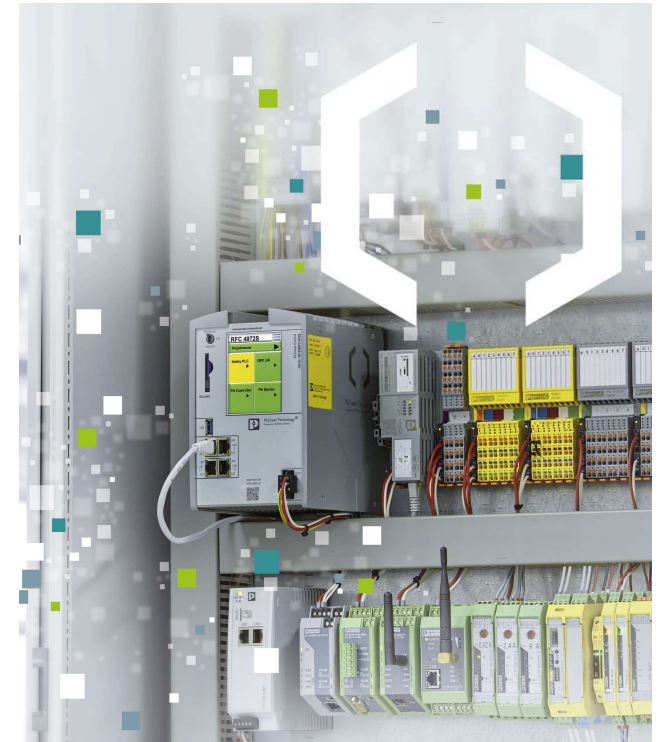
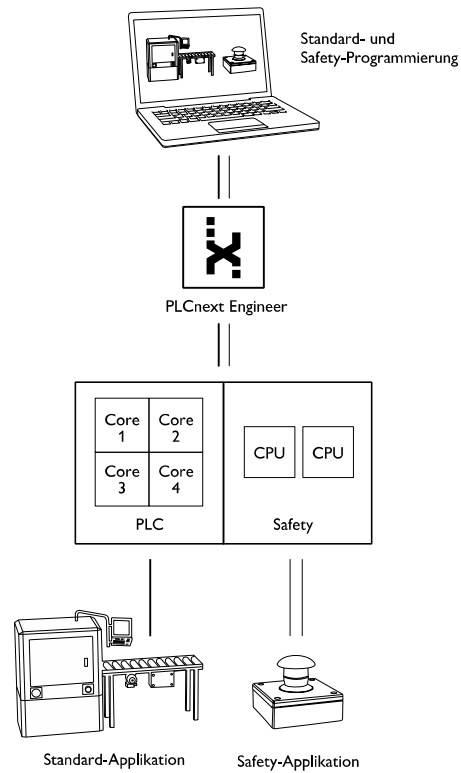

Safety integrated

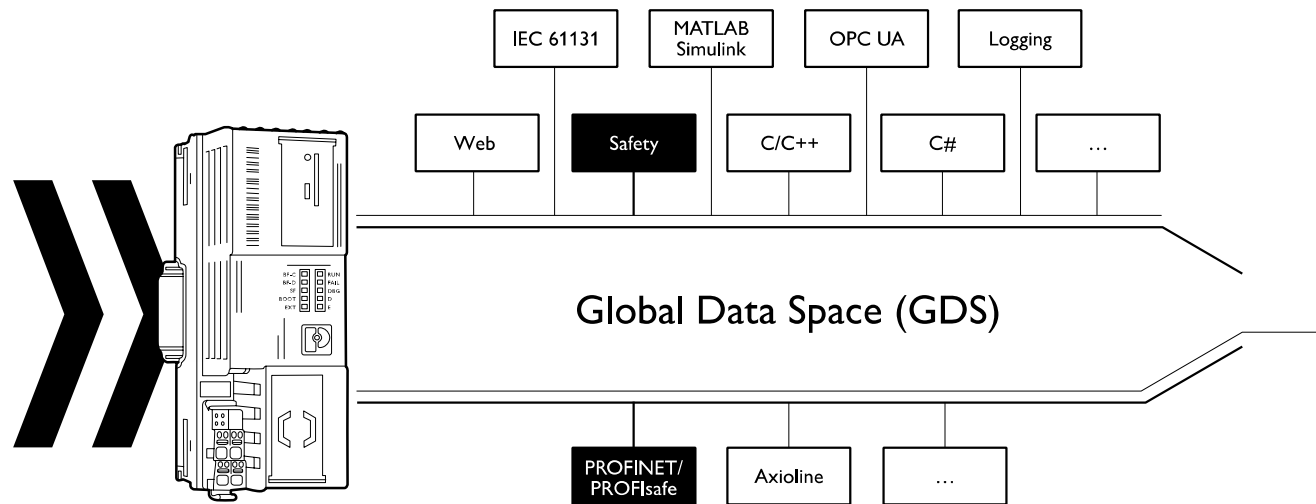

Scalable Safe PLCs

PLCnext Technology 
Designed by PHOENIX CONTACT

AXC F XT SPLC 3000 – High-Scale Modular Safe PLC

Outlook:
Mid 2021

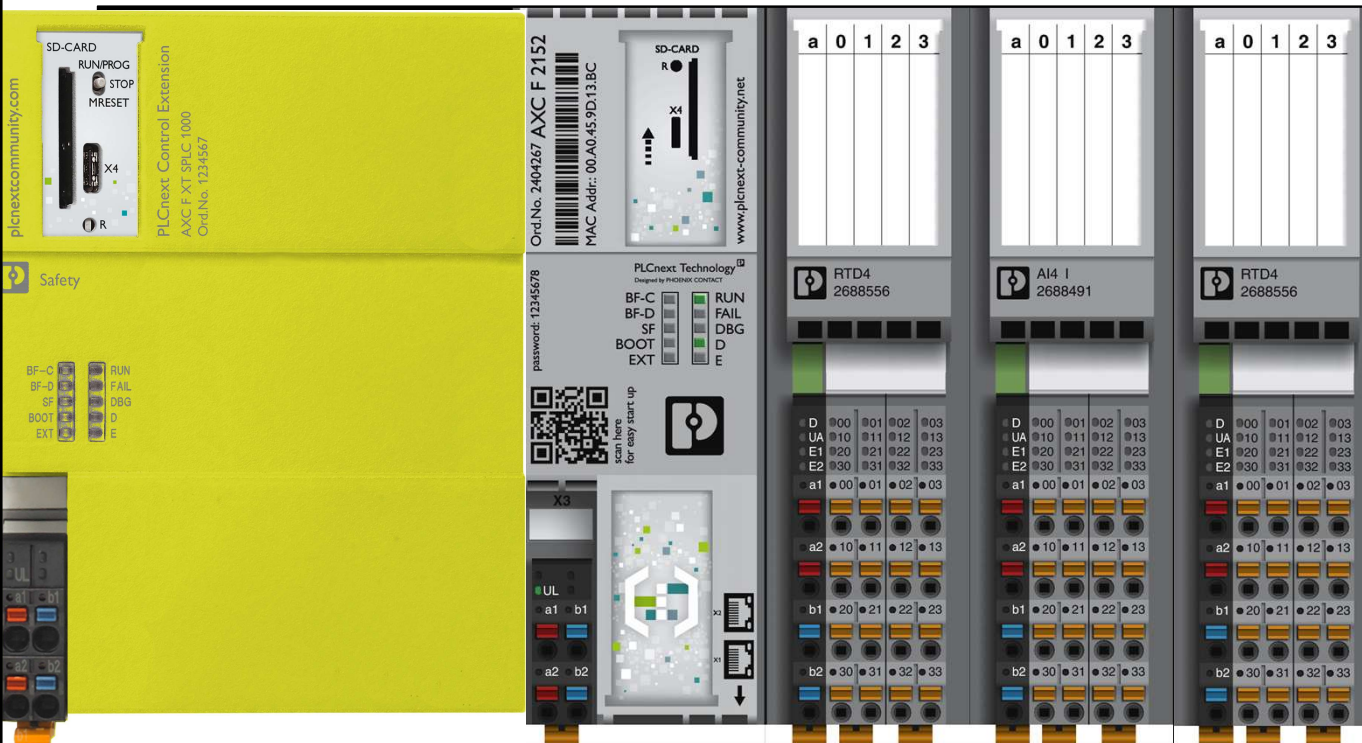

- Centralized Safe PLC
- Left-hand side connectable to PLCnext Controls
- Supported Safety Protocols:
 - PROFIsafe V2.61 (300 instances)
 - FSoE (future)
- Connectable to higher-layer SPLC
 - as PROFIsafe Slave
 - via new OPC UA Safety Protocol

Scalable Safe PLCs

AXC F XT SPLC 1000 – Low-Scale Modular Safe PLC

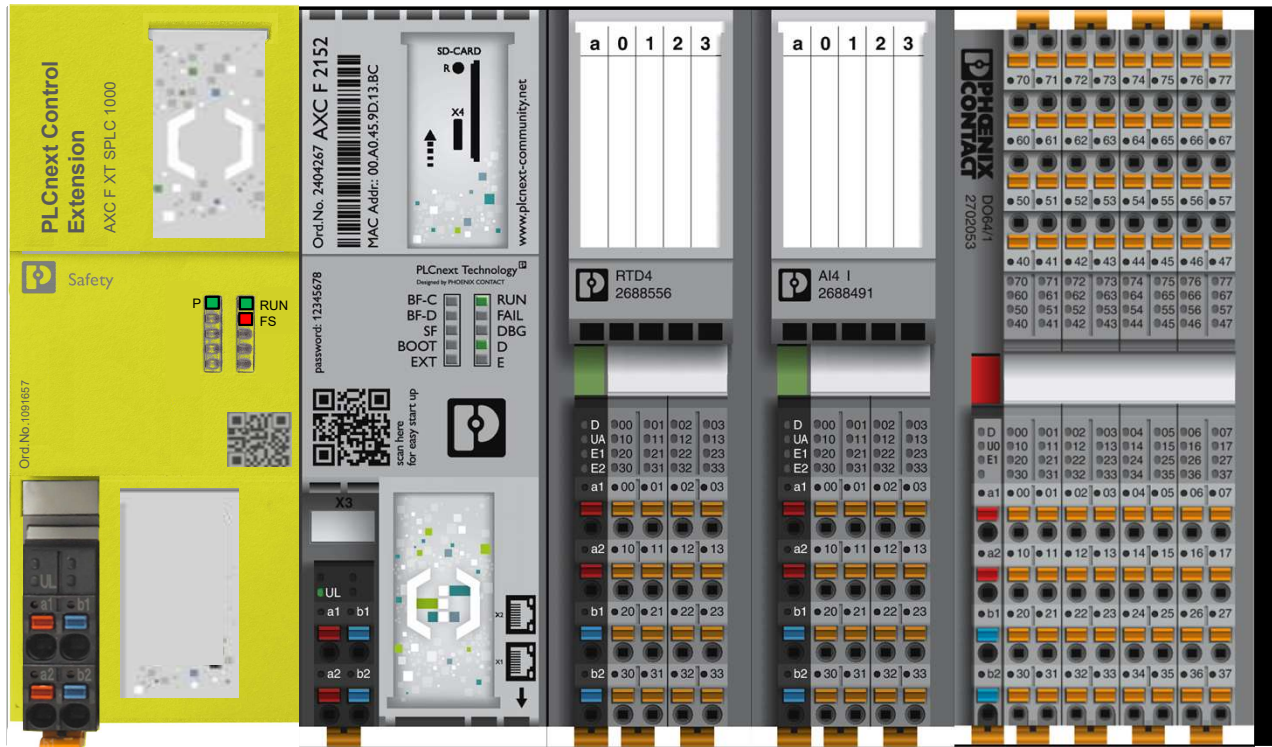

- Decentralized Small Safe PLC
- Left-hand side connectable to PLCnext Controls
- Supported Safety Protocols:
 - PROFIsafe V2.61 (32 instances)
 - FSoE (future)
- Connectable to higher-layer SPLC
 - as PROFIsafe Slave
 - via new OPC UA Safety Protocol

Scalable Safe PLCs

AXC F XT SPLC 1000 Categorization

Centralized Safe PLC

- e.g. SPLC 3000 @ AXC F 3152, alternatively RFC 480S / RFC 4072S
- Higher-layer plant control

Higher-layer network

- Step 1: PROFIsafe via PROFINET
- Step 2: Safety via OPC UA

Decentralized small-scale Safe PLC

- **AXC F XT SPLC 1000 @ AXC F 2152 (or 3152)**
- decentralized machine control incl. Safety

Machine network

- Step 1: PROFIsafe via PROFINET
- Step 2: FSoE via Ethercat

Field layer

- Step 1: PROFIsafe IO + intelligent field devices
- Step 2: FSoE IO + intelligent field devices

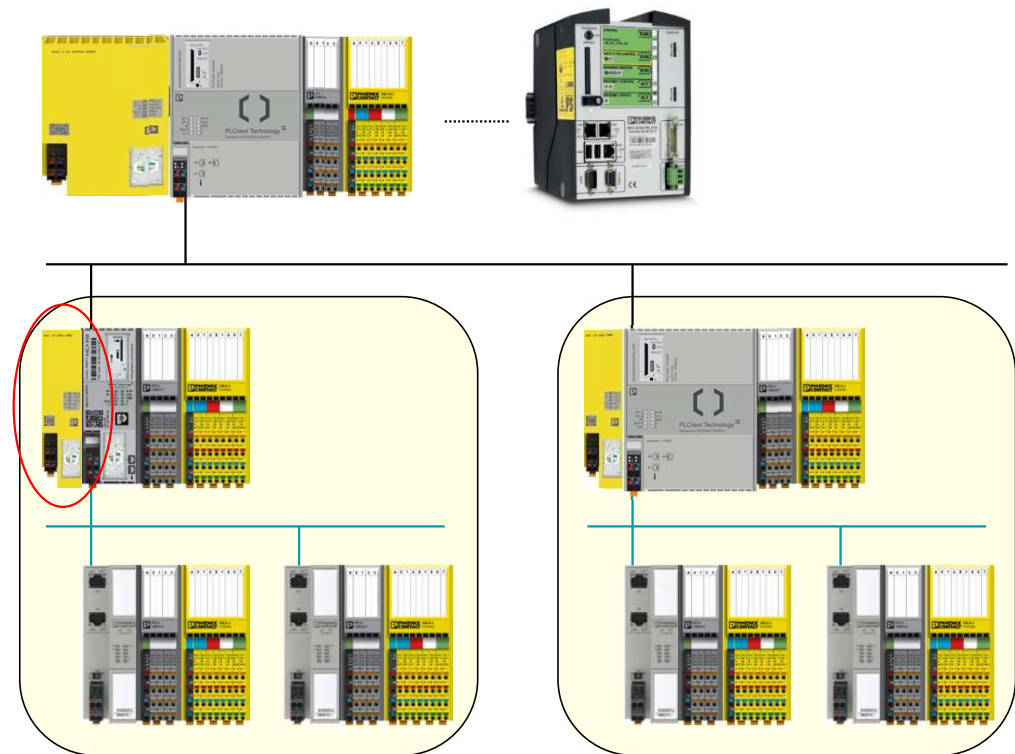

PLCnext Safety / SafetyBridge Categorization

PLCnext Safety

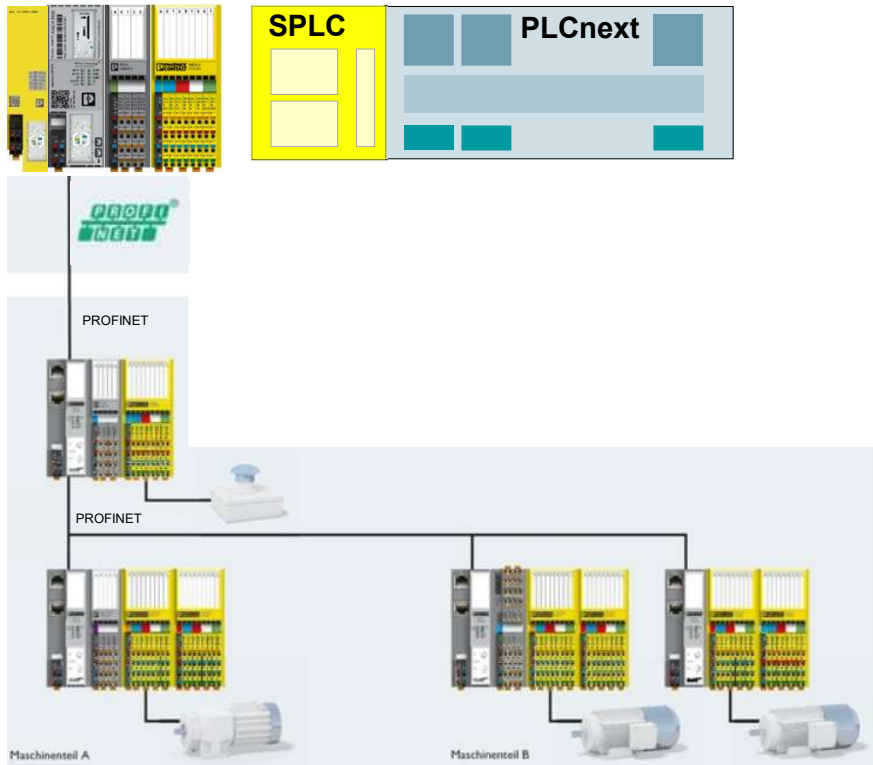

PLCnext Technology 
Designed by PHOENIX CONTACT

SafetyBridge Technology

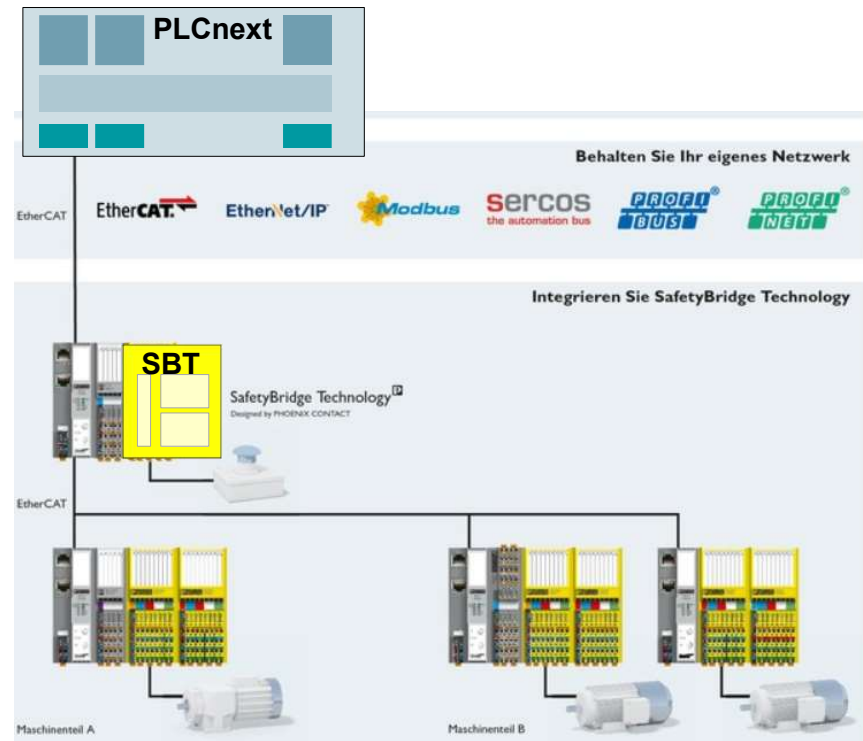



Controladores tipo Software

Advanced Training

Software PLC – General Data



FTP-Server

IEC 61131-3



Web Server



SW for IPC or Windows



Real-time clock



Software PLC - differences

	PC Worx RT Basic	PC Worx SRT
Engineering	PC Worx	PC Worx
Installation on	IPC	Windows or IPC
Performance class	High control performance and large-sized memory	Compact controller
Real-time capability	-	✓
Interbus	✓ only in conjunction with an INTERBUS master controller board	-
Program memory	8 MByte	1 MByte
Mass storage	16 MByte	1 MByte
Retentive mass storage	240 kByte	48 kByte



Controllers EcoSystem PLCnext Technology

From Vision to reality: made with PLCnext Technology → Enabling future today



PLCnext Technology[®]

Designed by PHOENIX CONTACT



PLCnext Control

Open Control Platform

Devices in various performance classes including PLCnext Runtime System and accessories



PLCnext Engineer

Engineering Software

Engineering tool for commissioning, configuring and programming PLCnext Control



PLCnext Store

Software Store

Apps for functional extension of PLCnext Control and PLCnext Engineer



PLCnext Community

Collaboration & Resources

We offer our community Information, support and helpful resources, including FAQs, forums, tutorials, and a GitHub presence

PLCnext Technology Ecosystem

PLCnext Technology

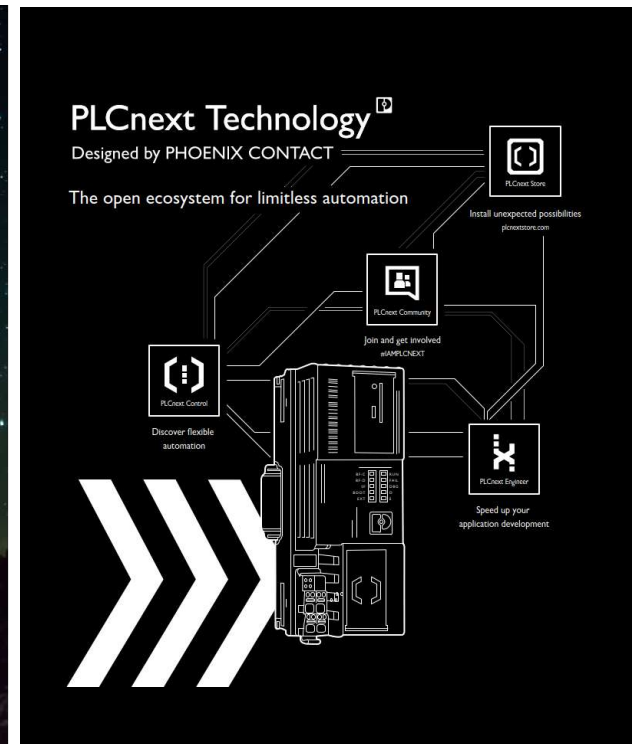
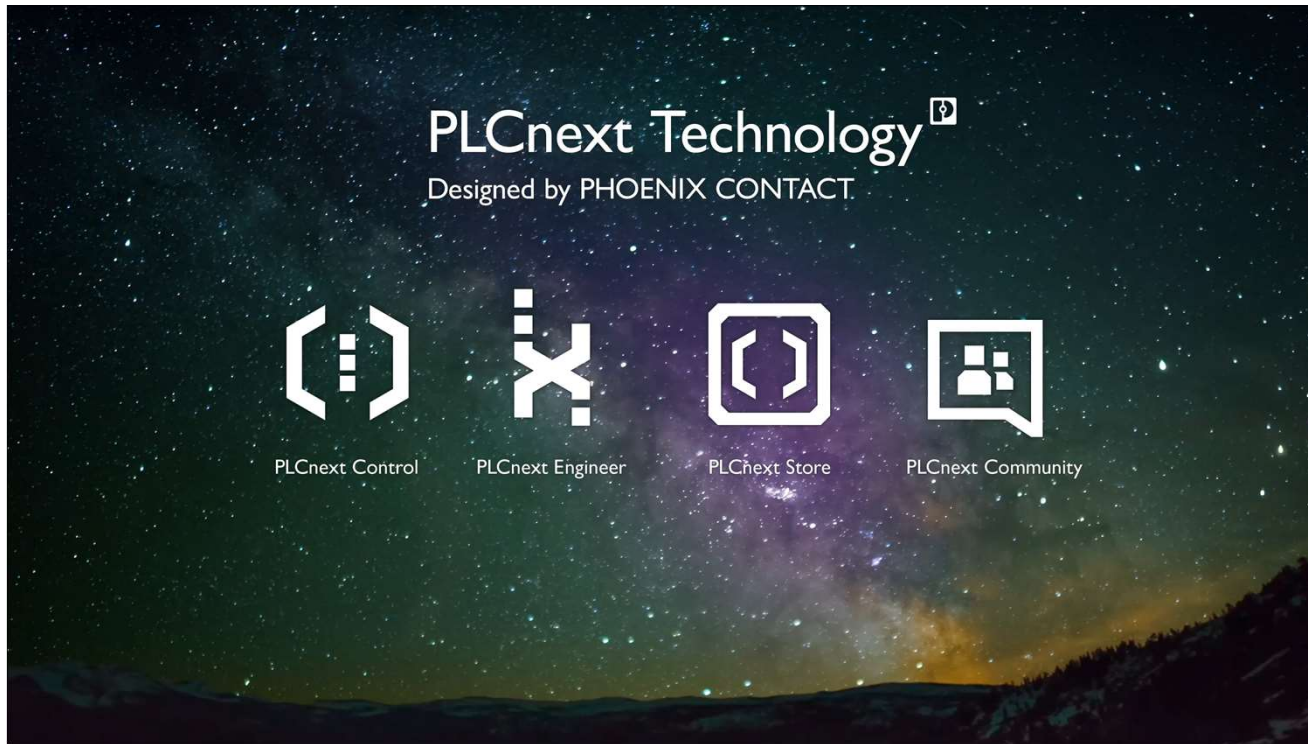

Thank you

Webinar IMA 2020

Mayor información



PHOENIX CONTACT

Phoenix Contact, S.A. de C.V.
Lago Alberto 319 Piso 9,
Locales 902 y 903-A.
Col. Granada Del. Miguel Hidalgo,
Ciudad de México. 11520
Tel.: +52 55 1101 1380 Ext. 393
Cel.: +52 55 3233 6518
agordillo@phoenixcontact.com.mx
www.phoenixcontact.com.mx

Ing. Antonio Gordillo
Infraestructure and Systems Automation
Product Marketing Manager



www.phoenixcontact.com.mx

ventas@phoenixcontact.com.mx

55 1101 1380

Actividades 2020

Folletos

Presentaciones

Webinars